



DRAWINGS

Rampes mobiles
Rampes fixes
Plateformes logistiques
Rampes de quai
Réhausse
Tables de quai mobiles
Tables de quai fixes
Passerelles
Rampes pour conteneurs
Niveleurs
Fournitures de quai



DRAWINGS

Rampes mobiles

Rampes fixes

Plateformes logistiques

Rampes de quai

Réhausse

Tables de quai mobiles

Tables de quai fixes

Passerelles

Rampes pour conteneurs

Niveleurs

Fournitures de quai

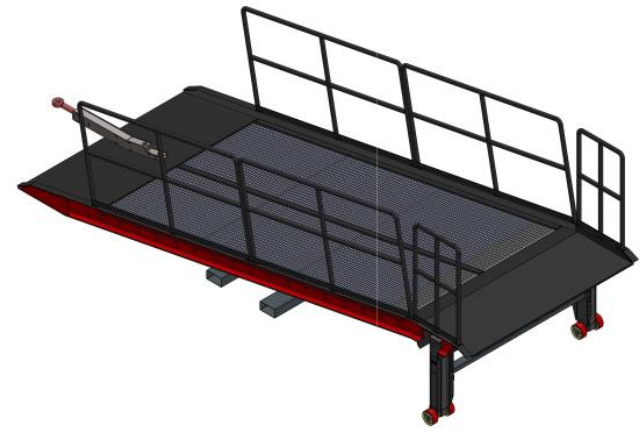
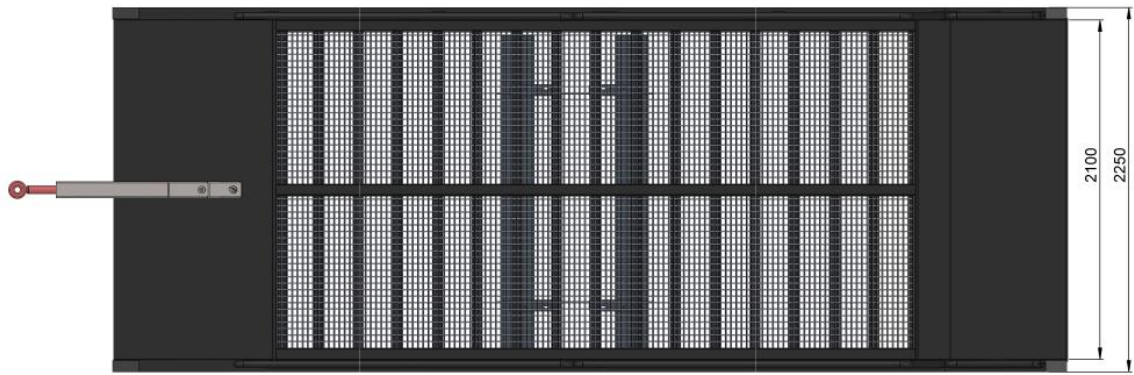
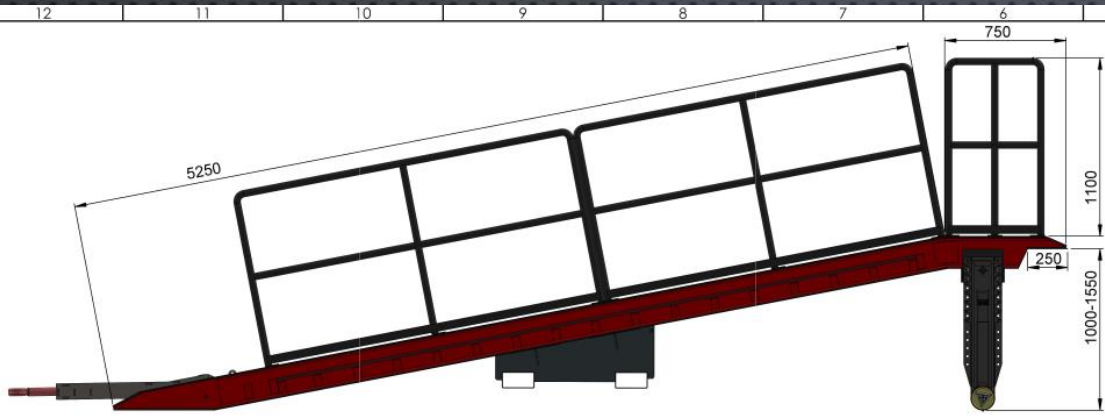

NAME - SURNAME	DATE	SIGN	QUANTITY	MASS (KG)	MATERIAL	PAGE NR
---	---	---	---	---	---	1/1
CONTROL	---	---	---	---	---	---
APPROVAL	---	---	---	---	---	---
SCALE	1:50	---	---	---	---	---
PART/ASSEMBLY NAME			DRAWING DESCRIPTION		DRAWING NO.	
---			---		---	



AZ MACHINERY - SLU, Matériels d'Élévation et Maintenance
 13 rue de la machine - 86 540 PALAIS DE CERBACROIX - France
 Téléphone : +33 (0) 27 48 300 - contact@az-machinery.com - www.az-machinery.com
 Site : 824 654 958 606 19 - TVA : FR02 824 654 958 - N° ED081 - FR03 824 654 958

PRIME WLO 8 TON

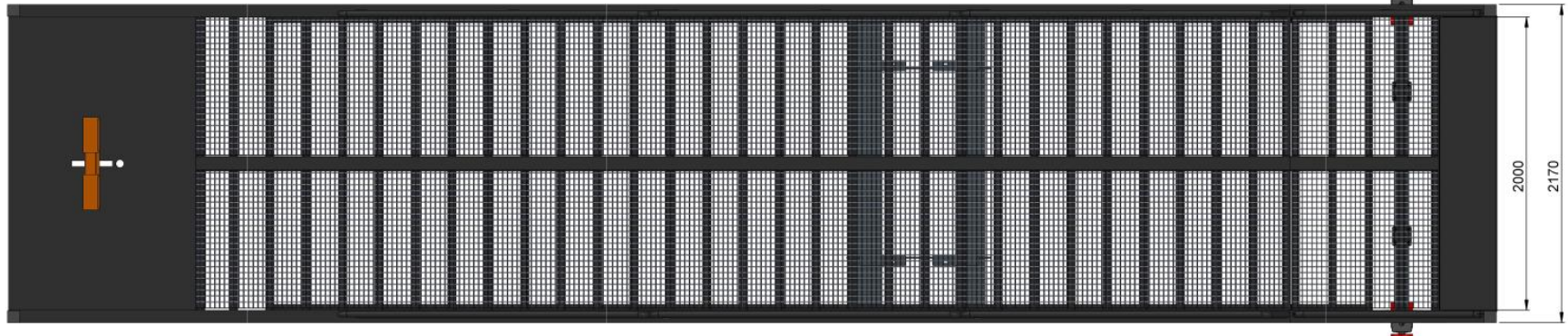
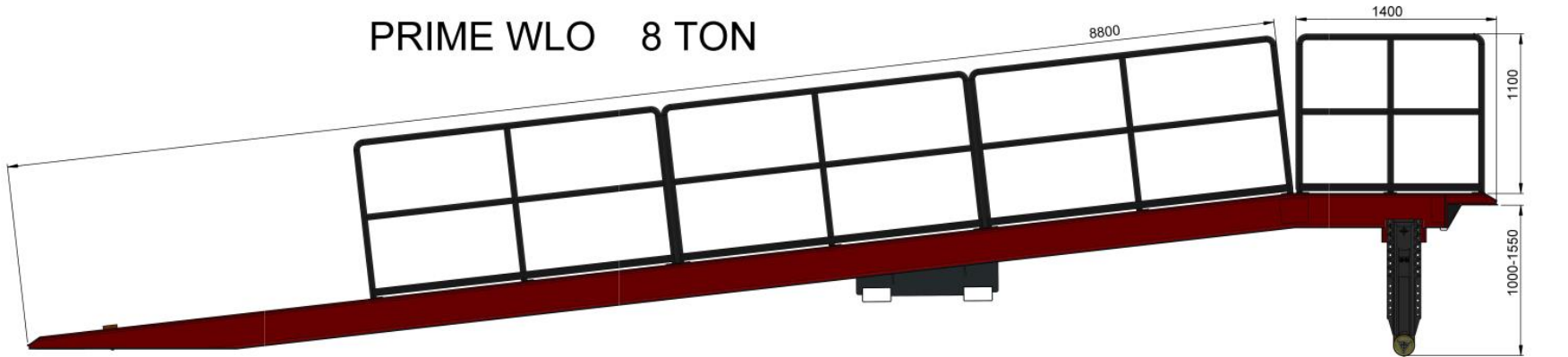

NAME - SURNAME	DATE	SIGN	QUANTITY	MASS (KG)	MATERIAL	PAGE NR
---	---	---	---	---	---	1/1
CONTROL	---	---	---	---	---	---
APPROVAL	---	---	---	---	---	---
SCALE	1:50	---	---	---	---	---
PART/ASSEMBLY NAME			DRAWING DESCRIPTION		DRAWING NO.	
---			---		---	

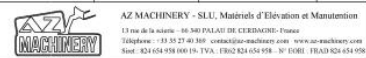

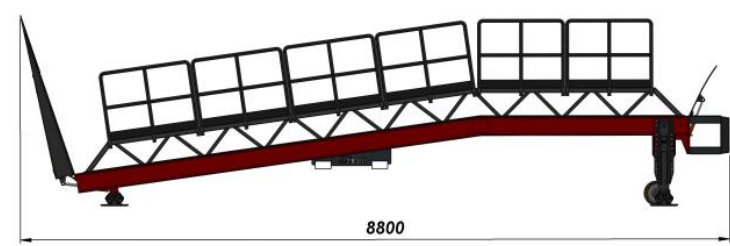
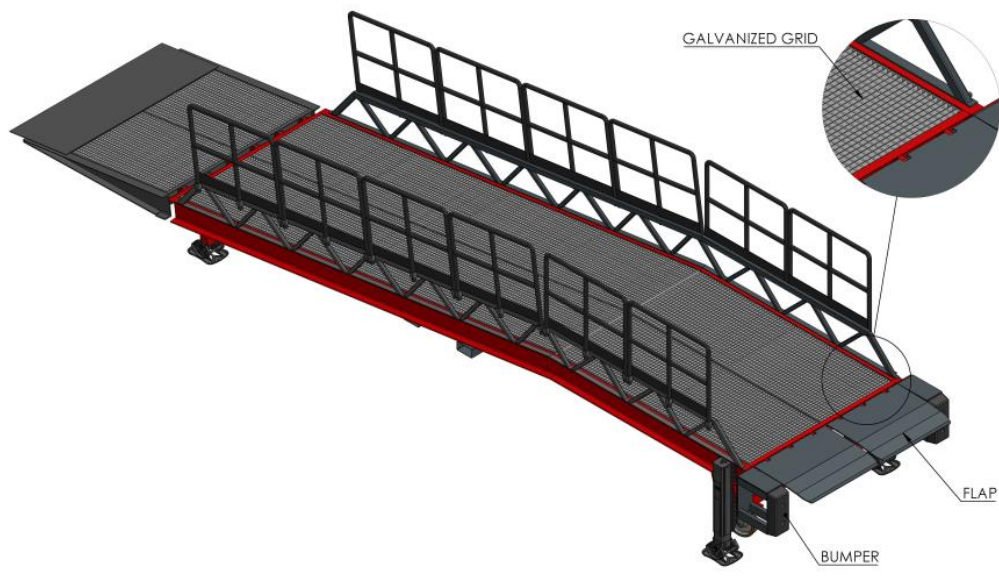
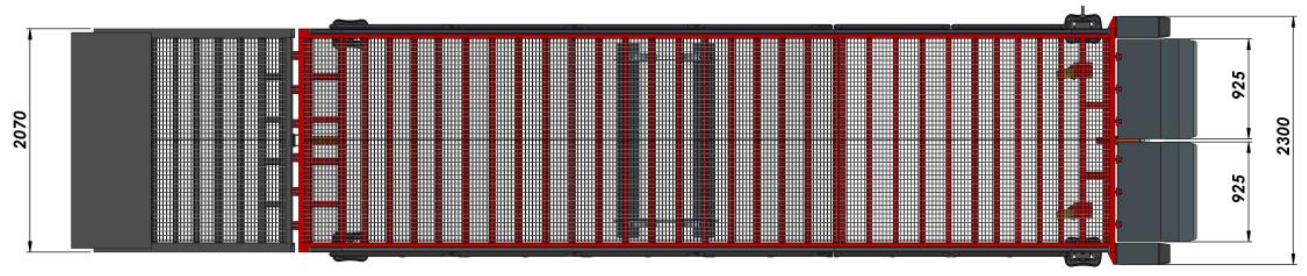
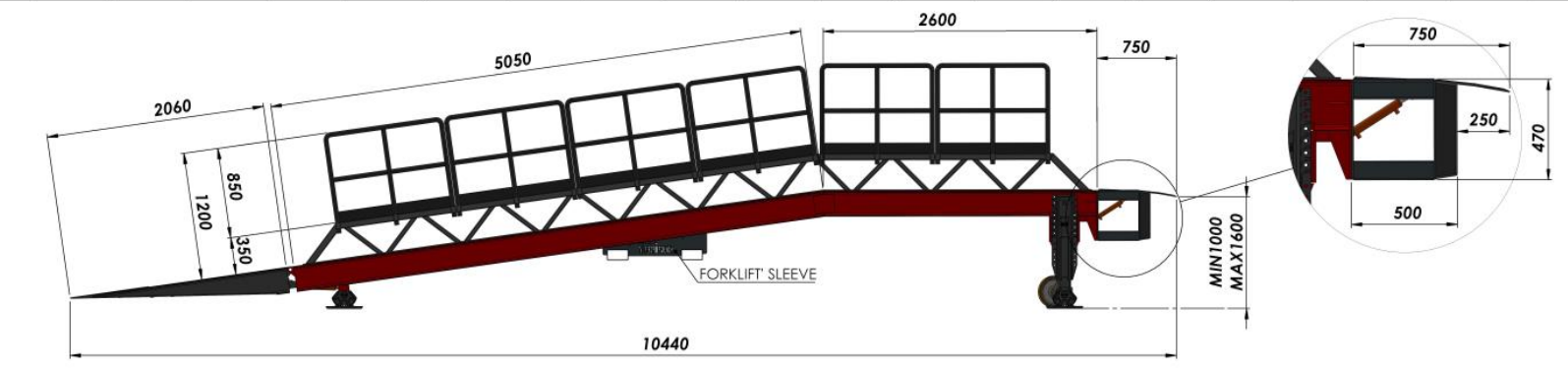

NAME - SURNAME	DATE	SIGN	QUANTITY	MASS (KG)	MATERIAL	PAGE/NI
DRAWN BY: H. CANSEVER	11.01.2022		---			1/1
CONTROL: A. HEPBILDI	11.01.2022					
APPROVAL: S. ENTZMANN	11.01.2022					
SCALE: 1:50						
PART/ASSEMBLY NAME	DRAWING DESCRIPTION:		DRAWING NO.			
	STAR STANDART (8-10-12 TONS)+ 120 CM GUARDRAIL + REFUGE ZONE + FORKLIFT S SLEEVE		---			5

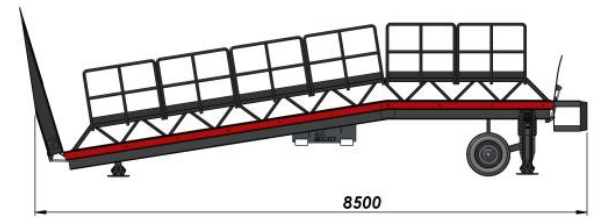
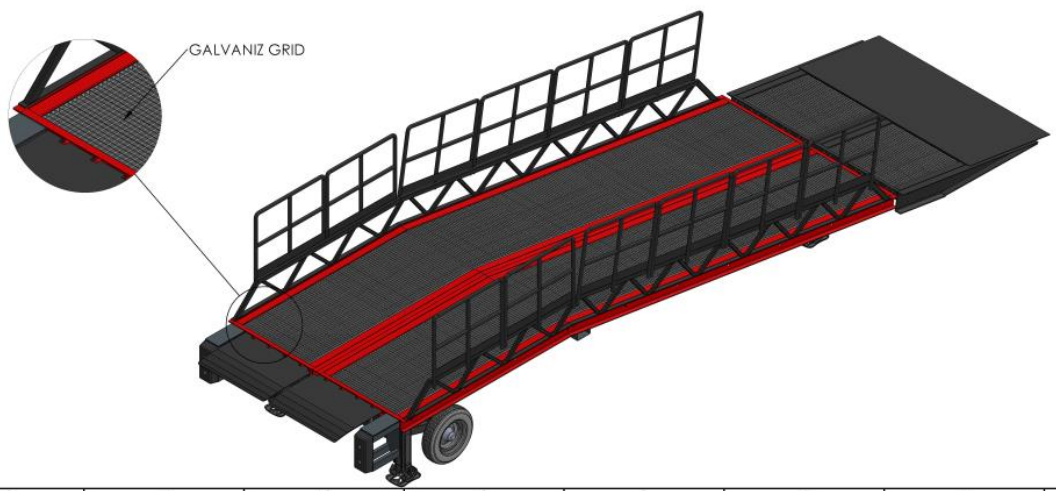
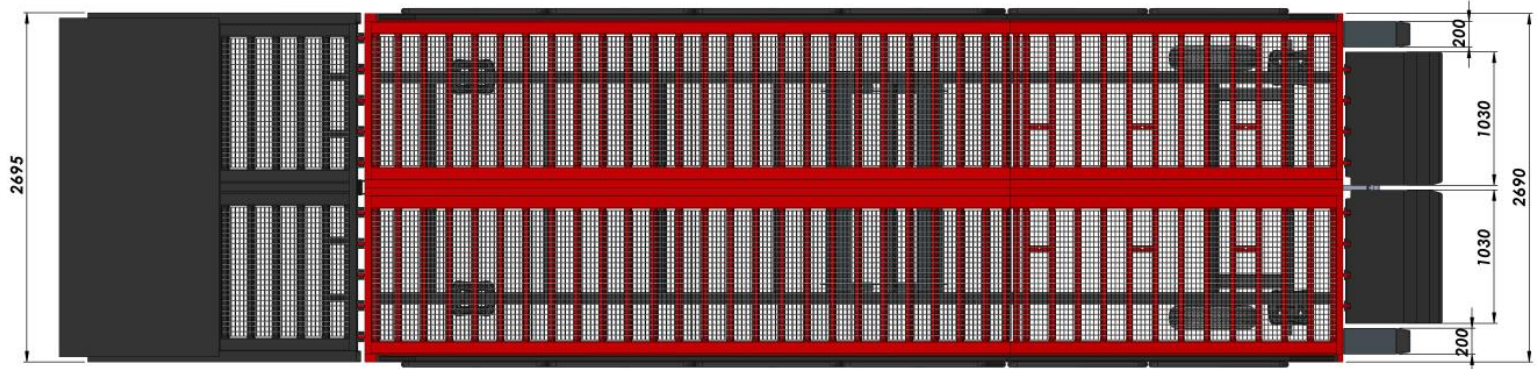
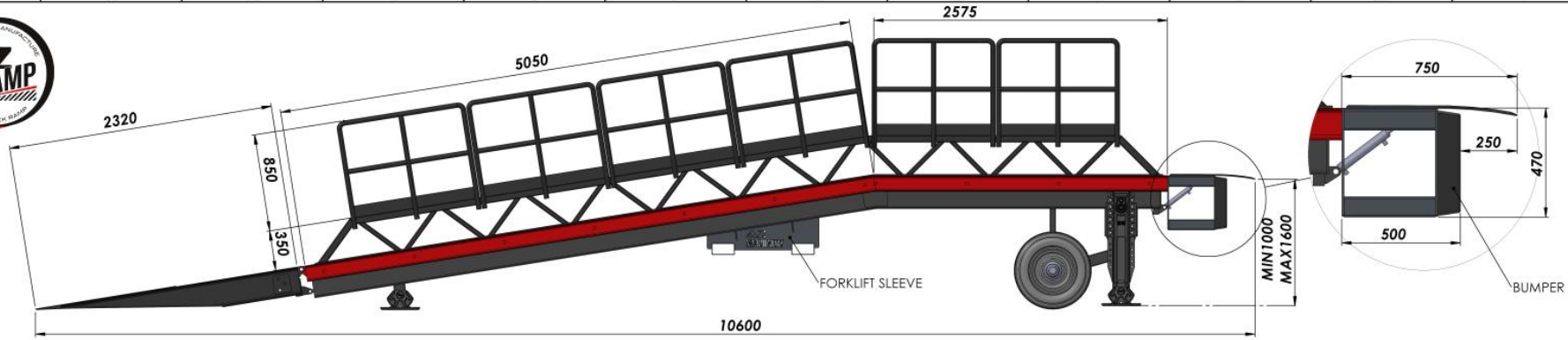

NAME - SURNAME	DATE	SIGN	QUANTITY	MASS (KG)	MATERIAL	PAGE NR
DRAWN BY: H. CANSEVER	04.02.2022		---			1/1
CONTROL: A. HEPBILDI	04.02.2022					
APPROVAL: S. ENTZMANN	04.02.2022					
SCALE: 1:100						
PARTS/ASSEMBLY NAME			DRAWING DESCRIPTION:		DRAWING NO.	
			STAR-KING-S (8-10-12 TONS)		---	

AZ MACHINERY
 AZ MACHINERY - SLU, Matériels d'Élévation et Manutention
 13 rue de la scierie - 05 340 PÉLASSI DE CÉREACRENS - France
 Téléphone : +33 47 27 46 100 - contact@az-machinery.com - www.az-machinery.com
 Site : 024 654 958 000 10 - TVA : FR02 824 654 958 - N° EORI : FR02 824 654 958

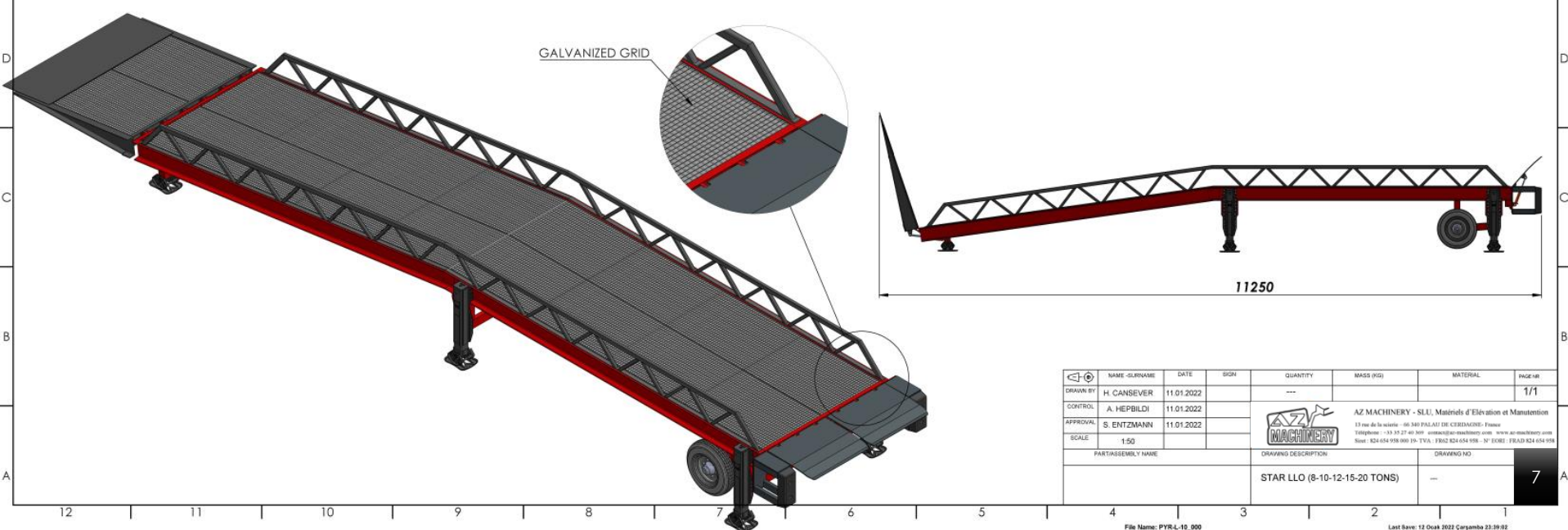
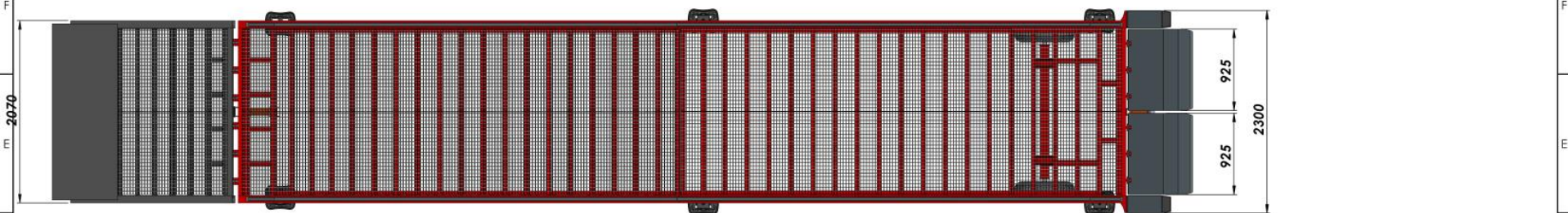
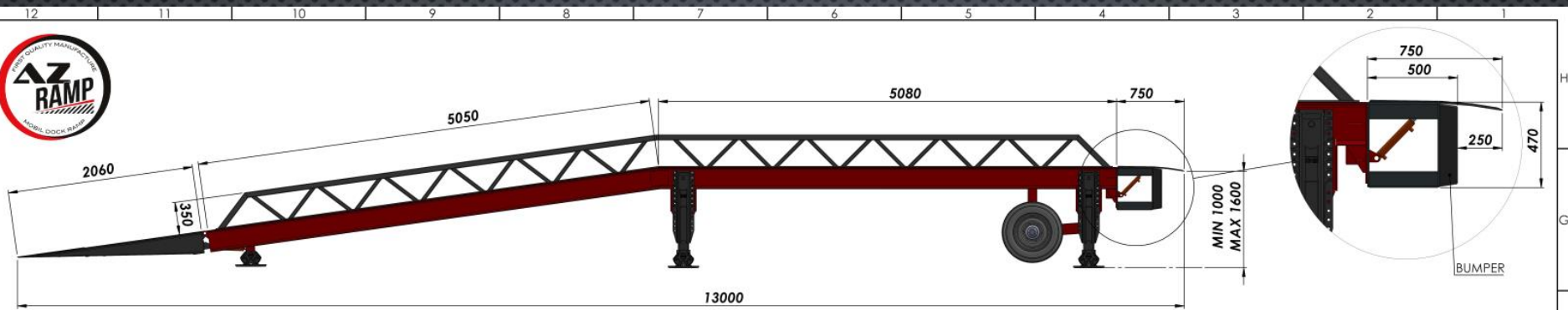

NAME - SURNAME	DATE	SIGN	QUANTITY	MASS (KG)	MATERIAL	PAGE NR
DRAWN BY: H. CANSEVER	11.01.2022		---			1/1
CONTROL: A. HEPBILDI	11.01.2022					
APPROVAL: S. ENTZMANN	11.01.2022					
SCALE: 1:50						
PART/ASSEMBLY NAME			DRAWING DESCRIPTION		DRAWING NO.	
			STAR LLO (8-10-12-15-20 TONS)		---	

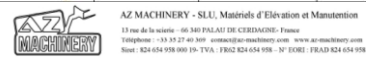

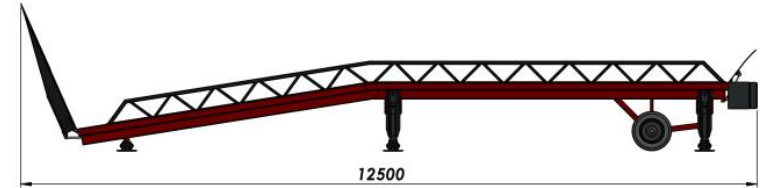
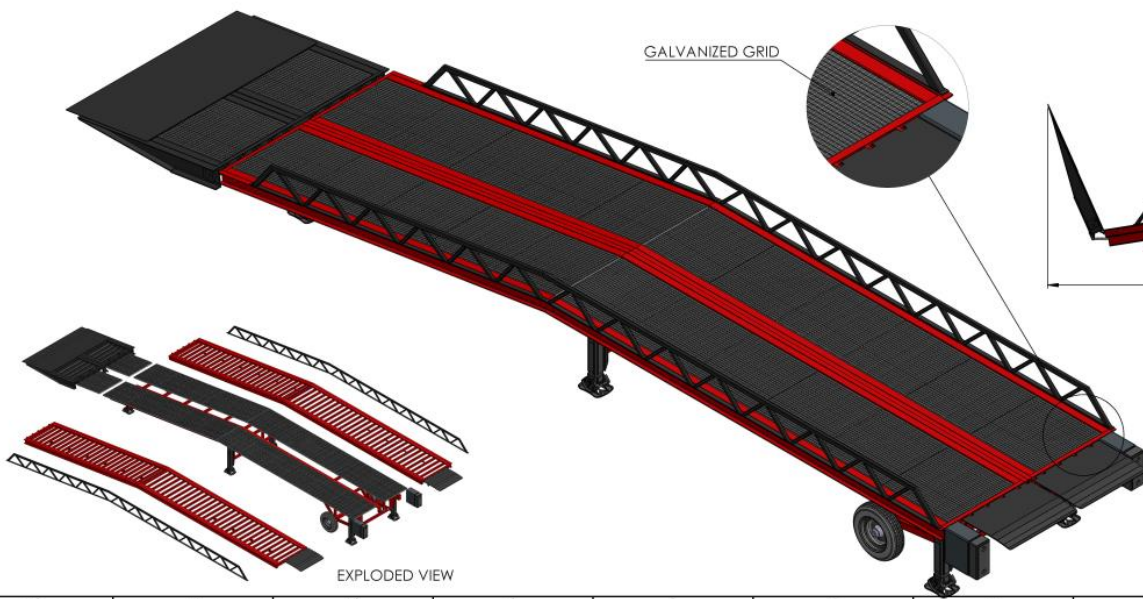
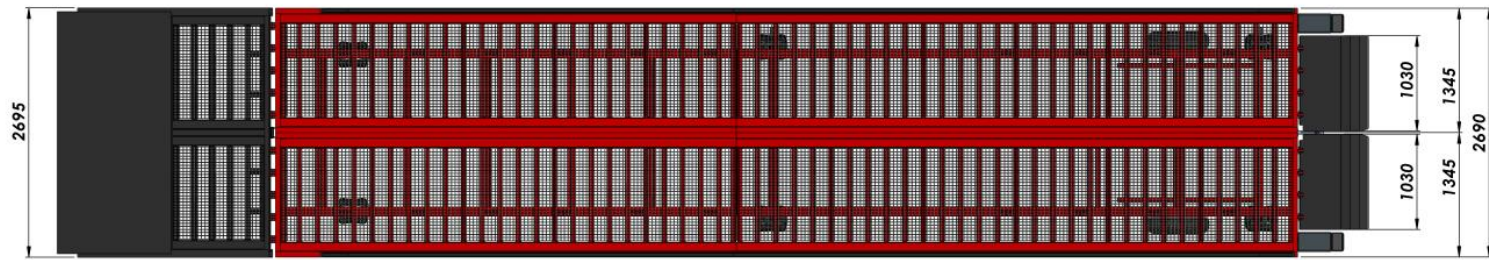
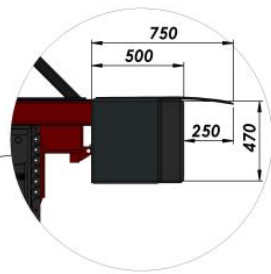
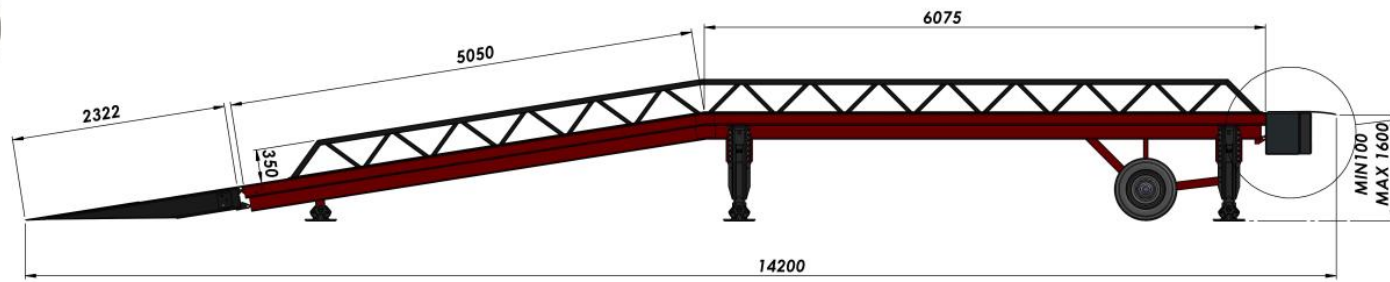

NAME - SURNAME	DATE	SIGN	QUANTITY	MASS (KG)	MATERIAL	PAGE (NR)
DRAWN BY: H. CANSEVER	11.01.2022		---			1/1
CONTROL: A. HEPBILDI	11.01.2022					
APPROVAL: S. ENTZMANN	11.01.2022					
SCALE: 1:100						
PART/ASSEMBLY NAME	DRAWING DESCRIPTION:			DRAWING NO.		
	STAR-XL (8-10-12-15-20 TONS)			---		



AZ MACHINERY - SLU, Matériels d'Élévation et Maintenance
 13 rue de la scierie - 06340 PALAISEAU DE CERDASNIEN - France
 Téléphone : +33 (0) 27 48 3007 - contact@az-machinery.com - www.az-machinery.com
 Site : 024 654 958 000 19 - TVA : FR02 824 654 958 - N° EORI : FR02 824 654 958

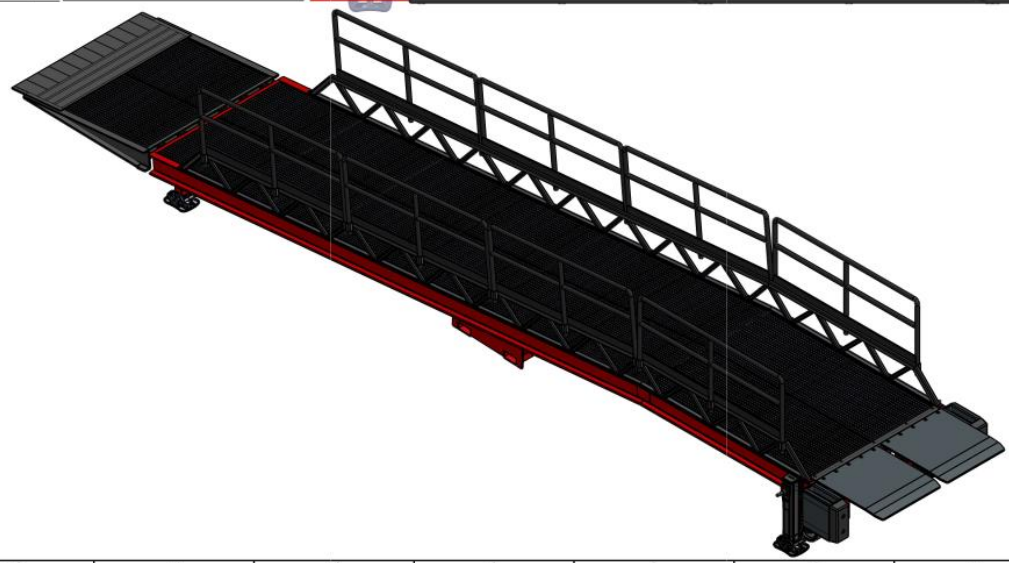
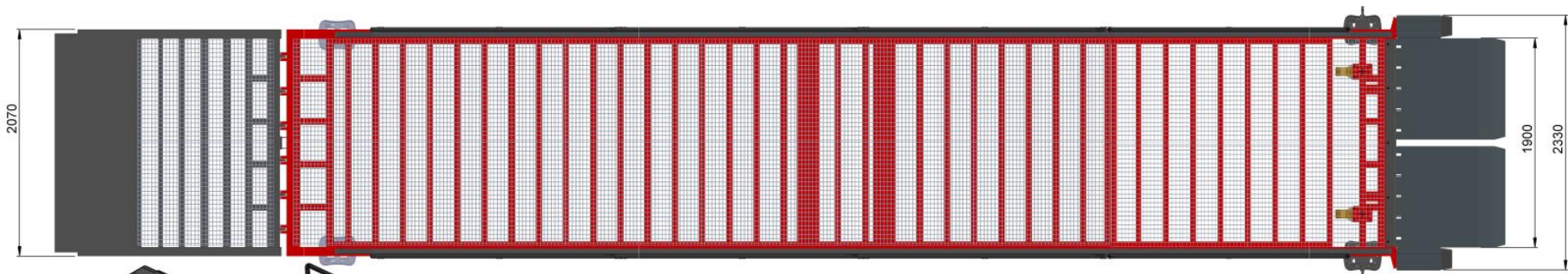
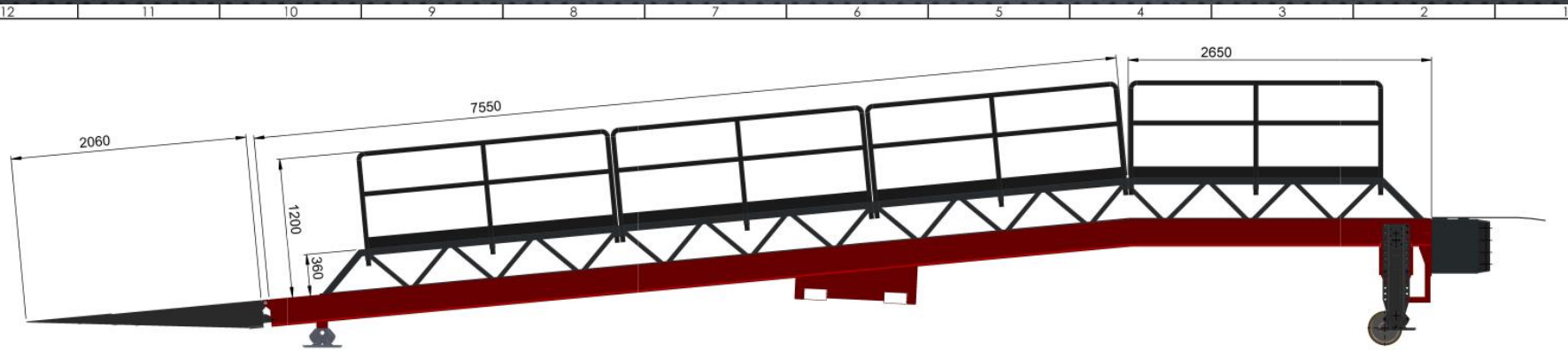

NAME - SURNAME	DATE	SIGN	QUANTITY	MASS (KG)	MATERIAL	PAGE (NR)
---	---	---	---	---	---	1/1
CONTROL	---	---	---	---	---	---
APPROVAL	---	---	---	---	---	---
SCALE	1:50	---	---	---	---	---
PART/ASSEMBLY NAME			DRAWING DESCRIPTION		DRAWING NO.	
			#79US ---		---	



AZ MACHINERY - SLU, Matériels d'Élévation et Maintenance
 13 rue de la société - 05 340 PÉLASSI DE CERDANNE - France
 Téléphone : +33 37 27 46 100 - contact@az-machinery.com - www.az-machinery.com
 Site : 024 654 958 000 19 - TVA : FR02 824 654 958 - N° EORI : FR02 824 654 958

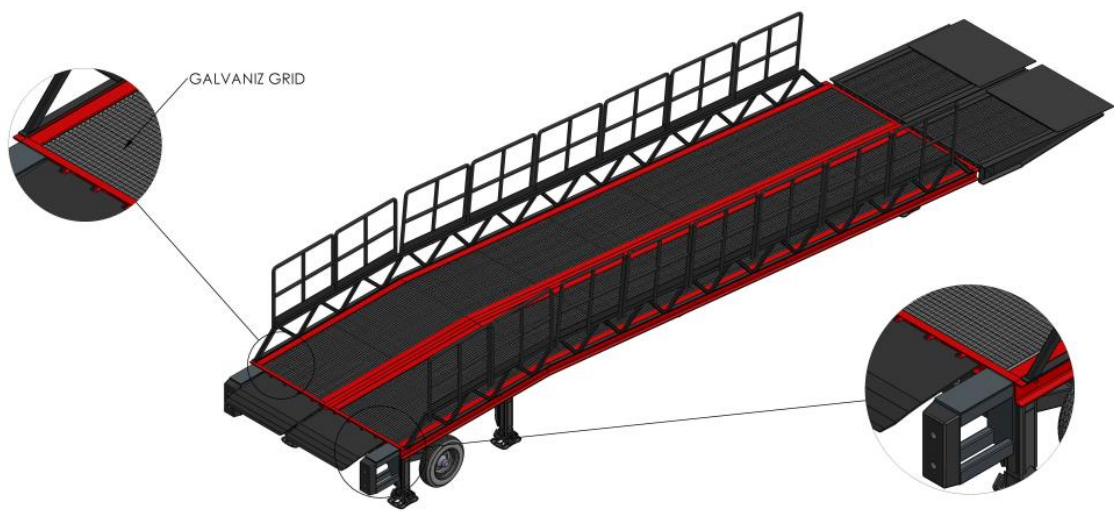
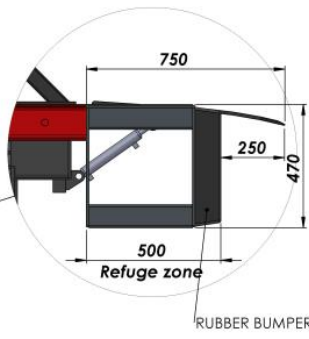
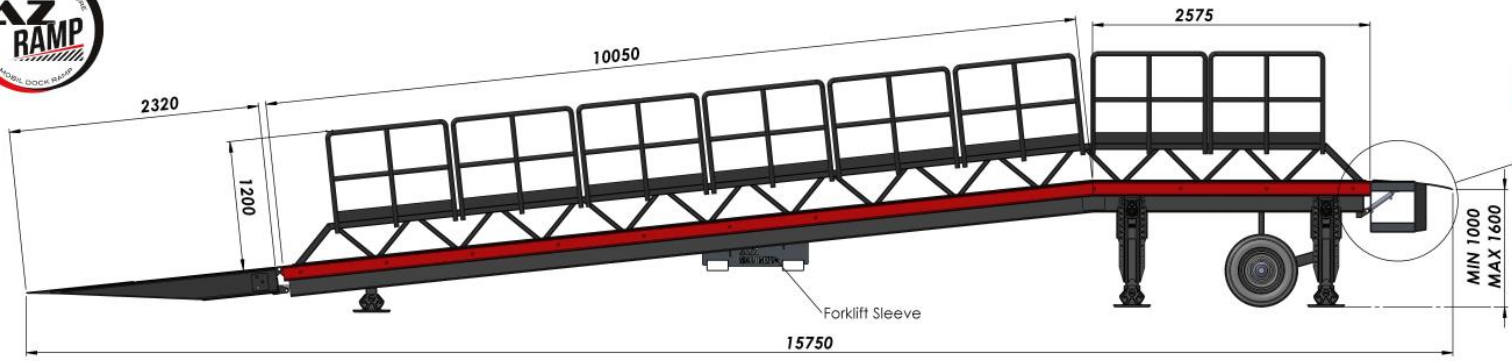

CAPACITY: 13000 KG

NAME - SURNAME	DATE	SIGN	QUANTITY	MASS (KG)	MATERIAL	PAGE-NR
DRAWN BY: H. CANSEVER	01.07.2022		---			1/1
CONTROL: A. HEPBILDI	01.07.2022					
APPROVAL: S. ENTZMANN	01.07.2022					
SCALE: 1:100						
PARTS/ASSEMBLY NAME		DRAWING DESCRIPTION:		DRAWING NO.		
		#TSMG		---		

AZ MACHINERY - SLU, Matériels d'Élévation et Manutention
 13 rue de la scierie - 66340 PALAISEAU DE CERDANNES - France
 Téléphone : +33 47 37 46 100 - contact@az-machinery.com - www.az-machinery.com
 Site : S24 654 958 000 FR - TVA : FR02 824 654 958 - N° EORI : FR02 824 654 958

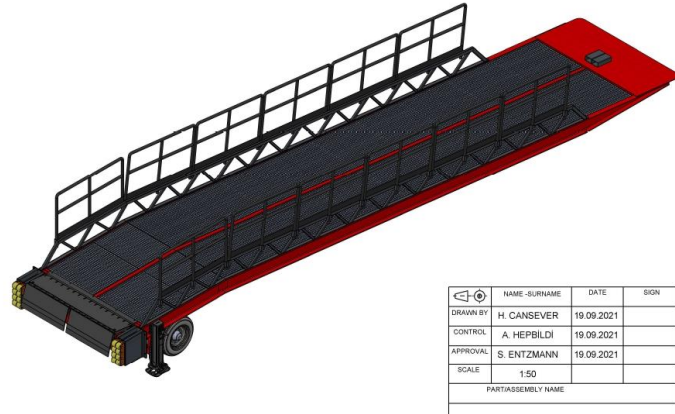
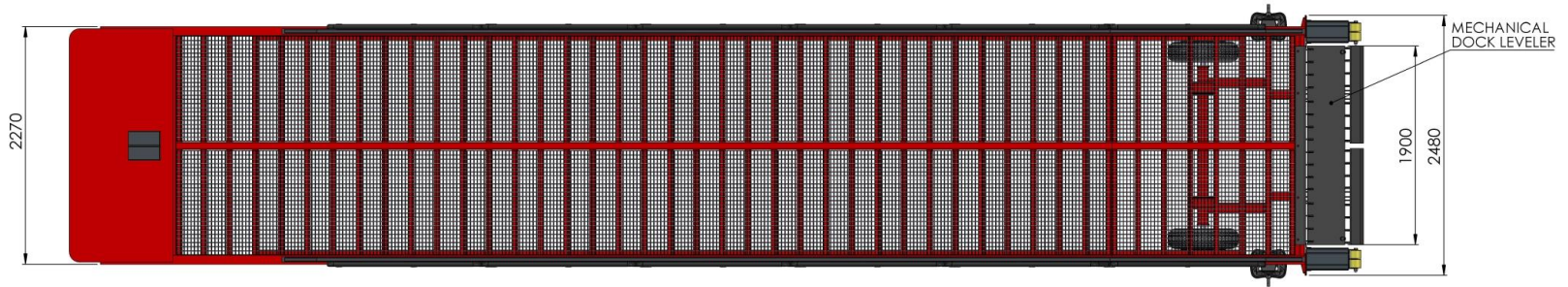
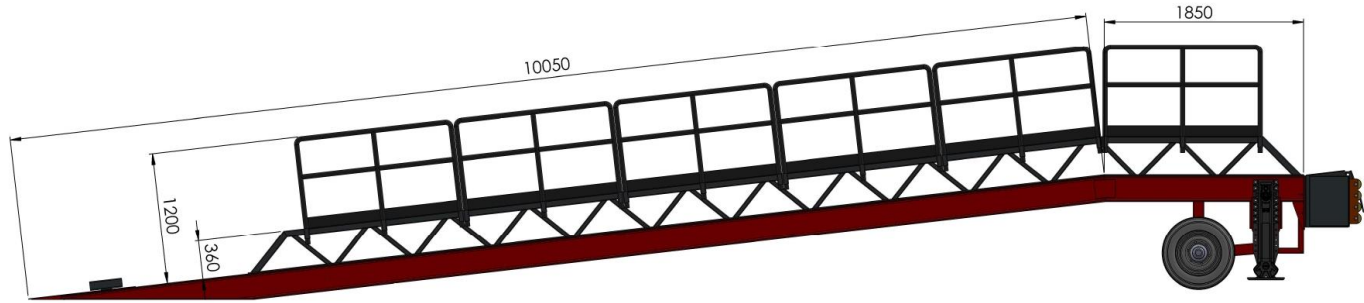

NAME-SURNAME	DATE	SIGN	QUANTITY	MASS (KG)	MATERIAL	PAGE NR
DRAWN BY: H. CANSEVER	19.09.2021		---			1/1
CONTROL: A. HEPBILDI	19.09.2021					
APPROVAL: S. ENTZMANN	19.09.2021					
SCALE: 1:50						
PARTASSEMBLY NAME	DRAWING DESCRIPTION		DRAWING NO			
	EASY-T-XL-OTC		---			



AZ MACHINERY - SLU, Matériels d'Élévation et Manutention
 13 rue de la scierie - 06340 PALAISEAU DE CERDAGNE - France
 Téléphone : +33 (0) 47 48 500 - contact@az-machinery.com - www.az-machinery.com
 Site : 824 654 958 000 19 - TVA : FR02 824 654 958 - N° EORI : FRAD 824 654 958

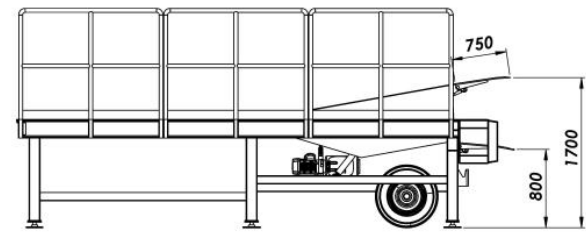
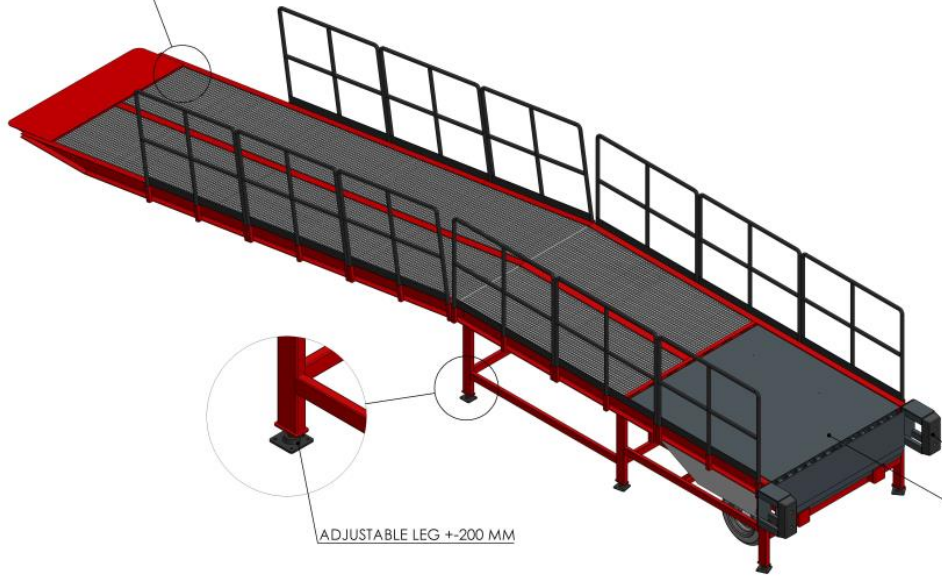
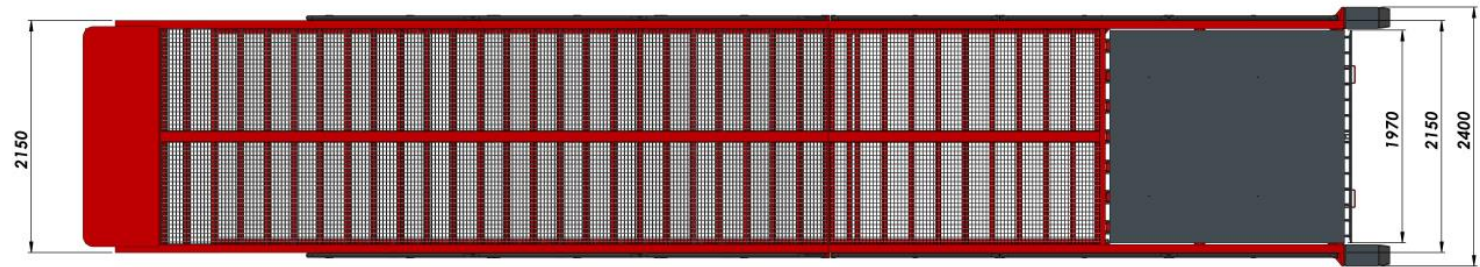
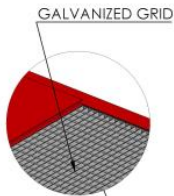
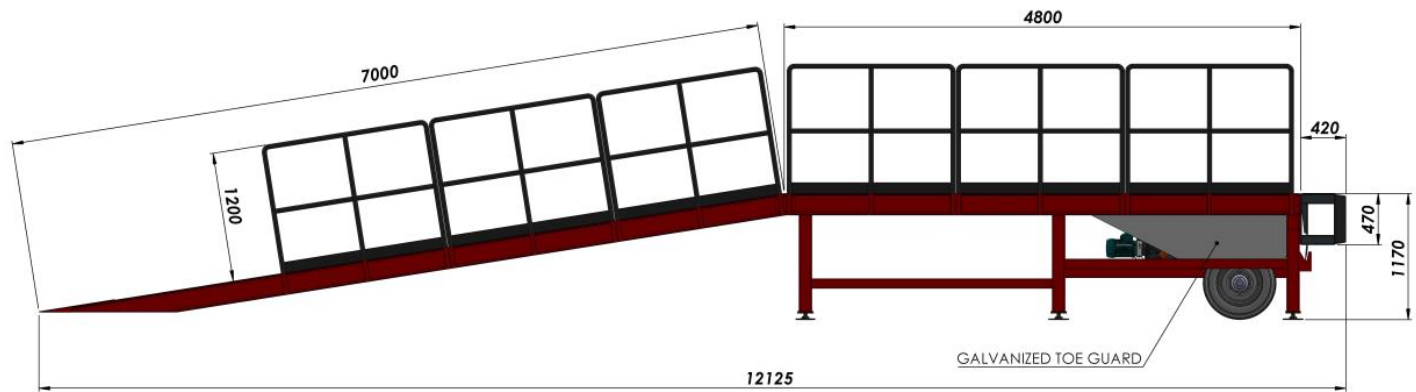

NAME - SURNAME	DATE	SIGN	QUANTITY	MASS (KG)	MATERIAL	PAGE NR
DRAWN BY: H. CANSEVER	11.01.2022		---			1/1
CONTROL: A. HEPBILDI	11.01.2022					
APPROVAL: S. ENTZMANN	11.01.2022					
SCALE: 1:50						
PARTS/ASSEMBLY NAME			DRAWING DESCRIPTION:		DRAWING NO.	
			FORMATION 2020 MOBILE		---	



AZ MACHINERY - SLU, Matériels d'Élévation et Manutention
 13 rue de la scierie - 06 540 PÉLASSI DE CERDAGNÈRE - France
 Téléphone: +33 (0) 27 46 1001 - contact@az-machinery.com - www.az-machinery.com
 Site: S24 654 958 000 TVA - TVA: FR02 824 654 958 - N° EORI: FR02 824 654 958

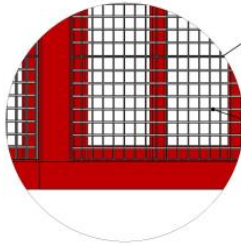
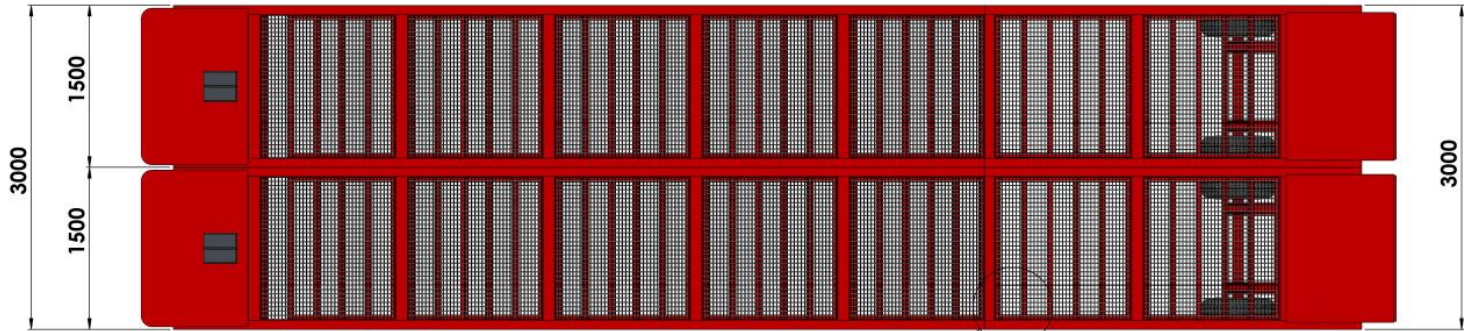
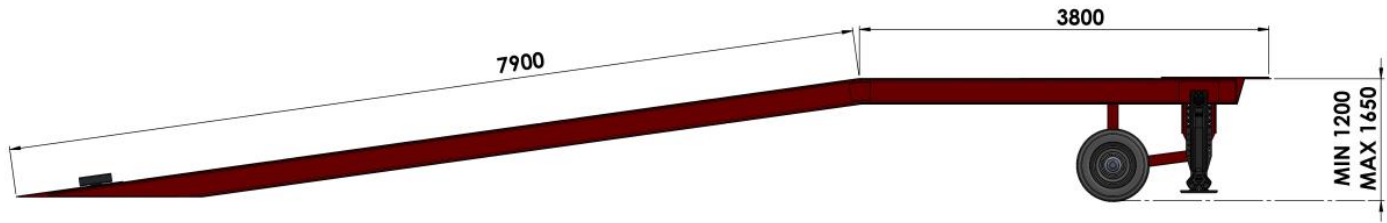

GALVANIZED GRID

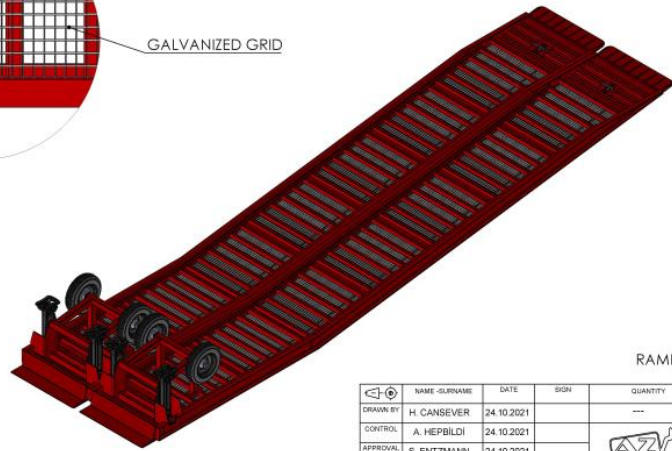
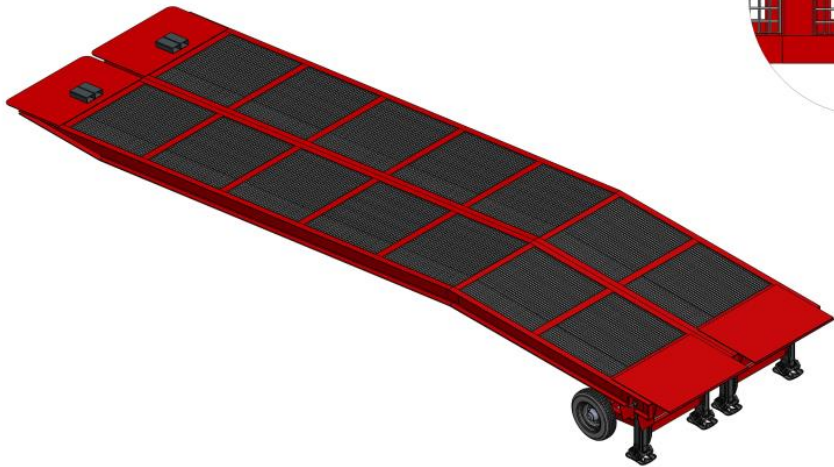

RAMP HAVE FOUR LEGS AND FOUR WHEELS

NAME - SURNAME	DATE	SIGN	QUANTITY	MASS (KG)	MATERIAL	PAGE/NO
DRAWN BY: H. CANSEVER	24.10.2021		---			1/1
CONTROL: A. HEPBILDI	24.10.2021					
APPROVAL: S. ENTZMANN	24.10.2021					
SCALE: 1:50						
PARTS/ASSEMBLY NAME	DRAWING DESCRIPTION:			DRAWING NO.		
	AZ BIG KING FOOT 20 TONS			--- #688B		

AZ MACHINERY - SLU, Matériels d'Élévation et Maintenance
 13 rue de la source - 66360 PLAILLET DE CERDANNE - France
 Téléphone : +33 (0) 37 48 500 - contact@az-machinery.com - www.az-machinery.com
 Site : 424 654 958 (6611) - TVA : FR02 824 654 958 - N° EORI : FR02 824 654 958



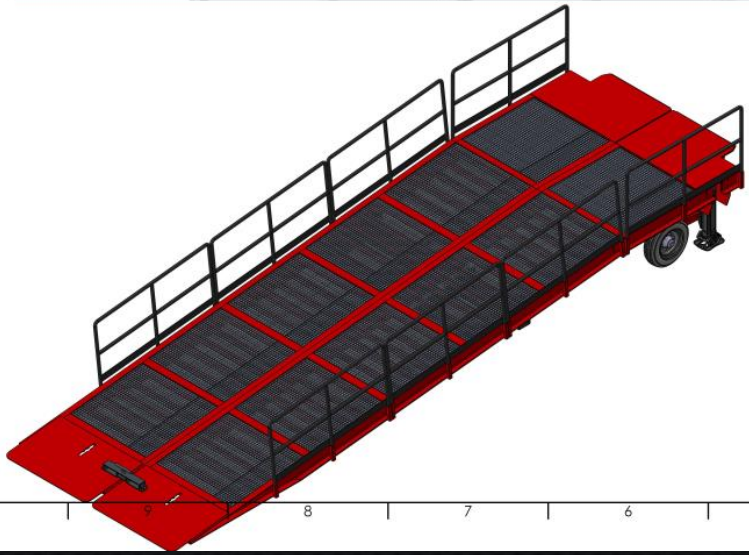
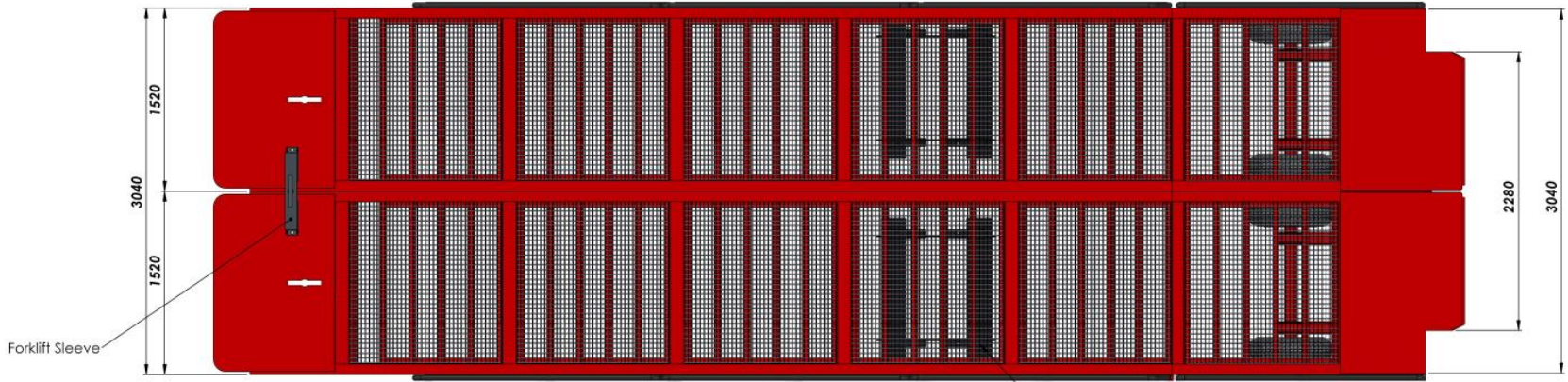
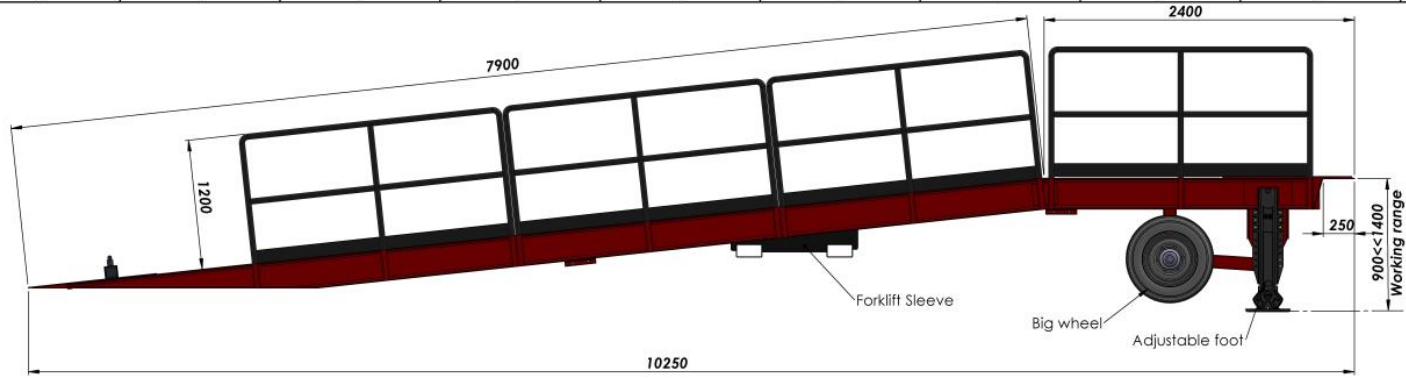

NAME-SURNAME	DATE	SIGN	QUANTITY	MASS (KG)	MATERIAL	PAGE/NT
DRAWN BY: H. CANSEVER	28.01.2023		---			1/2
CONTROL: A. HEPBILDI	28.01.2023					
APPROVAL: S. ENTZMANN	28.01.2023					
SCALE: 1:50						
PARTASSEMBLY NAME	DRAWING DESCRIPTION:			DRAWING NO.		
	BIG FOOT RAMP			--- #688B		



AZ MACHINERY - SLU, Matériels d'Élévation et Manutention
 13 rue de la scierie - 36300 PALLATI DE CERBACHIN - France
 Téléphone : 03 35 27 48 500 - contact@az-machinery.com - www.az-machinery.com
 Site : 03 654 958 606 FR - TVA : FR02 824 654 958 - 3° ED080 - FR03 824 654 958

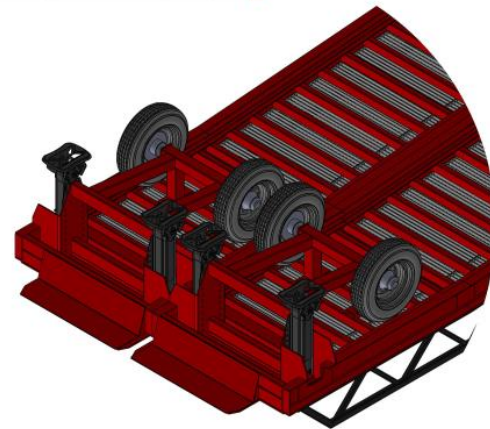
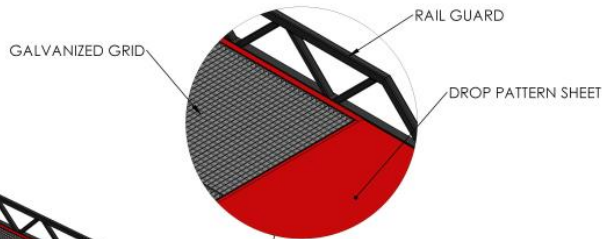
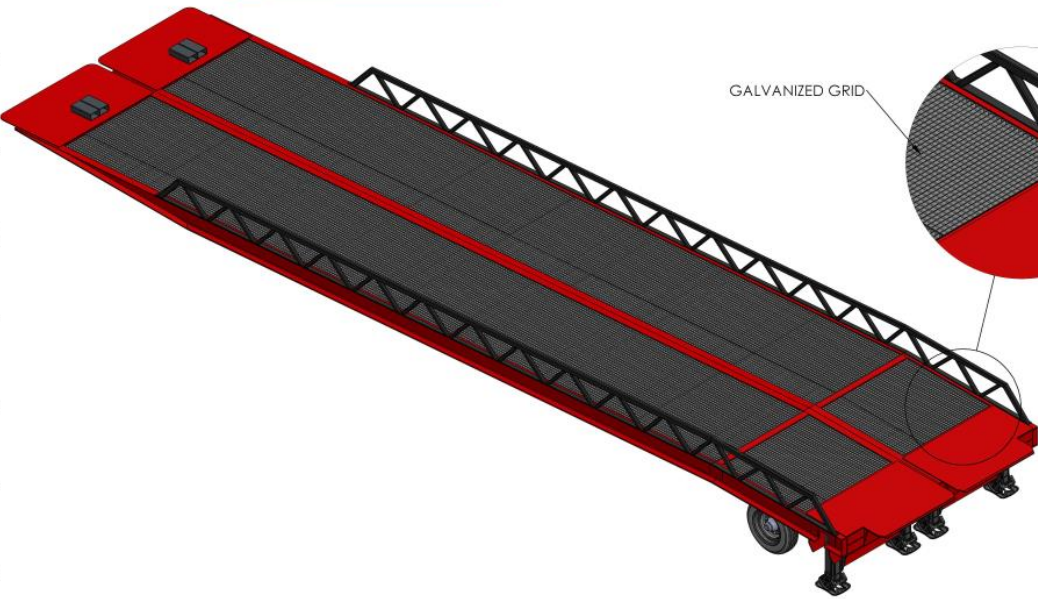
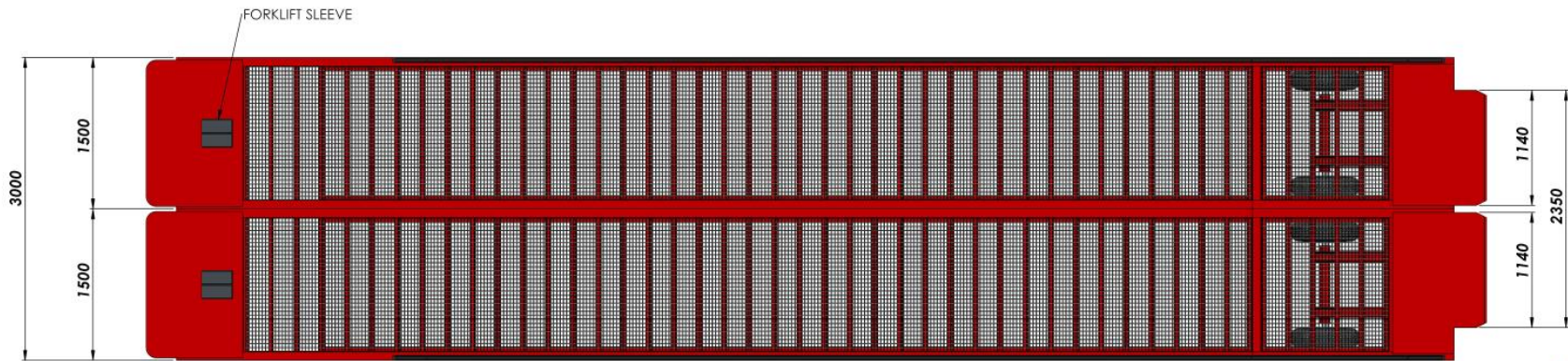
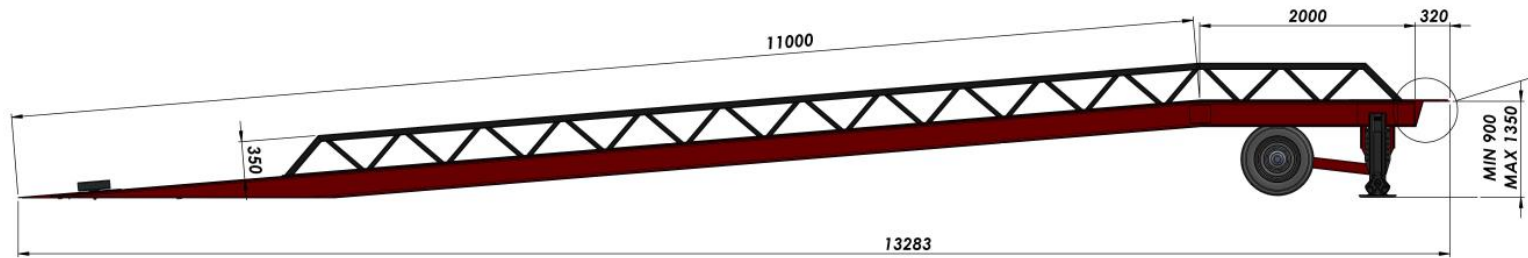

CAPACITY: 15 TONS

NAME - SURNAME	DATE	SIGN	QUANTITY	MASS (KG)	MATERIAL	PAGE NR
DRAWN BY: H. CANSEVER	30.03.2022		---			1/1
CONTROL: A. HEPBILDI	30.03.2022					
APPROVAL: S. ENTZMANN	30.03.2022					
SCALE: 1:50						
PART/ASSEMBLY NAME	DRAWING DESCRIPTION		DRAWING NO.			
	#3WPK		--- #688B			



AZ MACHINERY - SLU, Matériels d'Élévation et Maintenance
 13 rue de la source - 36 340 PALLATI DE CERBACHNOY - France
 Téléphone : +33 (0) 27 48 300 - contact@az-machinery.com - www.az-machinery.com
 Site : 424 654 958 666 19 - TVA : FR02 824 654 958 - N° EORI : FR02 824 654 958

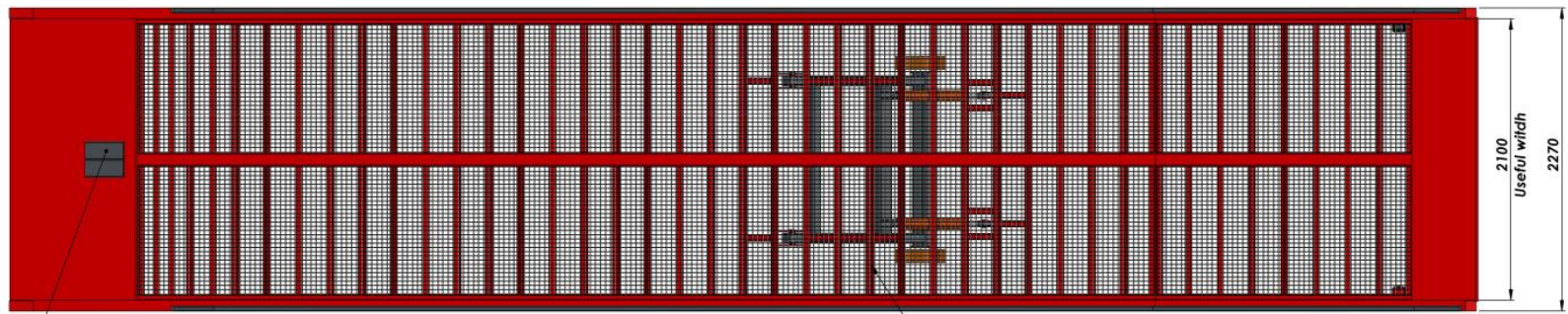
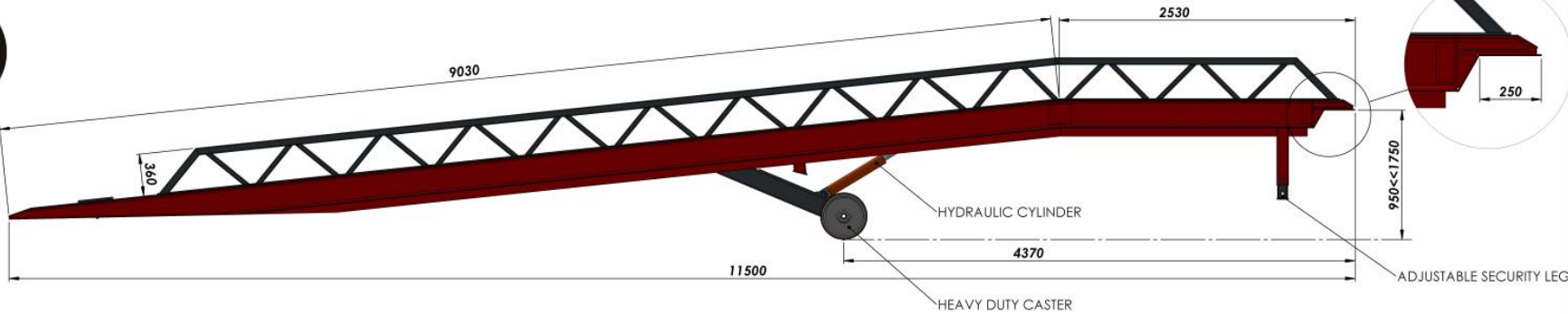

FORKLIFT SLEEVE

ALL FLOOR IS GALVANIZED GRID

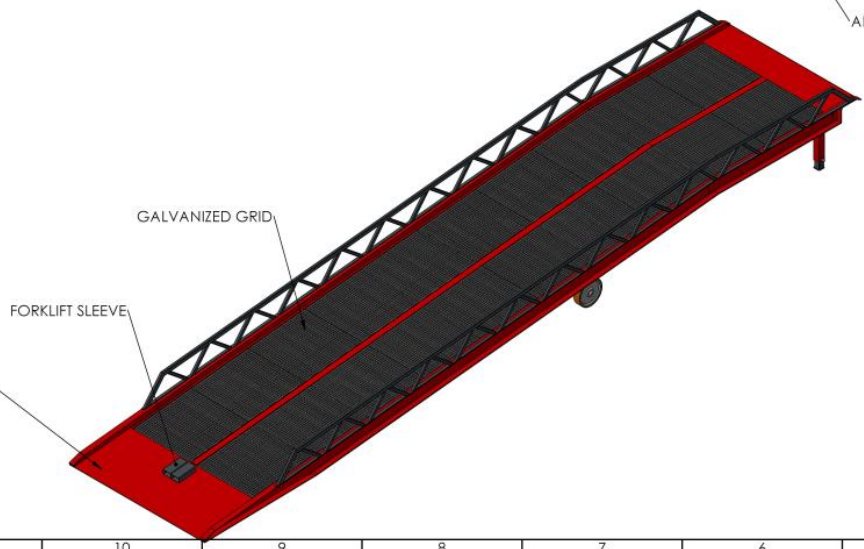

NAME - SURNAME	DATE	SIGN	QUANTITY	MASS (KG)	MATERIAL	PAGE NR
DRAWN BY: H. CANSEVER	30.09.2022		---			1/2
CONTROL: A. HEPBILDI	30.09.2022					
APPROVAL: S. ENTZMANN	30.09.2022					
SCALE: 1:50						
PART/ASSEMBLY NAME	DRAWING DESCRIPTION:		DRAWING NO.			
	#D47X		---			



AZ MACHINERY - SLU, Matériels d'Élévation et Manutention
 13 rue de la source - 66340 PALLAS DE CERDANNE - France
 Téléphone : +33 (0) 37 48 500 - contact@az-machinery.com - www.az-machinery.com
 Site : 424 654 958 666 19 - TVA : FR02 824 654 958 - N° EORI : FR02 824 654 958

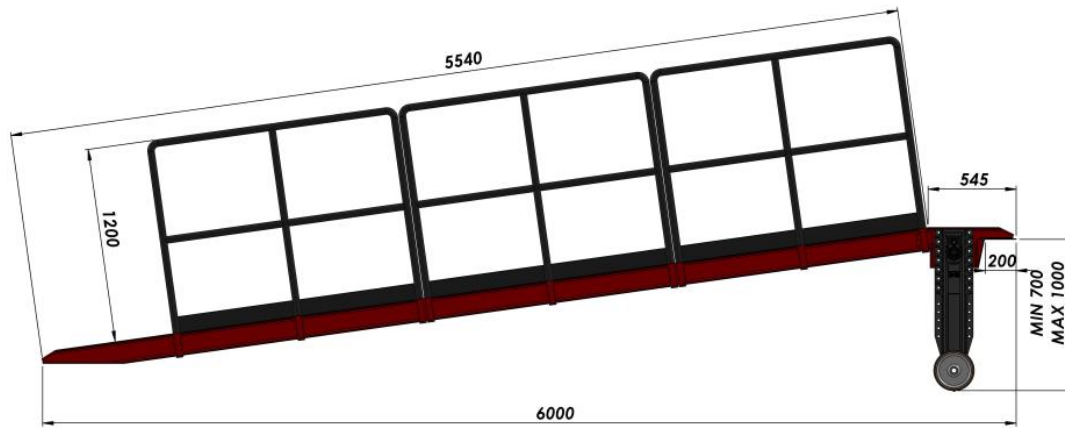

ALL FLOOR IS DROP PATTERN SHEET

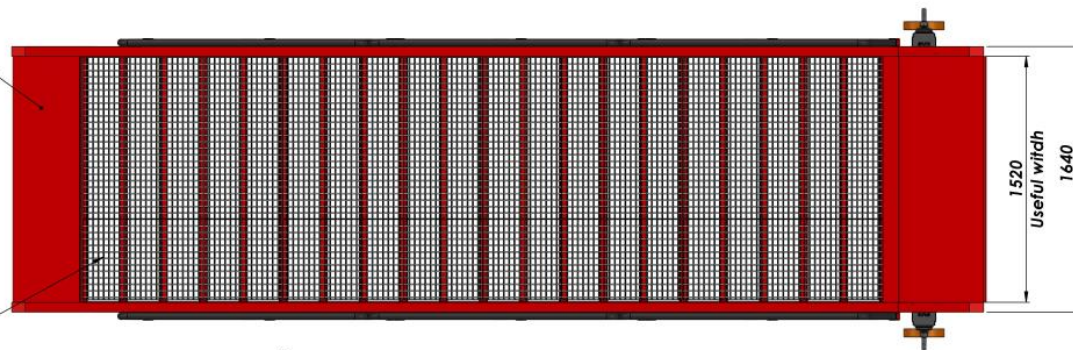

GALVANIZED GRID

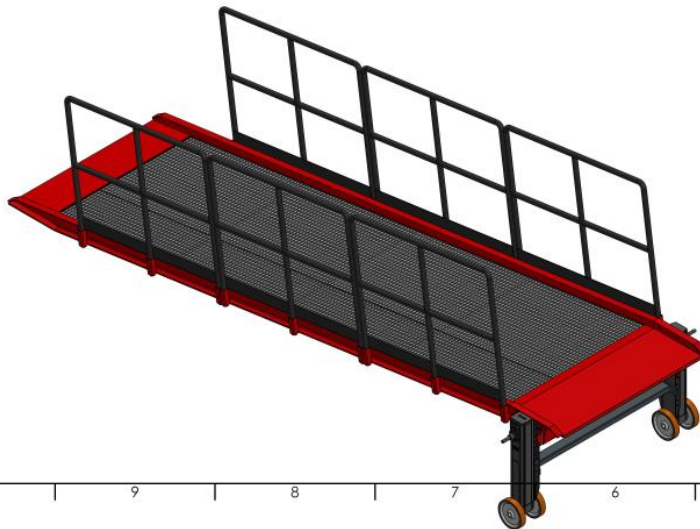

CAPACITY: 3000 KG

NAME-SURNAME	DATE	SIGN	QUANTITY	MASS (KG)	MATERIAL	PAGE NR
DRAWN BY: H. CANSEVER	26.04.2022		---			1/1
CONTROL: A. HEPBILDI	26.04.2022					
APPROVAL: S. ENTZMANN	26.04.2022					
SCALE: 1:50						
PARTS/ASSEMBLY NAME			DRAWING DESCRIPTION		DRAWING NO.	
			#TS98 Ramp for commercial vehicles		---	



AZ MACHINERY - SLU, Matériels d'Élévation et Maintenance
 13 rue de la scierie - 66340 PLATZ DE CERBACHES - France
 Téléphone : +33 (0) 37 48 300 contact@az-machinery.com www.az-machinery.com
 Site : 424 654 958 666 19 - TVA : FR02 824 654 958 - N° EORI : FR02 824 654 958



DRAWINGS

Rampes mobiles

Rampes fixes

Plateformes logistiques

Rampes de quai

Réhausse

Tables de quai mobiles

Tables de quai fixes

Passerelles

Rampes pour conteneurs

Niveleurs

Fournitures de quai

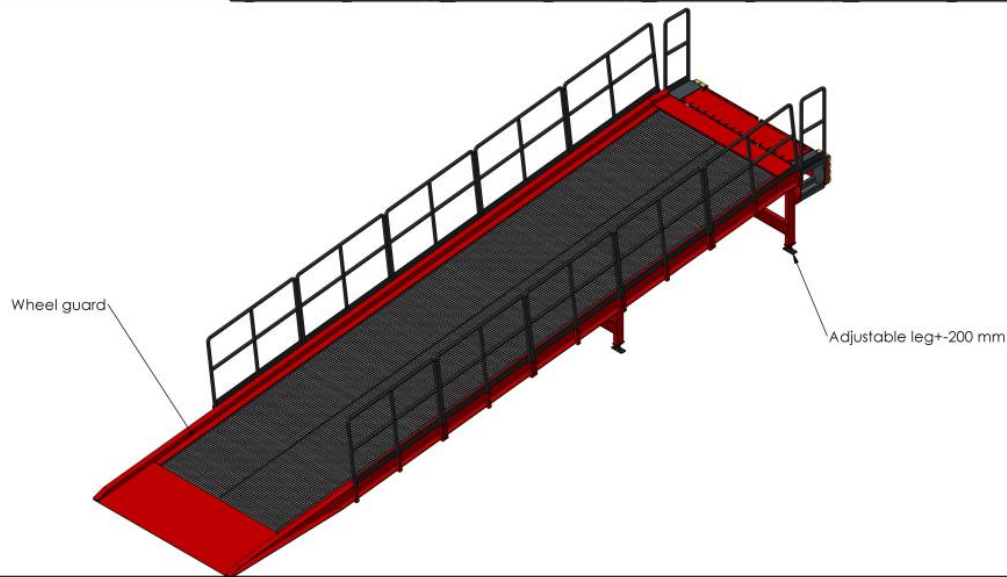
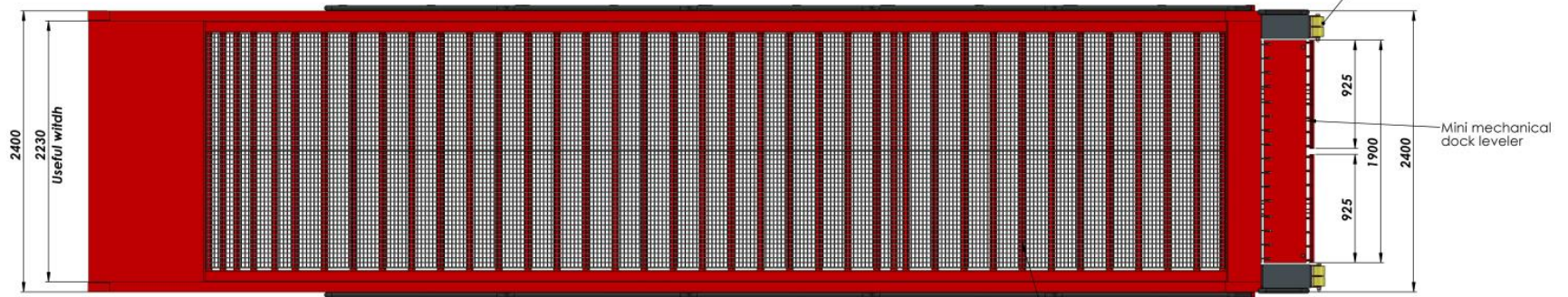
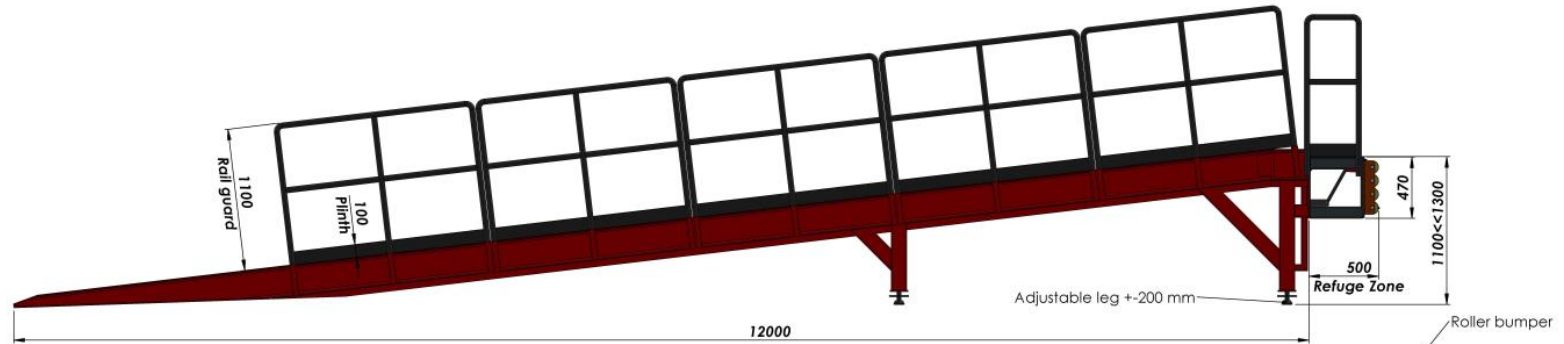

All floor is galvanized grid

NAME - SURNAME	DATE	SIGN	QUANTITY	MASS (KG)	MATERIAL	PAGE NR
DRAWN BY H. CANSEVER	14.10.2022		---			1/2
CONTROL A. HEPBILDI	14.10.2022					
APPROVAL S. ENTZMANN	14.10.2022					
SCALE 1:50						
PART/ASSEMBLY NAME	DRAWING DESCRIPTION		DRAWING NO.			
	#63LP		---			



AZ MACHINERY - SLU, Matériels d'Élévation et Maintenance
 13 rue de la source - 16 540 PULLEY DE CEEBACHEN - France
 Téléphone : +33 (0) 37 48 500 - contact@az-machinery.com - www.az-machinery.com
 Site : 824 654 958 000 FR - TVA : FR02 824 654 958 - 3^e EORL - FR02 824 654 958

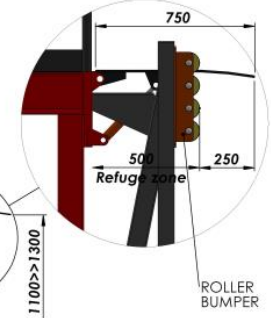
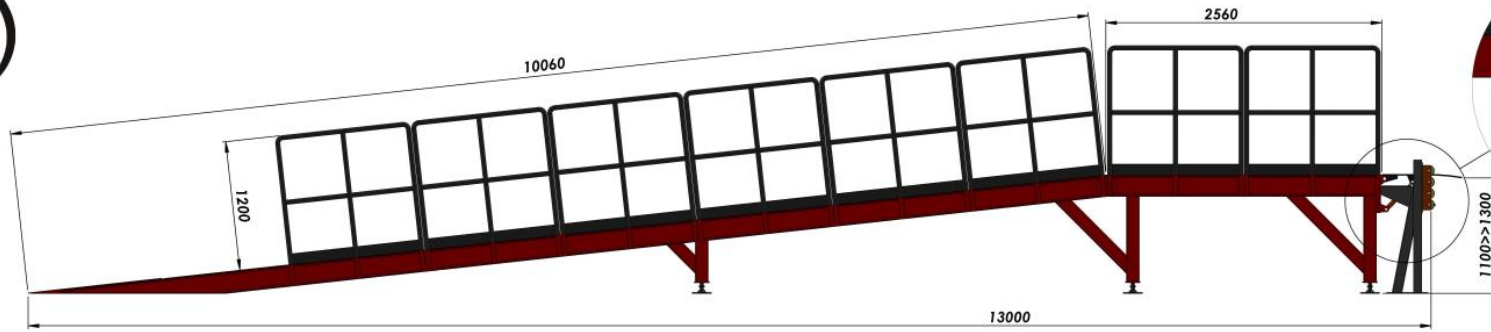

ROLLER BUMPER

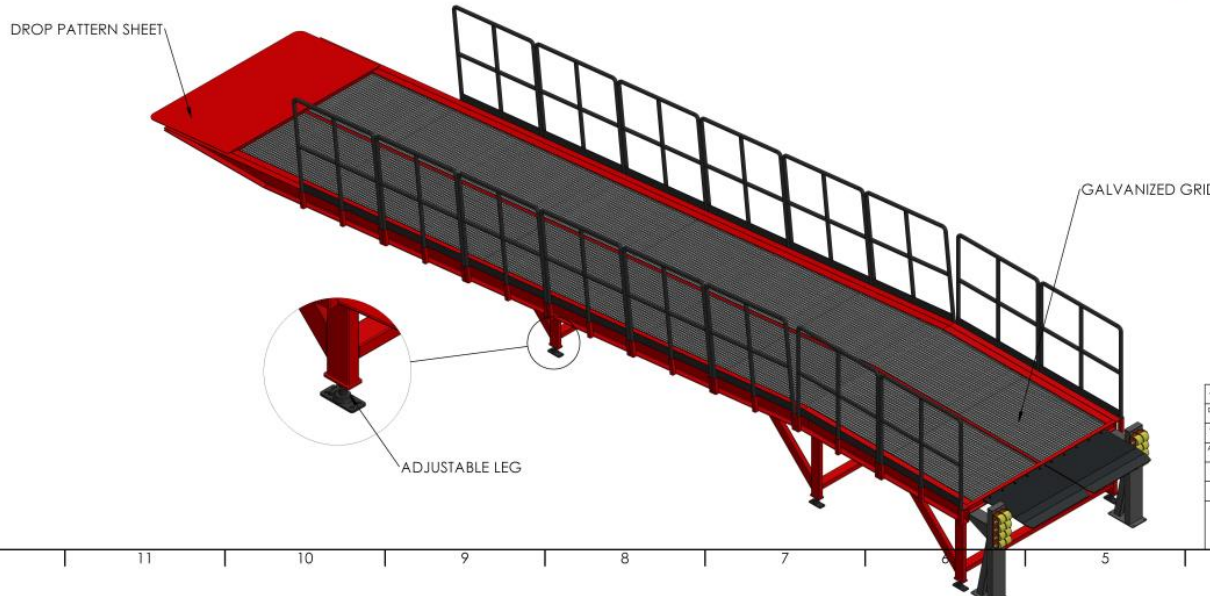
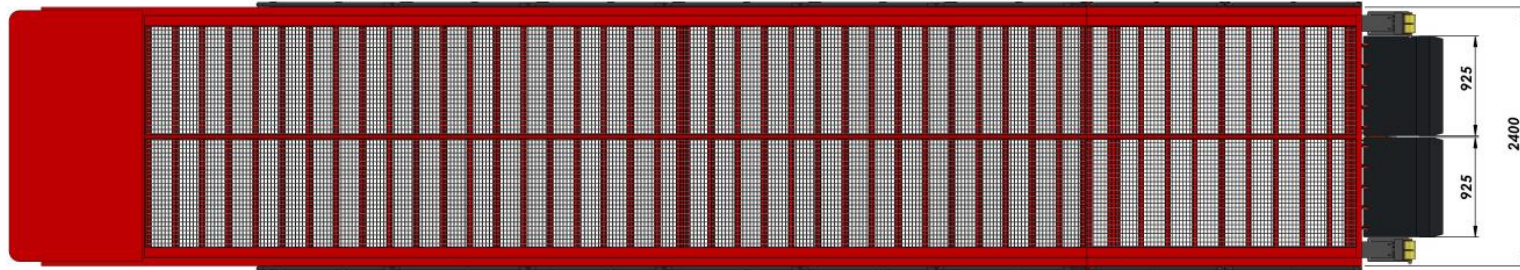

NAME - SURNAME	DATE	SIGN	QUANTITY	MASS (KG)	MATERIAL	PAGE NR
DRAWN BY H. CANSEVER	31.08.2022		---			1/2
CONTROL A. HEPBILDI	31.08.2022					
APPROVAL S. ENTZMANN	31.08.2022					
SCALE 1:50						
PART/ASSEMBLY NAME	DRAWING DESCRIPTION		DRAWING NO.			
	#8FB4		---			



AZ MACHINERY - SLU, Matériels d'Élévation et Manutention
 13 rue de la source - 46 540 PÉLAGY DE CÉBERACONS - France
 Téléphone : +33 (0) 37 48 300 - contact@az-machinery.com - www.az-machinery.com
 Site : 824 654 958 000 FR - TVA : FR02 824 654 958 - 3° EORI : FR02 824 654 958

20

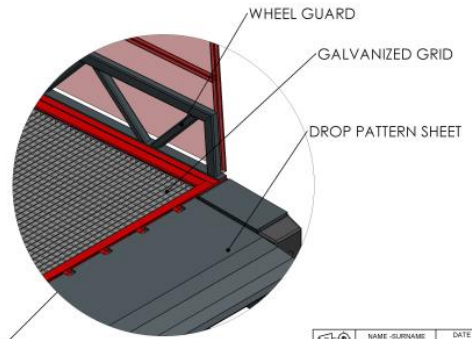
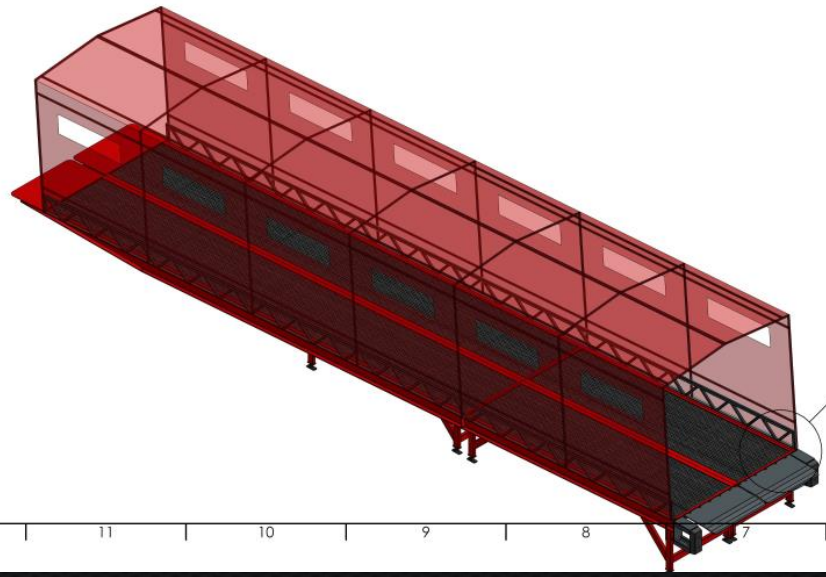
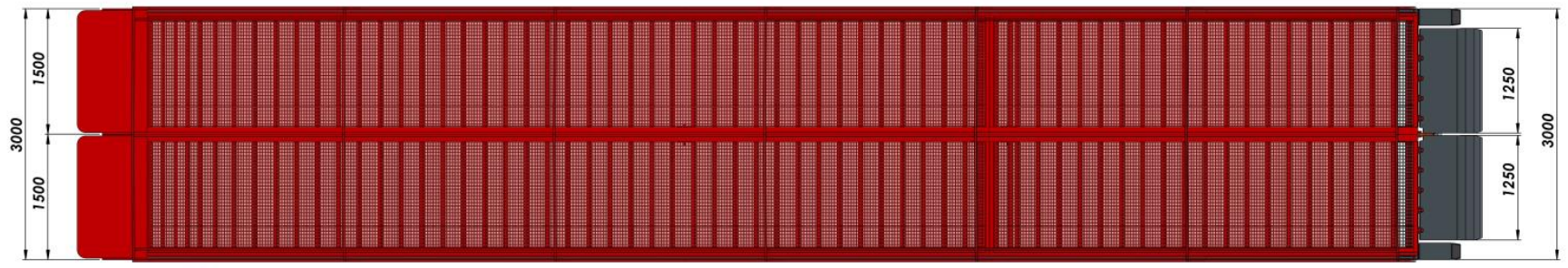
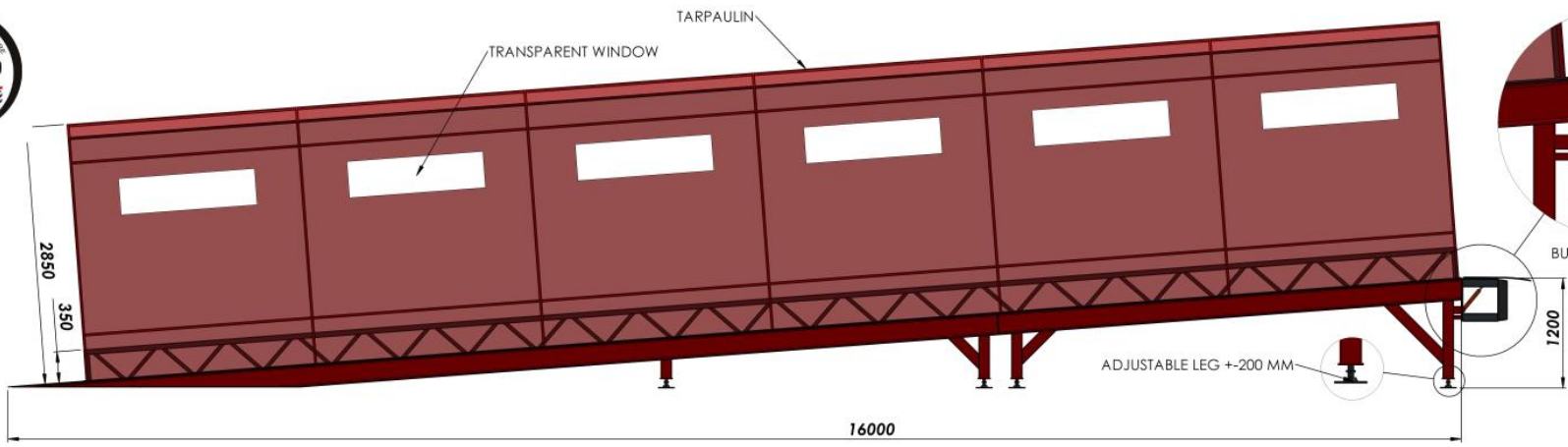

CAPACITY: 16000 KG DYNAMIC

NAME - SURNAME	DATE	SIGN	QUANTITY	MASS (KG)	MATERIAL	PAGE NR
DRAWN BY H. CANSEVER	27.03.2022		---			1/1
CONTROL A. HEPBILDI	27.03.2022					
APPROVAL S. ENTZMANN	27.03.2022					
SCALE 1:100						
PARTASSEMBLY NAME	DRAWING DESCRIPTION		DRAWING NO.			
	#SK.G2		---			



AZ MACHINERY - SLU, Matériels d'Élévation et Maintenance
 13 rue de la source - 66 340 PULIAT DE CEBRANCOIS - France
 Téléphone : +33 (0) 37 48 300 - contact@az-machinery.com - www.az-machinery.com
 Site : 824 654 958 000 FR - TVA : FR02 824 654 958 - N° EORI : FR02 824 654 958

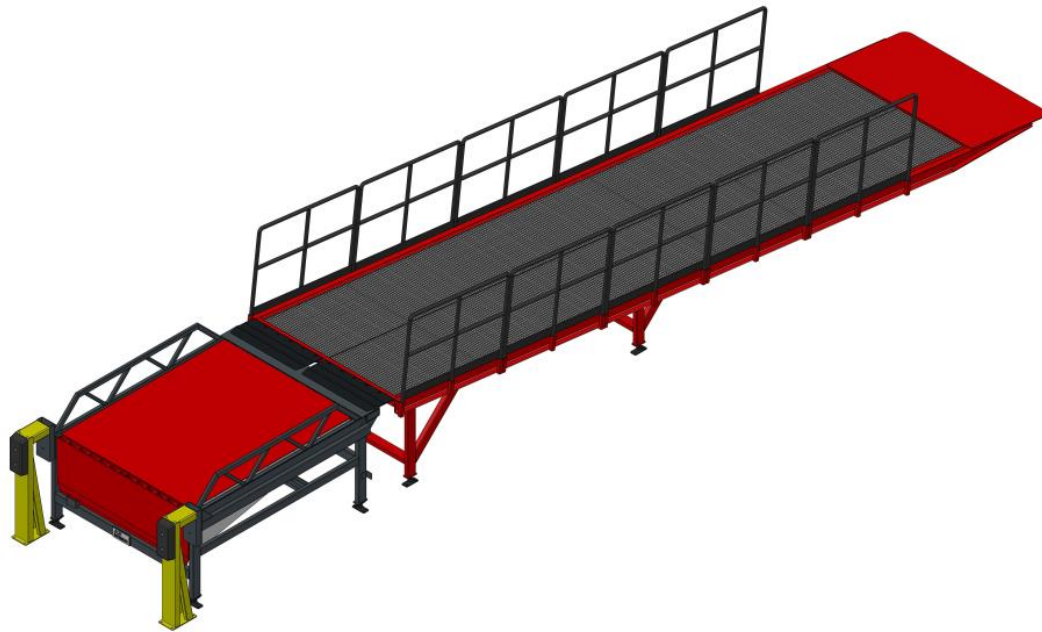
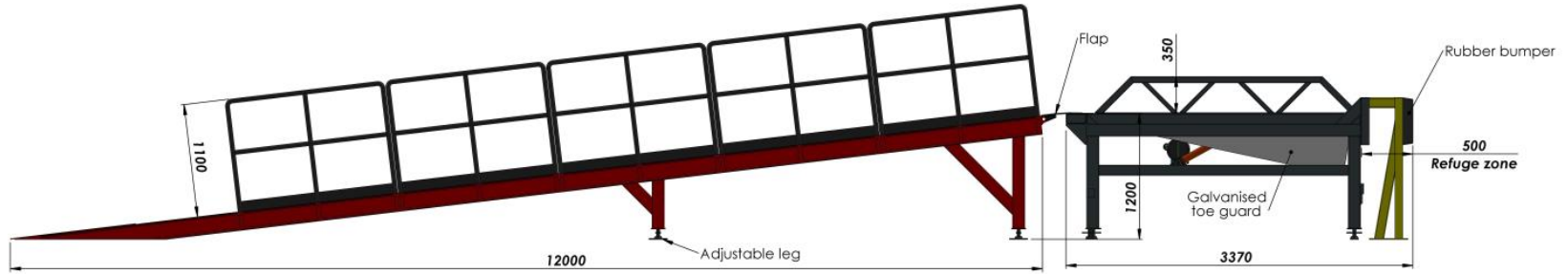

HINGED LIP DOCK LEVELER FEATURES

1. CE Certificate approved
2. Compatible with EUROPEAN STANDARD EN 1398
3. 750 mm hinged flap
4. Platform dimensions 2000 x 2500
5. Ramp dynamic carrying capacity 10.000 kg,
6. Platform floor consists of 6/7 mm sheet with tear pattern and material used are made of St-37.2
7. Hinged flap consist of 12/13 mm sheet with tear pattern and
8. Easy to maintain, parts designed to be interchangeable, material used are made of St-52.2
9. Maximum operating slope 12.5% (7 °),
10. Has a security lock,
11. It has galvanized side protection sheets in accordance with the safety standard,
12. Has a maintenance bar,
13. tWO pistons for lifting the ramp platform and a hydraulic piston that moves the front tongue (moving lip)
14. Nominal working range + 400 / -400 mm
15. 35 mm galvanized shafts,
16. Steel construction designed for load distribution,
17. Flap 1 hydraulic piston works. (outer diameter min.50 mm, rod diameter 28 mm),
18. Platform floor movement with double hydraulic pistons (outer diameter min.60mm, rod diameter 36mm),
19. The mobility of the platform floor with the electro-hydraulic system,
20. It has hydraulic emergency deceleration mechanism,
21. Hydraulic unit Brevini
22. Motor Voltage 3 Phase 380/400 V, 50 Hz, power at least 0.75 kW,
23. It has a control panel that can control the system,
24. Control panel has IP65 protection class,
25. Solenoid coil lock to prevent the platform from going down when it is de-energized,
26. -10/+40 operating temperature
27. Rubber bumper montage on ramp walls: 450 * 200 * 100 mm, 10 kg and 70 shore hardness.
28. RAL 3002 and RAL 9005 color acrylic paint, cleaned with thinner before painting and painted with epoxy primer,

NAME - SURNAME	DATE	SIGN	QUANTITY	MASS (KG)	MATERIAL	PAGE NR
H. CANSEVER	04.03.2023		---			1/2
A. HEPBILDI	04.03.2023					
S. ENTZMANN	04.03.2023					
PART/ASSEMBLY NAME		DRAWING DESCRIPTION		DRAWING NO.		
		#8426		---		



AZ MACHINERY - SLU, Matériels d'Élévation et Maintenance
 13 rue de la saule - 16 540 PÉLASSY DE CÉDERNANS - France
 Téléphone : +33 (0) 37 48 500 - contact@az-machinery.com - www.az-machinery.com
 Site : 824 654 958 000 FR - TVA : FR02 824 654 958 - N° EORI : FR02 824 654 958

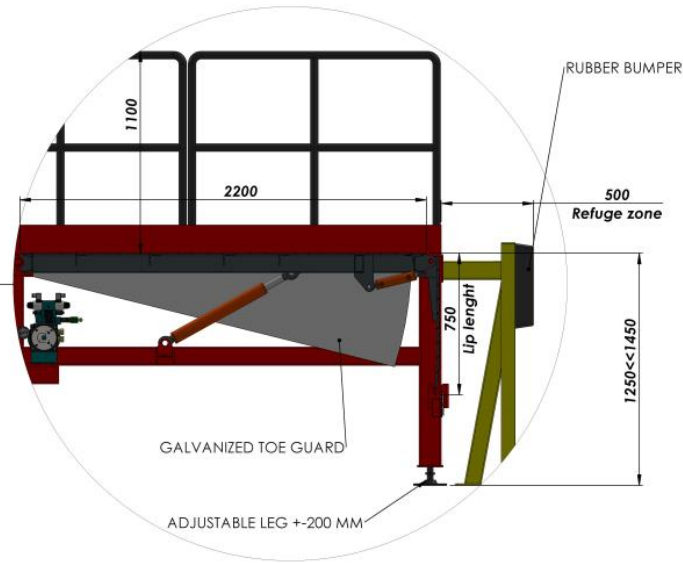
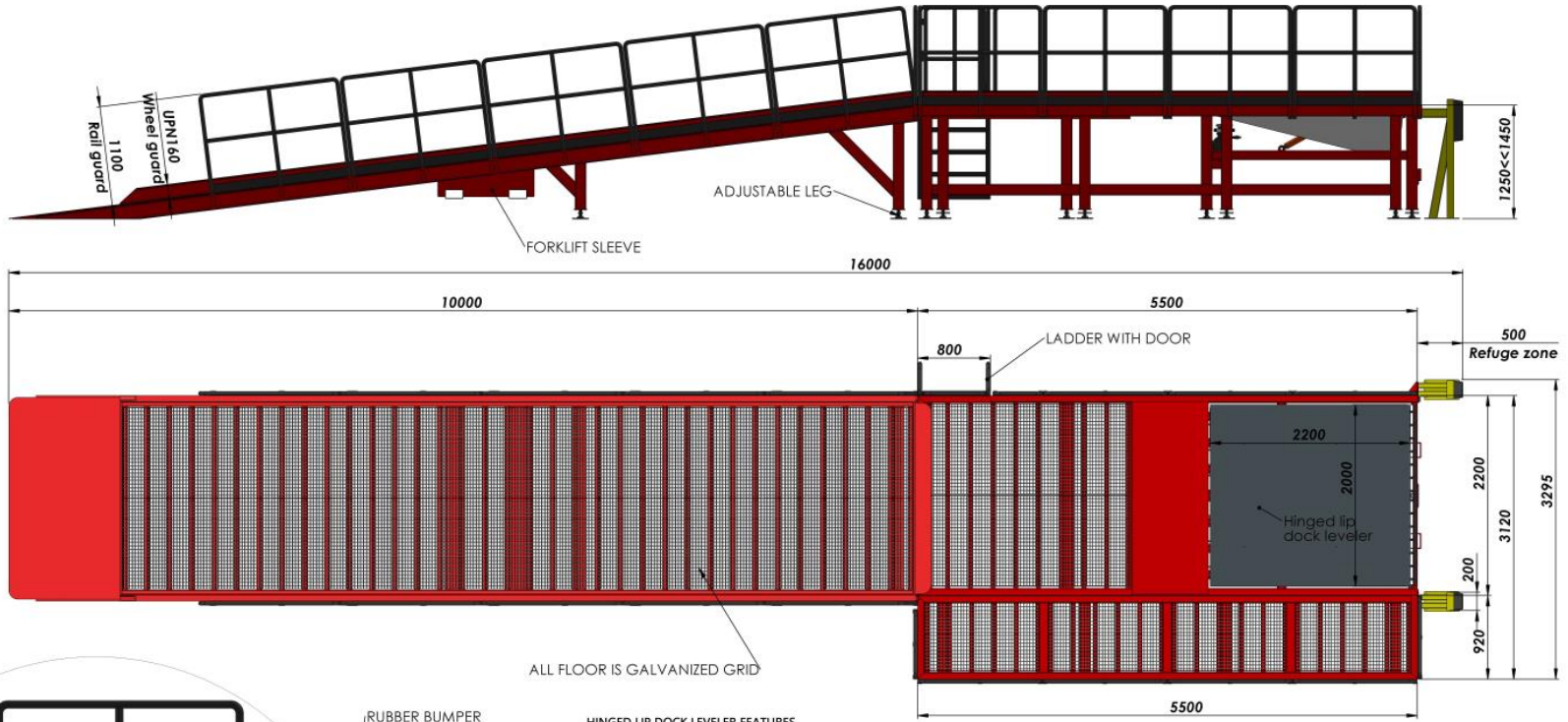

ALL FLOOR IS GALVANIZED GRID

HINGED LIP DOCK LEVELER FEATURES

- ✓ 750 mm hinged flap
- ✓ Platform dimensions 2000 x2200
- ✓ Ramp dynamic carrying capacity 8.000 kg.
- ✓ Compatible with EUROPEAN STANDARD EN 1398
- ✓ CE Certificate approved
- ✓ Platform floor consists of 6/7 mm sheet with tear pattern
- ✓ Hinged flap consist of 12/13 mm sheet with tear pattern
- ✓ Easy to maintain, parts designed to be interchangeable,
- ✓ maximum operating slope 12.5% (7 °),
- ✓ Has a security lock,
- ✓ It has galvanized side protection sheets in accordance with the safety standard,
- ✓ Has a maintenance bar,
- ✓ 2 pistons for lifting the ramp platform and a hydraulic piston that moves the front tongue (moving lip)
- ✓ Nominal working range + 450 / -420 cm
- ✓ Platform sheet material and other steel material used are made of St-37.2
- ✓ Flap material used is made of St-52
- ✓ 35 mm galvanized shafts,
- ✓ Steel construction designed for load distribution,
- ✓ Flap 1 hydraulic piston works. (outer diameter min.50 mm, rod diameter 28 mm),
- ✓ Platform floor movement with double hydraulic pistons (outer diameter min.60mm, rod diameter 36mm),
- ✓ The mobility of the platform floor with the electro-hydraulic system,
- ✓ It has hydraulic emergency deceleration mechanism,
- ✓ Hydraulic unit Brevini
- ✓ Motor Voltage 3 Phase 380/400 V, 50 Hz, power at least 0.75 kW,
- ✓ It has a control panel that can control the system,
- ✓ Control panel has IP65 protection class,
- ✓ Solenoid coil lock to prevent the platform from going down when it is de-energized,
- ✓ -10/+40 operating temperature
- ✓ Rubber bumper montaged on ramp walls: 450 * 200 * 100 mm, 10 kg and 70 shore hardness.
- ✓ RAL 3002 and RAL 9005 color acrylic paint, cleaned with thinner before painting and painted with epoxy primer,

NAME	SURNAME	DATE	SIGN	QUANTITY	MASS (KG)	MATERIAL	PAGE NR
DRAWN BY	H. CANSEVER	05.11.2022		---			1/2
CONTROL	A. HEPBILDI	05.11.2022					
APPROVAL	S. ENTZMANN	05.11.2022					
SCALE	1:100						
PART/ASSEMBLY NAME				DRAWING DESCRIPTION		DRAWING NO.	
				#JB7B		---	



AZ MACHINERY - SLU, Matériels d'Élévation et Manutention
 13 rue de la source - 16 540 PÉLASSI DE CEEBACHEN - France
 Téléphone : +33 (0) 37 48 500 - contact@az-machinery.com - www.az-machinery.com
 Site : AZ 654 958 000 FR, TVA : FR02 824 654 958 - 3° EORI : FR02 824 654 958

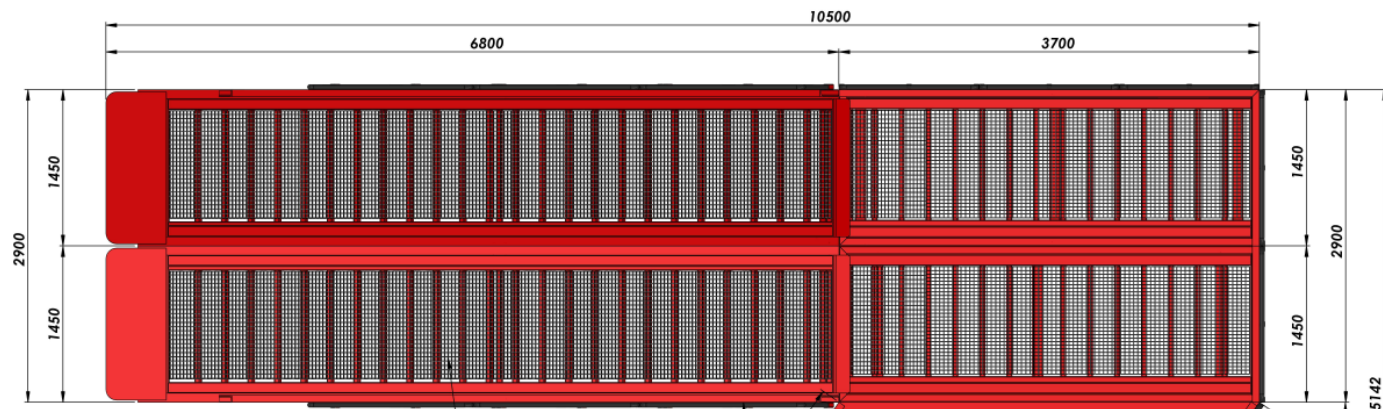

Galvanised grid

Drop pattern sheet

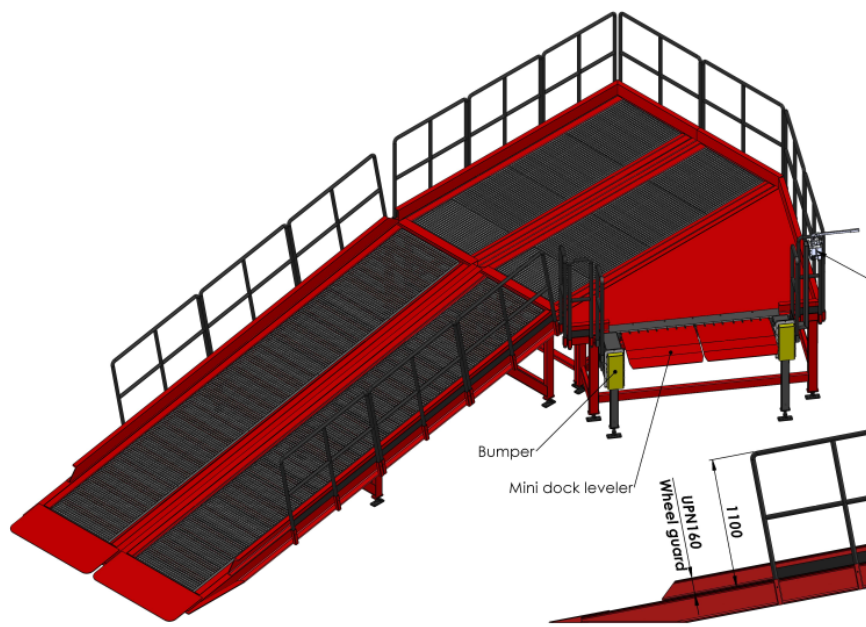

Hand pump

Bumper

Mini dock leveler

UPN160
Wheel guard

Mini dock leveler

Hand pump

Steel bumper

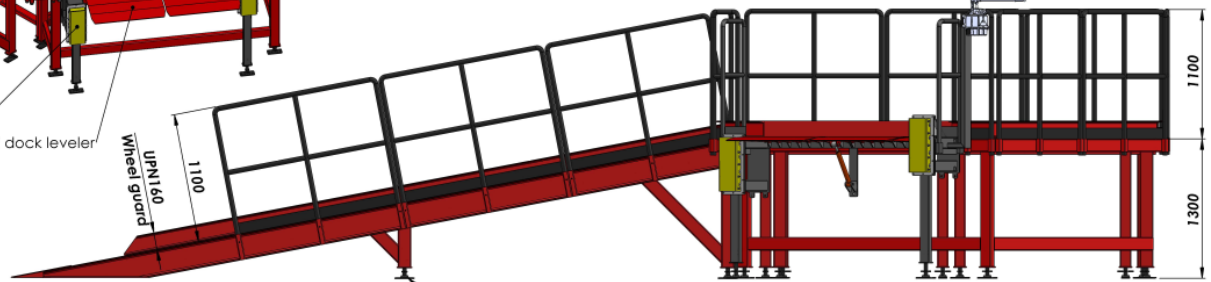

Adjustable leg

NAME - SURNAME	DATE	SIGN	QUANTITY	MASS (KG)	MATERIAL	PAGE NR
DRAWN BY: H. CANSEVER	18.10.2022		---			1/2
CONTROL: A. HEPBILDI	18.10.2022					
APPROVAL: S. ENTZMANN	18.10.2022					
SCALE: 1:100						
PART/ASSEMBLY NAME	DRAWING DESCRIPTION		DRAWING NO.			
	#786N		---			



AZ MACHINERY - SLU, Matériels d'Élévation et Maintenance
 13 rue de la scierie - 46 540 PUY-L'ÉVÊQUE - FRANCE
 Téléphone : +33 (0) 27 48 300 - contact@az-machinery.com - www.az-machinery.com
 Site : 824 654 958 000 FR - TVA : FR02 824 654 958 - N° EORI : FR02 824 654 958

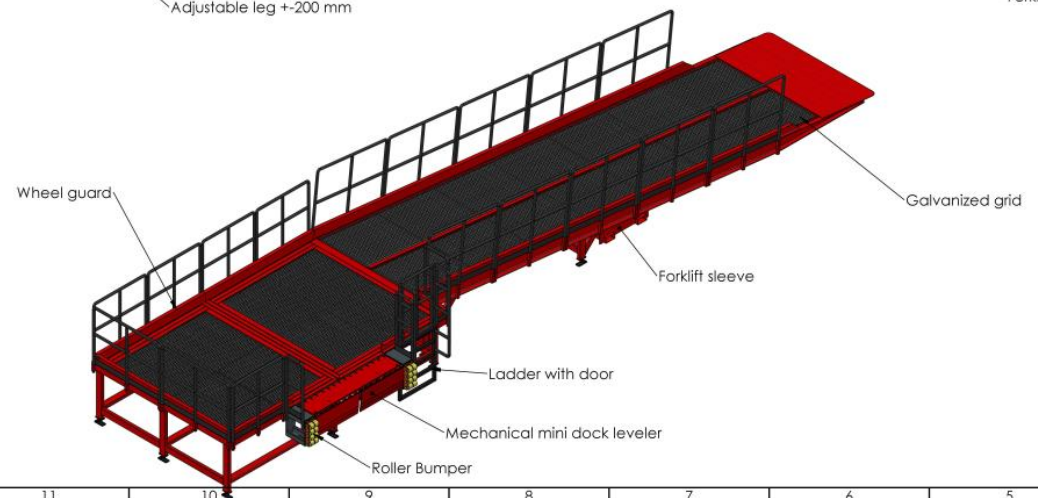
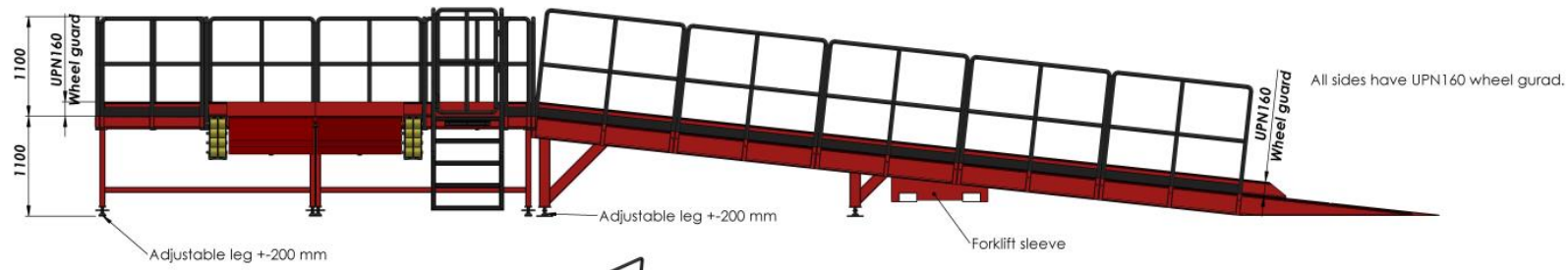
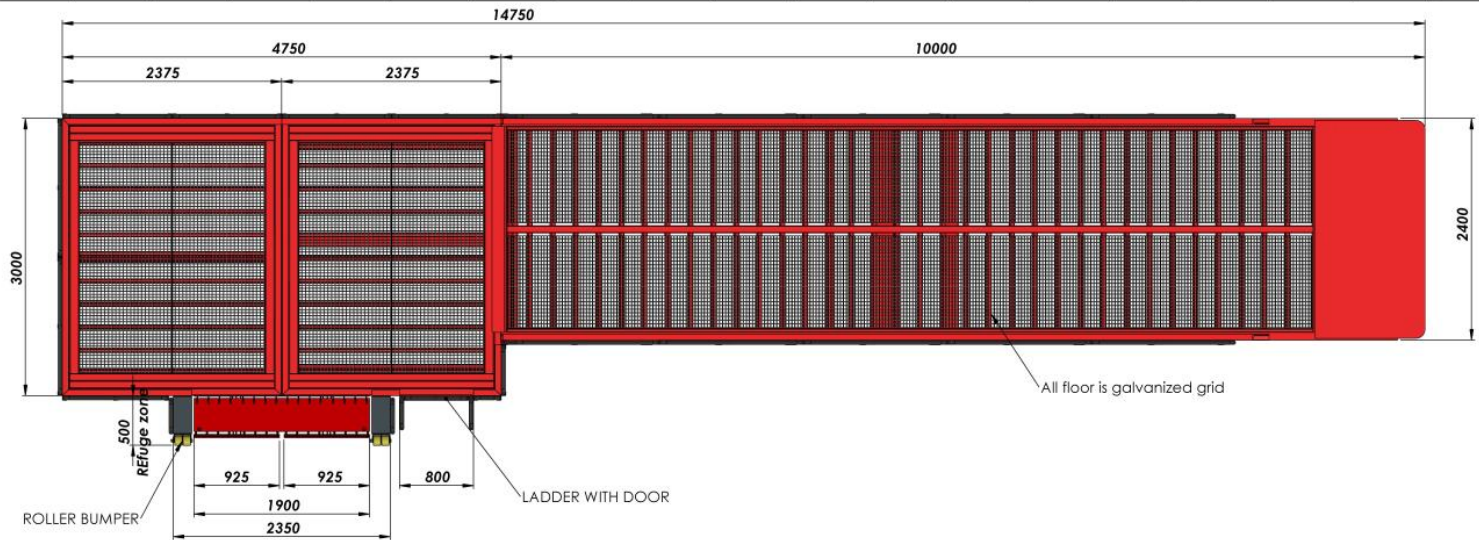

NAME - SURNAME	DATE	SIGN	QUANTITY	MASS (KG)	MATERIAL	PAGE/NT
DRAWN BY H. CANSEVER	14.10.2022		---			1/2
CONTROL A. HEPBILDI	14.10.2022					
APPROVAL S. ENTZMANN	14.10.2022					
SCALE 1:200						
PART/ASSEMBLY NAME	DRAWING DESCRIPTION		DRAWING NO.			
	#8JD3		---			



AZ MACHINERY - SLU, Matériels d'Élévation et Maintenance
 13 rue de la source - 10 540 PÉLASSY DE CEZANNES - France
 Téléphone : +33 (0) 37 46 500 contact@az-machinery.com www.az-machinery.com
 Site : 824 654 958 000 FR - TVA : FR02 824 654 958 - 3° EORL FR02 824 654 958

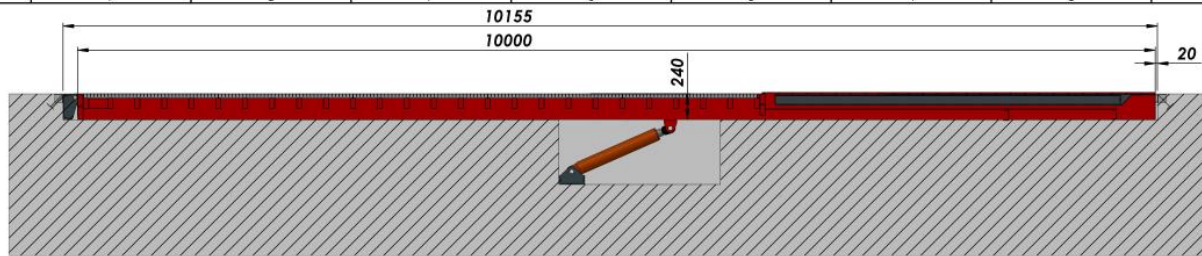

SECTION A-A

SCALE 1 : 30

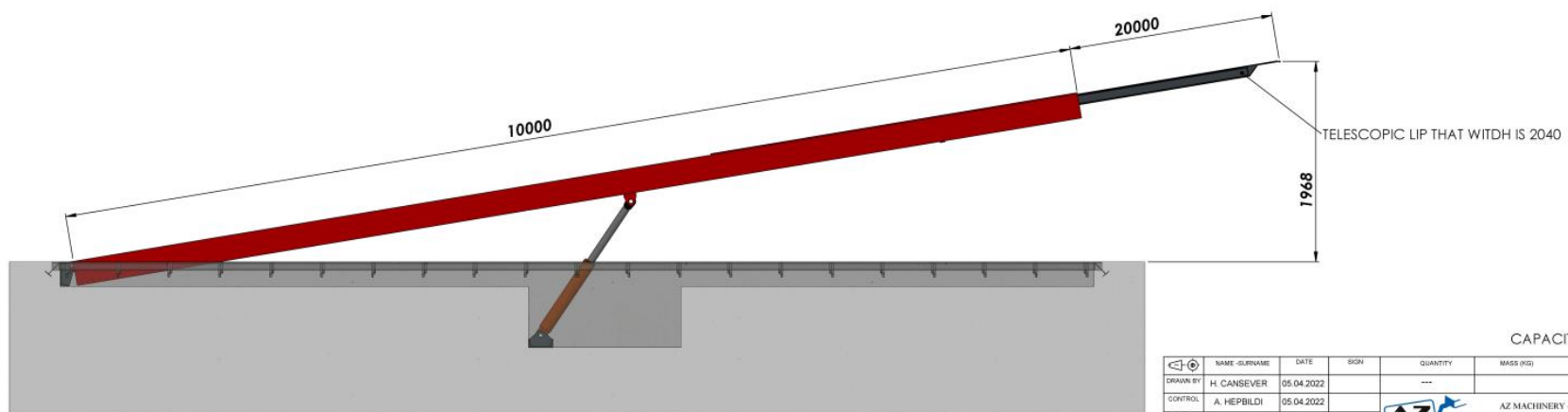
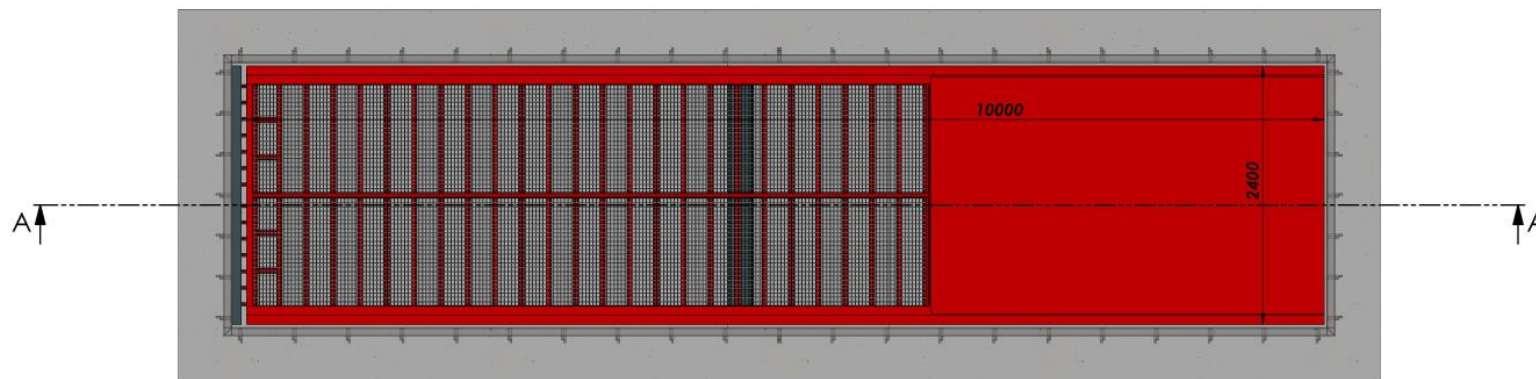

CAPACITY: 10000KG DYNAMIC

NAME - SURNAME	DATE	SIGN	QUANTITY	MASS (KG)	MATERIAL	PAGE NR
DRAWN BY: H. CANSEVER	05.04.2022		---			1/1
CONTROL: A. HEPBILDI	05.04.2022					
APPROVAL: S. ENTZMANN	05.04.2022					
SCALE: 1:100						
PART/ASSEMBLY NAME	DRAWING DESCRIPTION		DRAWING NO.			
#MDE36	#4KCH		---			



AZ MACHINERY - SLU, Matériels d'Élévation et Maintenance
 13 rue de la scierie - 86 340 PALAIS DE CÉRÉBIANCOIS - FRANCE
 Téléphone : +33 (0) 27 48 500 - contact@az-machinery.com - www.az-machinery.com
 Site : 824 654 958 000 FR - TVA : FR02 824 654 958 - 3° E0001 - FR02 824 654 958

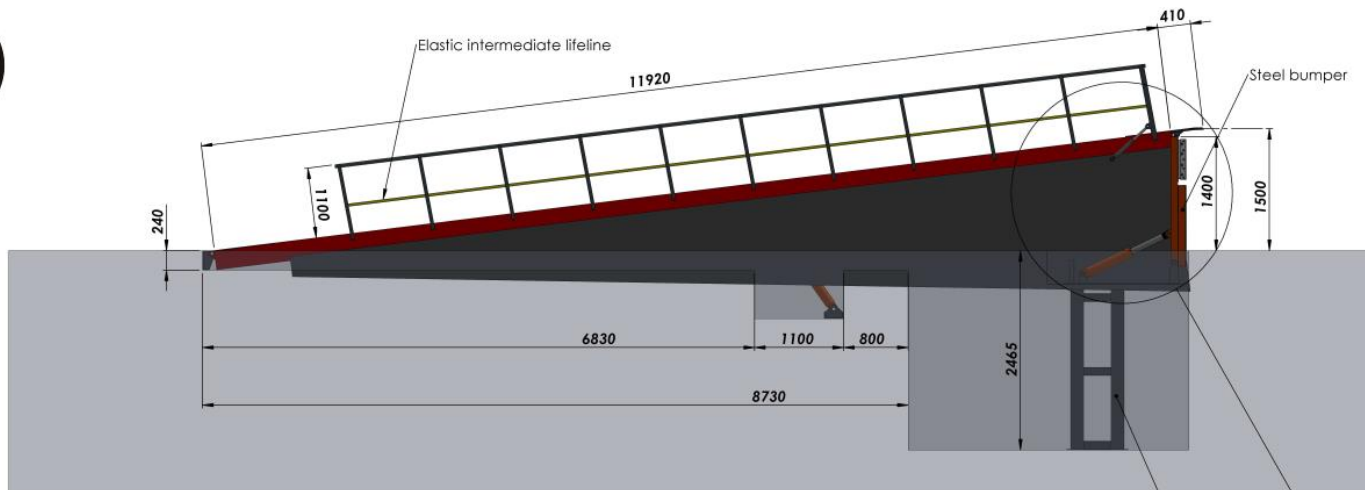

MAXIMUM WORKING POSITION

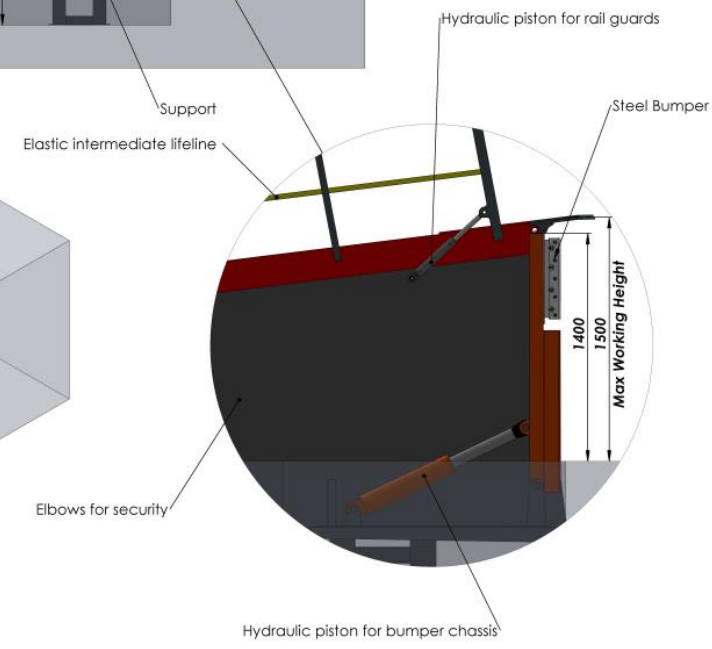
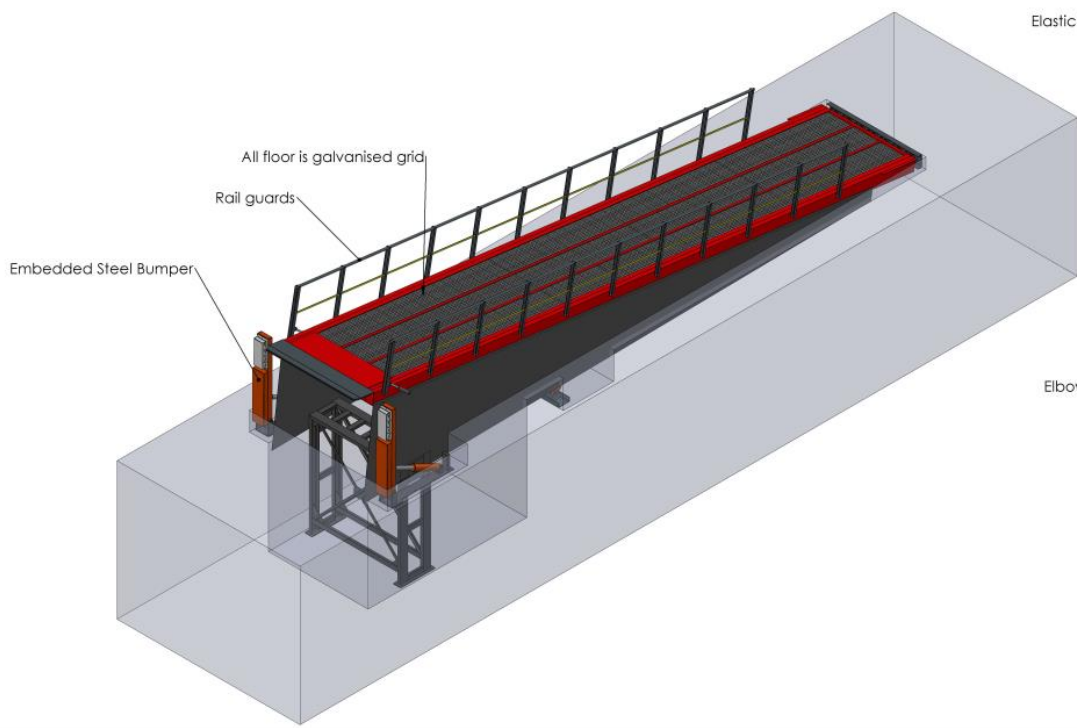

NAME - SURNAME	DATE	SIGN	QUANTITY	MASS (KG)	MATERIAL	PAGE/NT
DRAWN BY: H. CANSEVER	09.09.2022		---			1/2
CONTROL: A. HEPBILDI	09.09.2022					
APPROVAL: S. ENTZMANN	09.09.2022					
SCALE: 1:100						
PART/ASSEMBLY NAME	DRAWING DESCRIPTION:		DRAWING NO.:			
	#4KCH		---			



AZ MACHINERY - SLU, Matériels d'Élévation et Manutention
 13 rue de la source - 66 540 PUYLASSI DE CERDANNE - France
 Téléphone : +33 (0) 37 48 500 - contact@az-machinery.com - www.az-machinery.com
 Site : 824 654 958 000 FR - TVA : FR02 824 654 958 - N° EORI : FR02 824 654 958



DRAWINGS

Rampes mobiles

Rampes fixes

Plateformes logistiques

Rampes de quai

Réhausse

Tables de quai mobiles

Tables de quai fixes

Passerelles

Rampes pour conteneurs

Niveleurs

Fournitures de quai

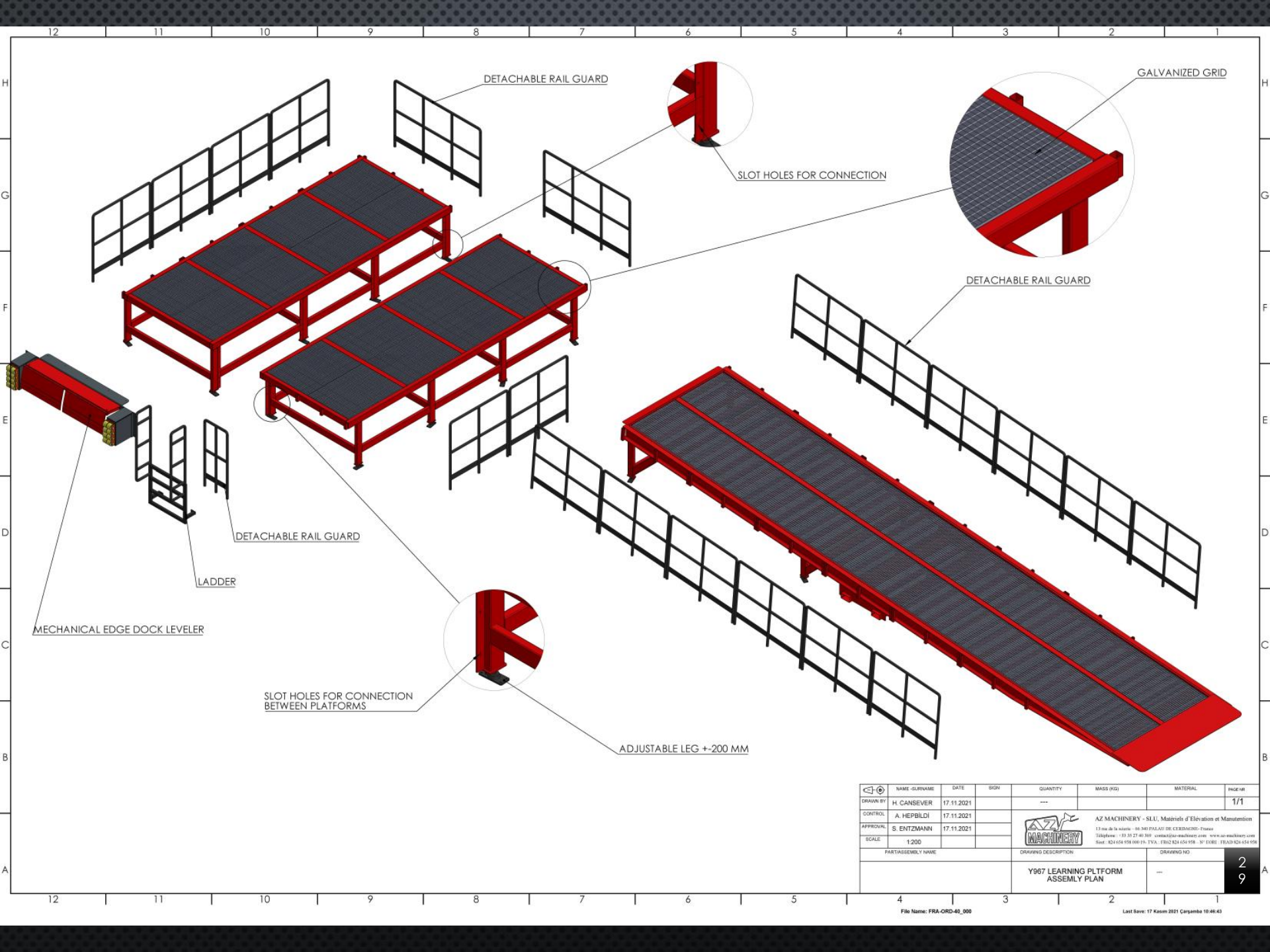

12 11 10 9 8 7 6 5 4 3 2 1

H
G
F
E
D
C
B
A

MECHANICAL EDGE DOCK LEVELER

LADDER

DETACHABLE RAIL GUARD

SLOT HOLES FOR CONNECTION BETWEEN PLATFORMS

ADJUSTABLE LEG +200 MM

DETACHABLE RAIL GUARD

SLOT HOLES FOR CONNECTION

DETACHABLE RAIL GUARD

GALVANIZED GRID

NAME - SURNAME	DATE	SIGN	QUANTITY	MASS (KG)	MATERIAL	PAGE NR
DRAWN BY: H. CANSEVER	17.11.2021		---			1/1
CONTROL: A. HEPBILDI	17.11.2021					
APPROVAL: S. ENTZMANN	17.11.2021					
SCALE: 1:200						
PART/ASSEMBLY NAME	DRAWING DESCRIPTION:		DRAWING NO.			
	Y967 LEARNING PLTFORM ASSEMBLY PLAN		---			

AZ MACHINERY
 AZ MACHINERY - SLU, Matériels d'Élévation et Maintenance
 13 rue de la machine - 46 340 PLAZAT DE CÉREACHON - France
 Téléphone : +33 (0) 27 46 500 - contact@az-machinery.com - www.az-machinery.com
 Site : 424 654 958 666 FR - TVA : FR02 824 654 958 - N° ED081 - REAO 824 654 958

12 11 10 9 8 7 6 5 4 3 2 1

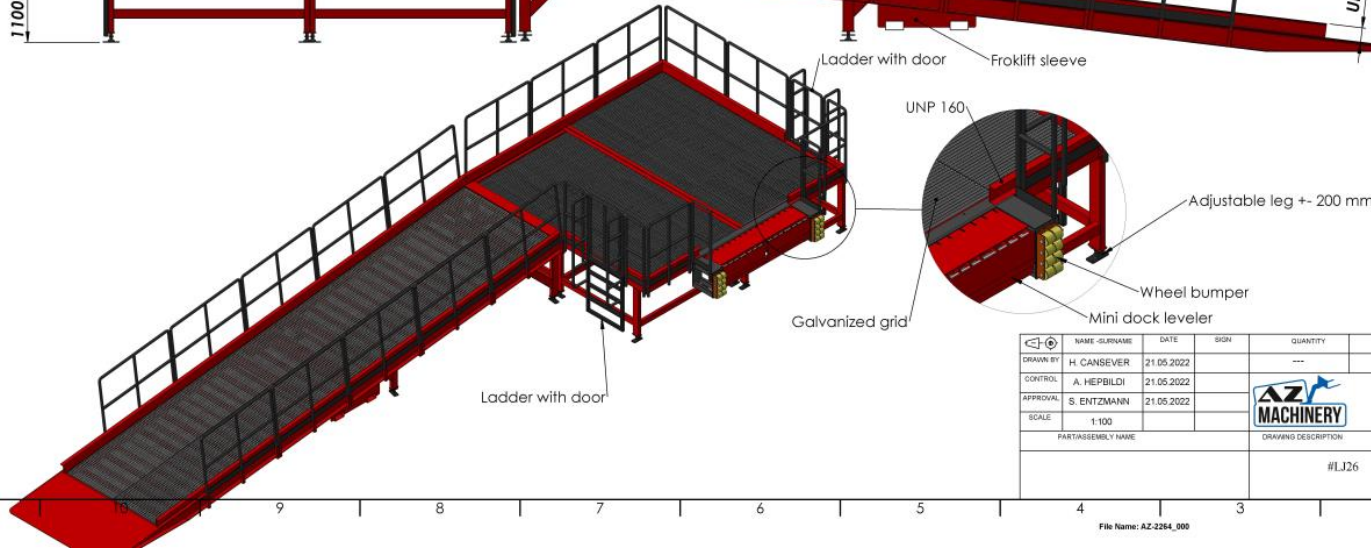
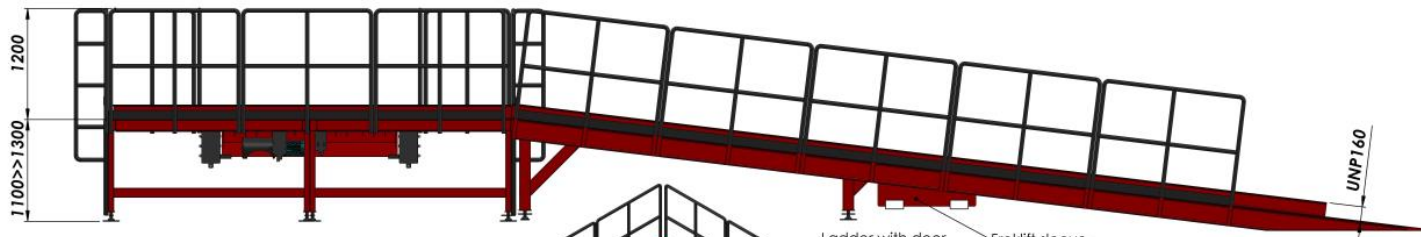
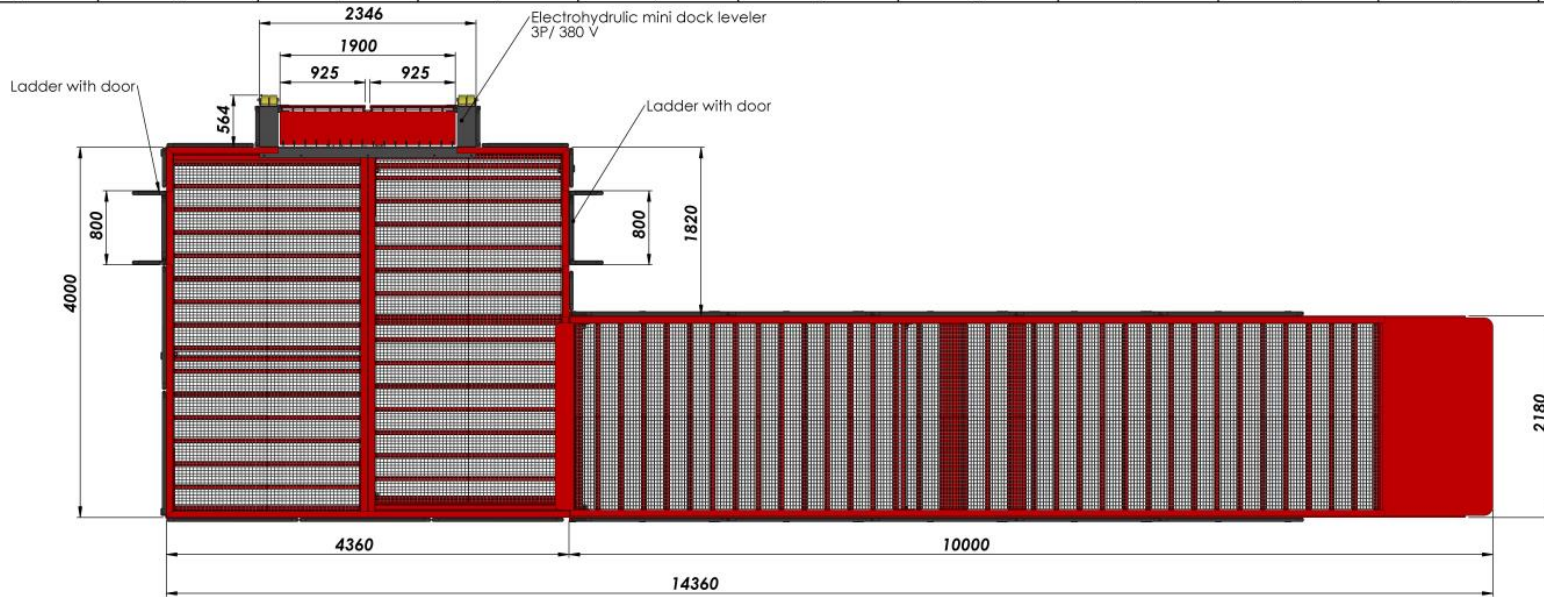

NAME - SURNAME	DATE	SIGN	QUANTITY	MASS (KG)	MATERIAL	PAGE/NT
H. CANSEVER	21.05.2022		---			1/1
A. HEBBILDİ	21.05.2022					
S. ENTZMANN	21.05.2022					
SCALE	1:100					
PART/ASSEMBLY NAME	DRAWING DESCRIPTION		DRAWING NO.			
	#LJ26		---			



AZ MACHINERY - SLU, Matériels d'Élévation et Manutention
 13 rue de la mairie - 66340 PLAILAT DE CERDANNE - France
 Téléphone : +33 (0) 37 46 500 - contact@az-machinery.com - www.az-machinery.com
 Site : 424 654 958 666 19 - TVA : FR02 824 654 958 - N° EORI : FR02 824 654 958



NAME - SURNAME	DATE	SIGN	QUANTITY	MASS (KG)	MATERIAL	PAGE NR
DRAWN BY: H. CANSEVER	19.11.2022		---			1/2
CONTROL: A. HEPBILDI	19.11.2022					
APPROVAL: S. ENTZMANN	19.11.2022					
SCALE: 1:100						
PART/ASSEMBLY NAME	DRAWING DESCRIPTION:		DRAWING NO.			
	#6F56		---			



AZ MACHINERY - SLU, Matériels d'Élévation et Maintenance
 13 rue de la source - 66340 PLAILLY DE CERDANNE - France
 Téléphone : 03 20 27 48 500 - contact@az-machinery.com - www.az-machinery.com
 Site : 624 654 958 666 19 - TVA : FR02 624 654 958 - N° EORI : FR02 624 654 958

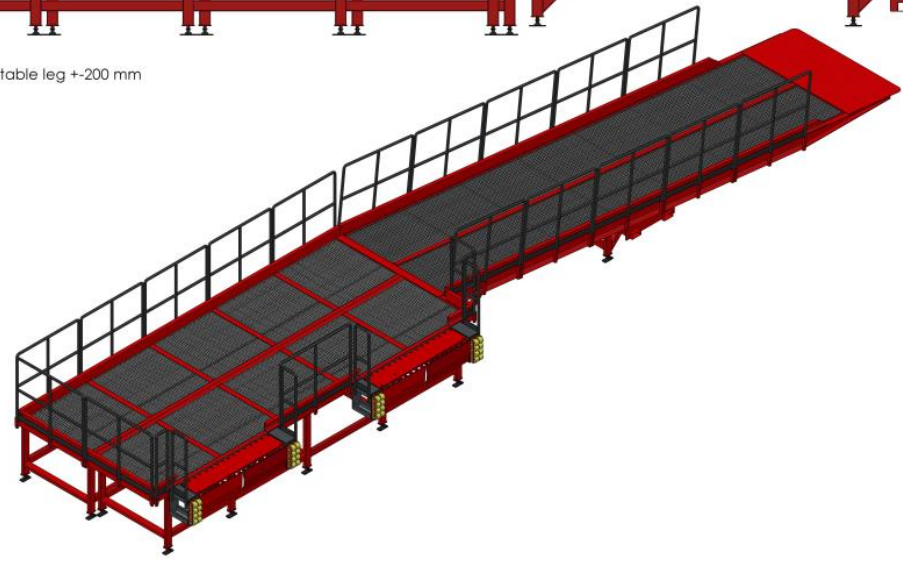
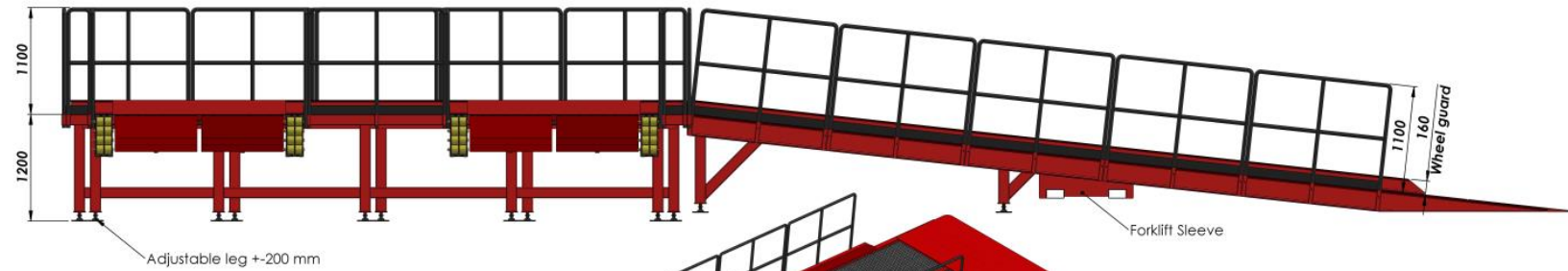
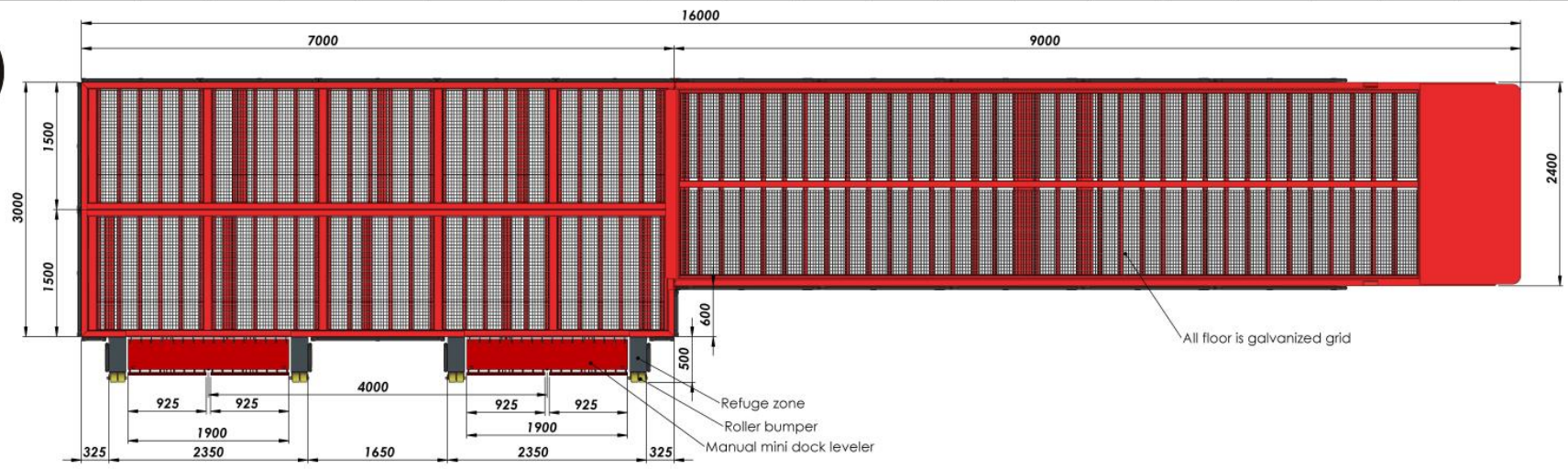

NAME - SURNAME	DATE	SIGN	QUANTITY	MASS (KG)	MATERIAL	PAGE NR
DRAWN BY: H. CANSEVER	19.10.2022		---			1/1
CONTROL: A. HEPBILDI	19.10.2022					
APPROVAL: S. ENTZMANN	19.10.2022					
SCALE: 1:100						
PART/ASSEMBLY NAME	DRAWING DESCRIPTION:		DRAWING NO.			
	#786B		---			



AZ MACHINERY - SLU, Matériels d'Élévation et Maintenance
 13 rue de la vallée - 66340 PALLATI DE CERDAGNE - France
 Téléphone : +33 (0) 37 48 300 - contact@az-machinery.com - www.az-machinery.com
 Site : 424 654 958 666 19 - TVA : FR02 824 654 958 - N° EORI : FR02 824 654 958

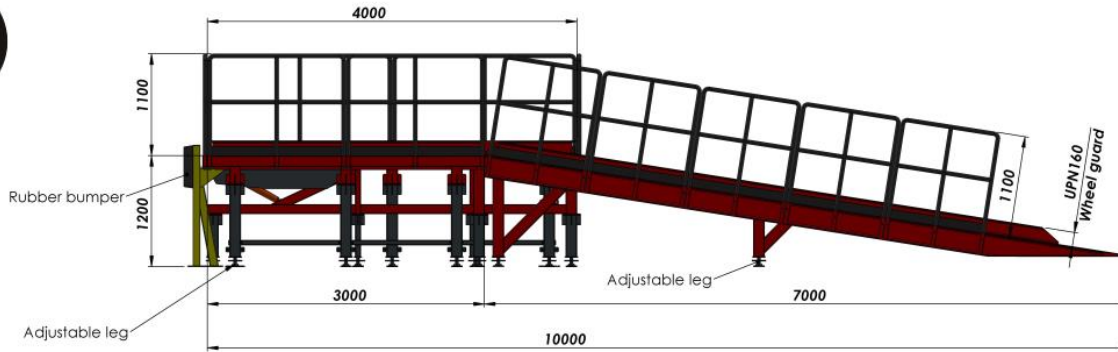

TELESCOPIC LIP DOCK LEVELER FEATURES

- CE Certificate
- Compatible design with EN 1398 and ANSI MH30.2
- Platform dimension: 2000x1576 mm
- Telescopic lip length: 500 mm
- Nominal working range + 450 / -420 cm
- Platform floor made of teardrop pattern plates
- Flap is made of strengthened teardrop pattern plates
- Heavy load capacity hinge system for maximum resistance to moving load
- Side protection plates conforming to safety standards
- Steel construction designed for load distribution
- Has a maintenance bar
- Maximum operating slope 12.5% (7°) for work and worker safety
- Working range: +300 / -300 mm
- 35 mm galvanized shafts,
- Flap 1 hydraulic piston works. (outer diameter min.50 mm, rod diameter 28 mm),
- Platform floor movement with double hydraulic pistons (outer diameter min.60mm, rod diameter 36mm),
- The mobility of the platform floor with the electro-hydraulic system,
- It has hydraulic emergency deceleration mechanism,
- Hydraulic unit Brevini
- Motor Voltage 3 Phase 380/400 V, 50 Hz, power at least 0.75 kW,
- It has a control panel that can control the system,
- Control panel has IP65 protection class,
- Solenoid coil lock to prevent the platform from going down when it is de-energized,
- -10/+40 operating temperature
- Rubber bumper mounted on ramp walls: 450 * 200 * 100 mm, 10 kg and 70 shore hardness,
- RAL 3002 and RAL 9005 color acrylic paint, cleaned with thinner before painting and painted with epoxy primer

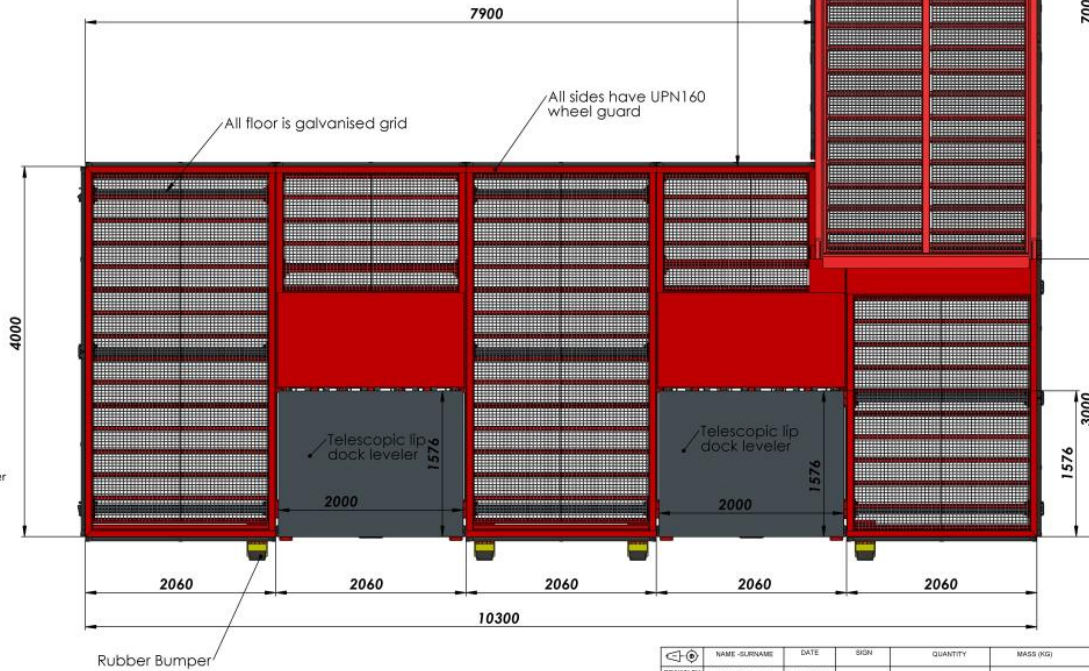

NAME - SURNAME	DATE	SIGN	QUANTITY	MASS (KG)	MATERIAL	PAGE NR
H. CANSEVER	11.01.2023		---			1/2
A. HEPBILDI	11.01.2023					
S. ENTZMANN	11.01.2023					
SCALE: 1:100						
PART/ASSEMBLY NAME			DRAWING DESCRIPTION		DRAWING NO.	
			#97UD		---	



AZ MACHINERY - SLU, Matériels d'Élévation et Maintenance
 13 rue de la source - 36300 PALAISEY DE CEDEX FRANCE
 Téléphone : +33 (0) 21 48 500 - contact@az-machinery.com - www.az-machinery.com
 Site : 424 654 958 660 FR - T.S.A. - FR02 424 654 958 - N° SIREN : FR02 424 654 958

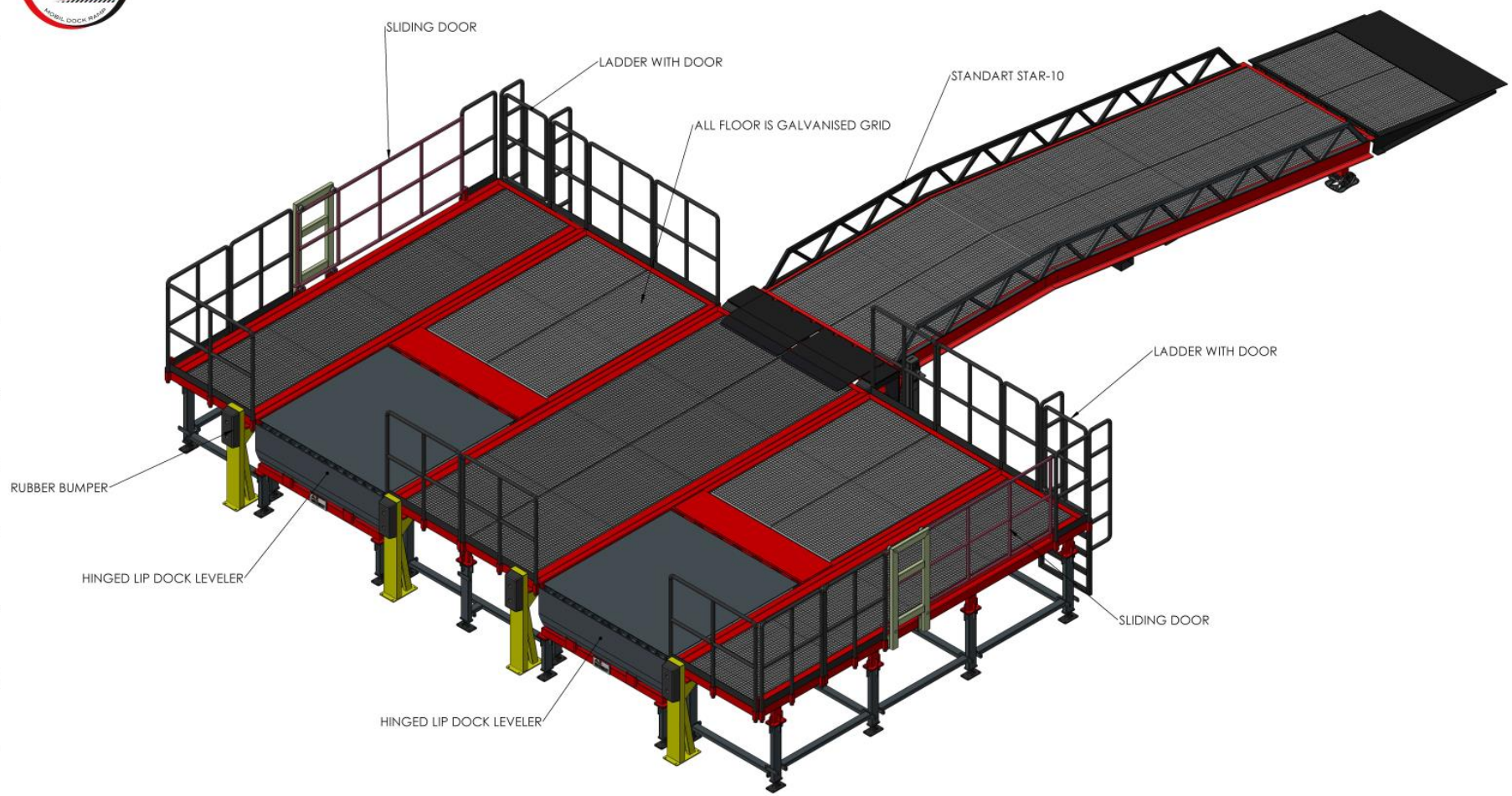

NAME - SURNAME	DATE	SIGN	QUANTITY	MASS (KG)	MATERIAL	PAGE NR
DRAWN BY: H. CANSEVER	23.08.2022		---			2/2
CONTROL: A. HEPBILDI	23.08.2022					
APPROVAL: S. ENTZMANN	23.08.2022					
SCALE: 1:100						
PART/ASSEMBLY NAME			DRAWING DESCRIPTION		DRAWING NO.	
			CUSTOMISED LOADING PLATFORM AZ_2287		---	



AZ MACHINERY - SLU, Matériels d'Élévation et Maintenance
 13 rue de la scierie - 66340 PALATRI DE CERDACHES - France
 Téléphone : +33 (0) 37 48 500 contact@az-machinery.com www.az-machinery.com
 Site : 424 654 958 666 19, TVA : FR02 824 654 958 - N° EORI : FR02 824 654 958

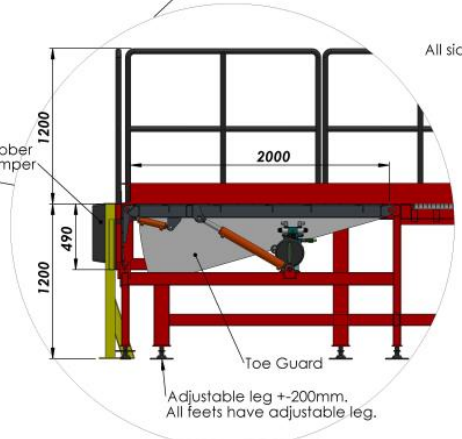
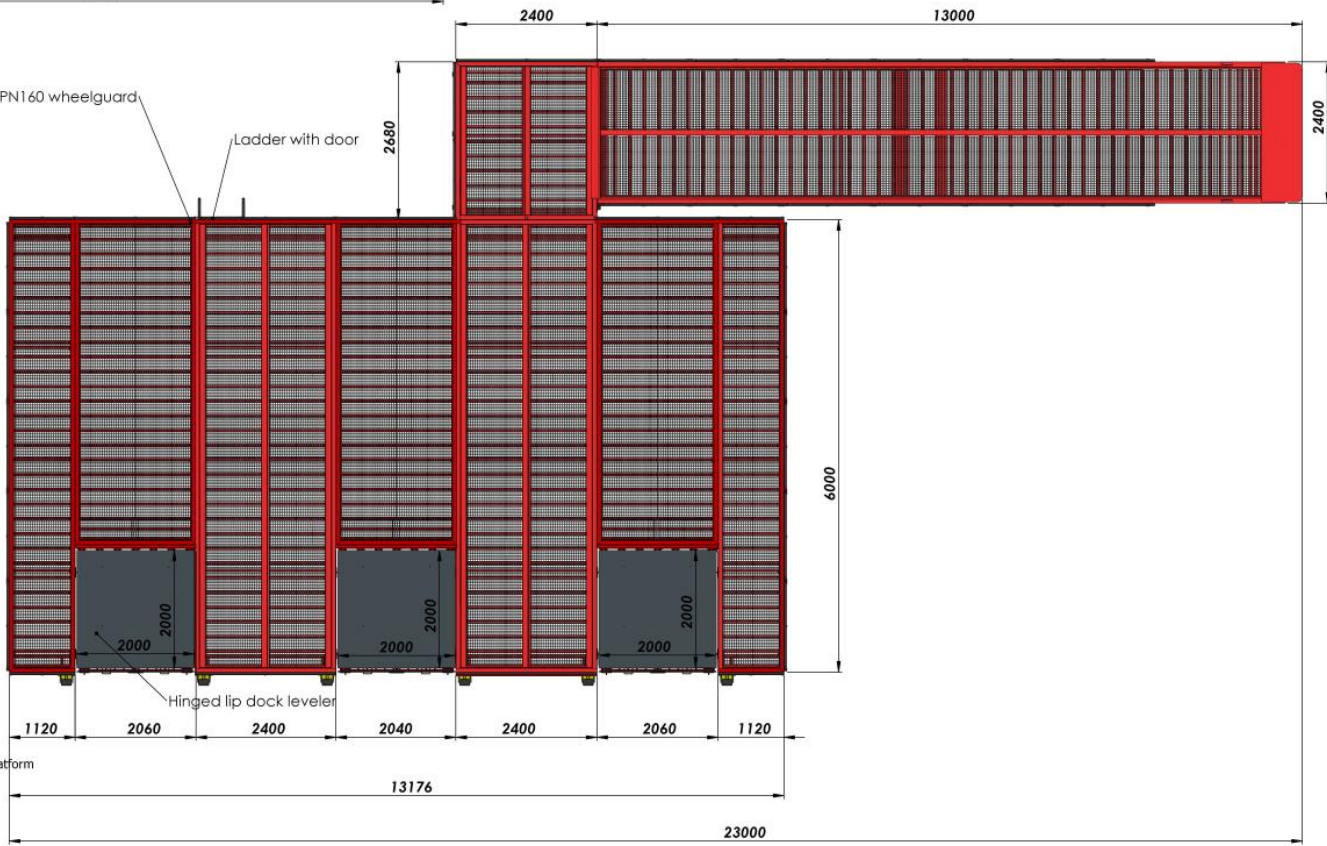
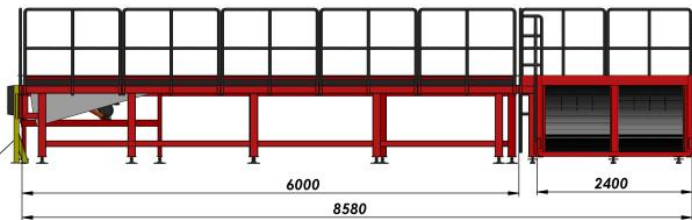

All sides have UPN160 wheelguard.
Ladder with door

HINGED LIP DOCK LEVELER FEATURES

1. Compliant with EUROPEAN STANDARD EN 1398 CE Certificate
2. Hinged wing consists of 12/13 mm sheet metal with tearing pattern
3. Easy to maintain, parts designed to be interchangeable,
4. Maximum working incline of 12.5% (7°)
5. There is a security lock,
6. It has galvanized side protection sheets in accordance with the safety standard,
7. There is a maintenance bar,
8. 2 pistons and hydraulic piston that moves the front tongue (movable lip) to lift the ramp platform
9. Nominal operating range + 380 / -250 mm
10. Sheet material and other steel materials used are made of St-37.2 material,
11. Steel construction designed for load distribution,
12. Flap 1 hydraulic piston works. (min.50 mm outer diameter, 28 mm bar diameter),
13. It has a hydraulic emergency deceleration mechanism,
14. -10/+40 operating temperature
15. Motor Voltage 3 Phase 230/400 V, 50 Hz, power at least 0.75 kW,
16. It has a control panel that can control the system,
17. Control panel has IP65 protection class,
18. Rubber bumper mounted on ramp walls: 450*200*100 mm, 10 kg and 70 Shore hardness,
19. Solenoid coil lock to prevent the platform from going down when the power is cut off,

NAME - SURNAME	DATE	SIGN	QUANTITY	MASS (KG)	MATERIAL	PAGE NR
DRAWN BY: H. CANSEVER	13.12.2022		---			1/2
CONTROL: A. HEPBILDI	13.12.2022					
APPROVAL: S. ENTZMANN	13.12.2022					
SCALE: 1:200						
PART/ASSEMBLY NAME		DRAWING DESCRIPTION		DRAWING NO.		
		#2RH0 EVONIK		---		



AZ MACHINERY - SLU, Matériels d'Élévation et Maintenance
13 rue de la machine - 46300 PALLATI DE CHERBOURG - France
Téléphone : +33 (0) 27 48 500 - contact@az-machinery.com - www.az-machinery.com
Site : 424 654 958 666 14 - TVA : FR02 824 654 958 - N° EORI : FR02 824 654 958

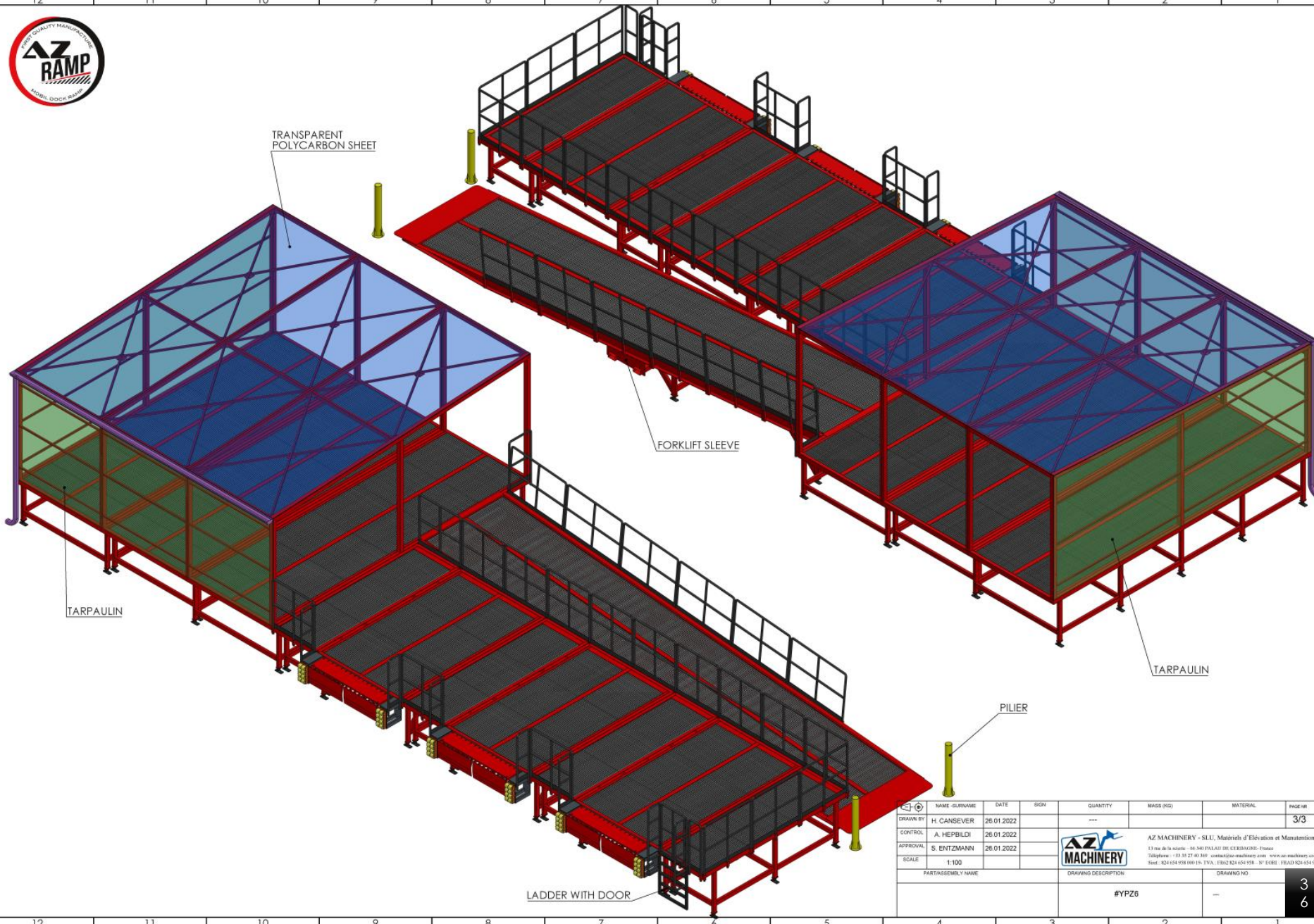

NAME - SURNAME	DATE	SIGN	QUANTITY	MASS (KG)	MATERIAL	PAGE/NT
DRAWN BY: H. CANSEVER	26.01.2022		---			3/3
CONTROL: A. HEPBILDI	26.01.2022					
APPROVAL: S. ENTZMANN	26.01.2022					
SCALE: 1:100						
PART/ASSEMBLY NAME	DRAWING DESCRIPTION:		DRAWING NO.			
	#YPZ6		---			



AZ MACHINERY - SLU, Matériels d'Élévation et Manutention
 13 rue de la machine - 3630 PALAIS DE CERDACHES - France
 Téléphone : +33 (0) 27 48 500 - contact@az-machinery.com - www.az-machinery.com
 Site : 824 654 958 666 19 - TVA : FR02 824 654 958 - 3° ED081 - FR02 824 654 958

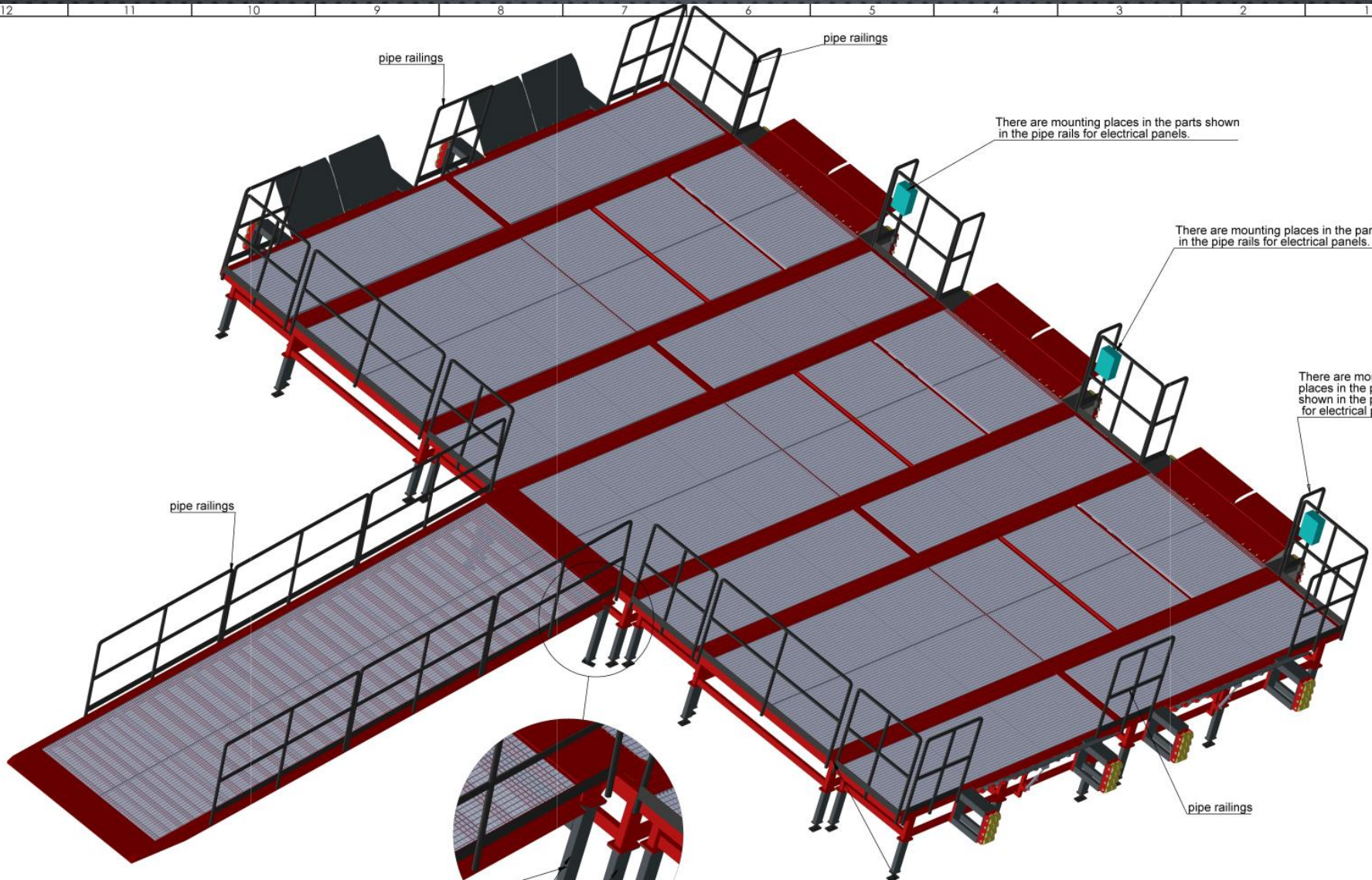

pipe railings

pipe railings

There are mounting places in the parts shown in the pipe rails for electrical panels.

There are mounting places in the parts shown in the pipe rails for electrical panels.

There are mounting places in the parts shown in the pipe rails for electrical panels.

pipe railings

pipe railings

only the feet of the ramp are different and packaged accordingly.

Each platform have connection flange.

platform ramp feet are different.
The way the flanges are connected is the same as the platform.

All legs are same.
First, the legs must be attached to the platforms.
After adjustment, the flange of the feet should be fixed to the concrete foundation.

NAME-SURNAME	DATE	SIGN	QUANTITY	MASS (KG)	MATERIAL	PAGE/NO
H.CANSEVER	01.06.22		---			1/1
CONTROL	A.HEPBILDI	01.06.22				
APPROVAL	S.ENTZMANN	01.06.22				
SCALE	1:100					
PART/ASSEMBLY NAME			DRAWING DESCRIPTION			DRAWING NO.
			#EİBB			---

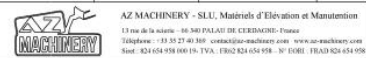



DRAWINGS

Rampes mobiles

Rampes fixes

Plateformes logistiques

Rampes de quai

Réhausse

Tables de quai mobiles

Tables de quai fixes

Passerelles

Rampes pour conteneurs

Niveleurs

Fournitures de quai

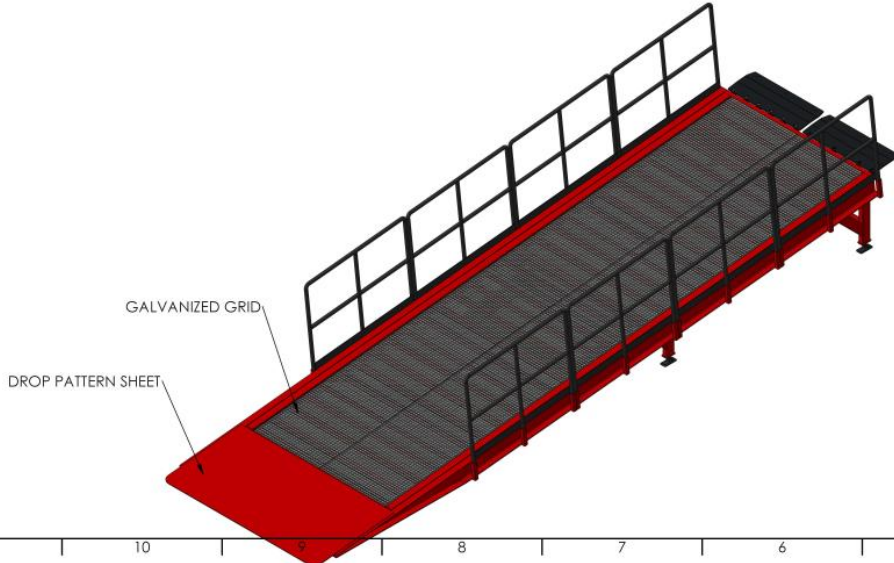
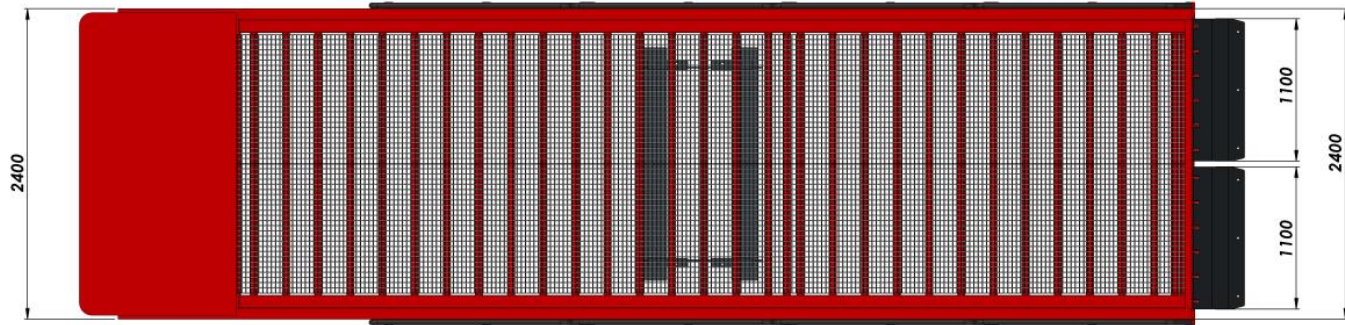
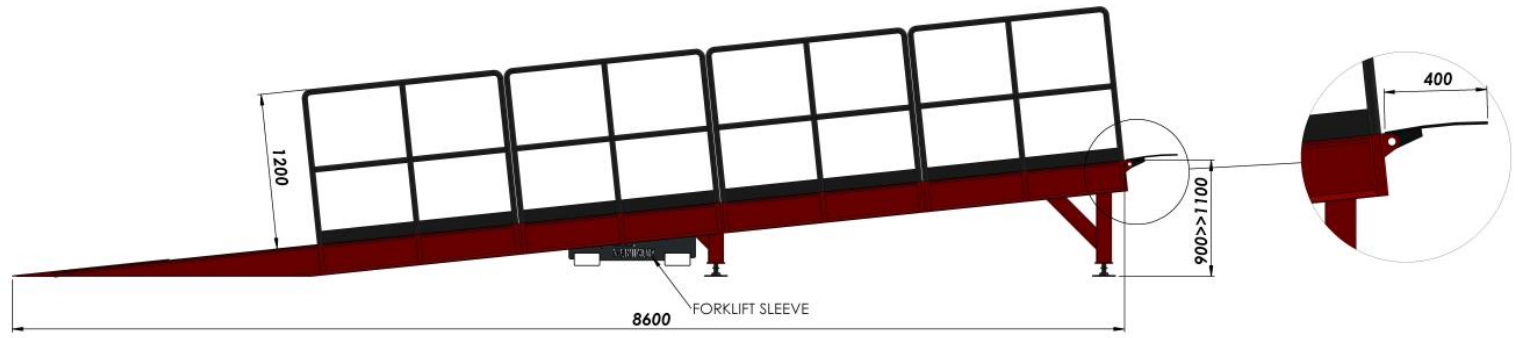

CAPACITY: 4000 KG

NAME - SURNAME	DATE	SIGN	QUANTITY	MASS (KG)	MATERIAL	PAGE NR
DRAWN BY: H. CANSEVER	22.06.2022		---			1/2
CONTROL: A. HEPBILDI	22.06.2022					
APPROVAL: S. ENTZMANN	22.06.2022					
SCALE: 1:50						
PART/ASSEMBLY NAME	DRAWING DESCRIPTION:		DRAWING NO.			
	#4RJL		---			



AZ MACHINERY - SLU, Matériels d'Élévation et Maintenance
 13 rue de la mairie - 86 540 PALLATI DE CEZEMANS - France
 Téléphone : +33 (0) 27 48 500 - contact@az-machinery.com - www.az-machinery.com
 Site : 824 654 958 000 FR - TVA : FR02 824 654 958 - 3° EORL - FR02 824 654 958

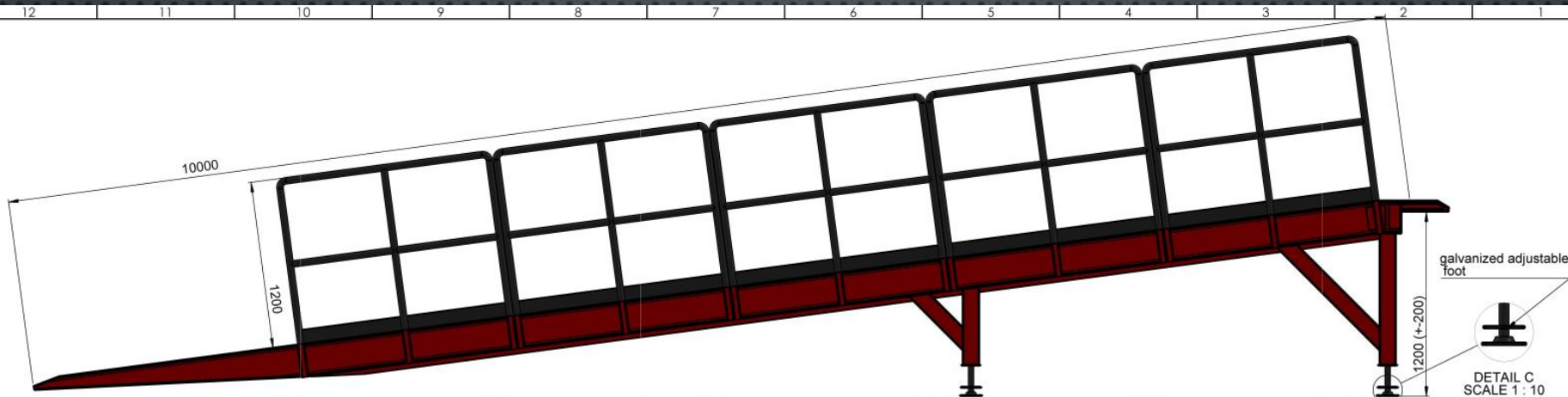

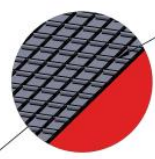
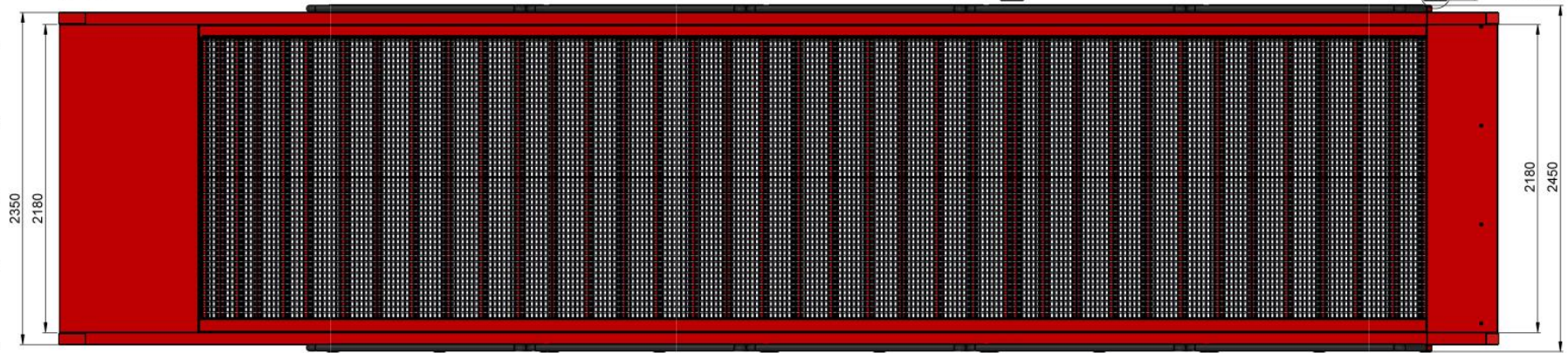

DETAIL C
SCALE 1 : 10

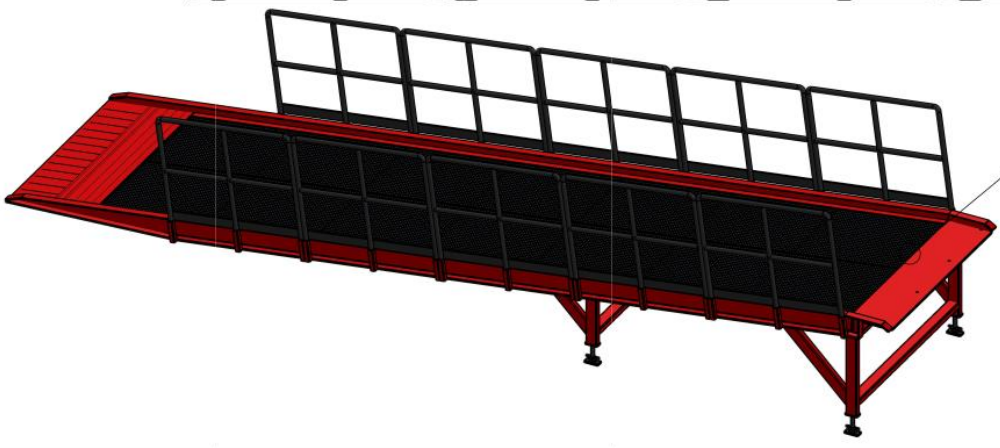

galvanized grid

DETAIL B
SCALE 1 : 5



NAME	SURNAME	DATE	SIGN	QUANTITY	MASS (KG)	MATERIAL	PAGE/NB
B	OZC/FCI	12.04.22		---			1/1
 AZ MACHINERY - SLU, Matériels d'Élévation et Maintenance <small>13 rue de la source - 86 540 PALAIS DE CÉRÉALES - FRANCE Téléphone : +33 (0) 27 48 380 - contact@az-machinery.com - www.az-machinery.com Site : 824 654 958 000 FR - TVA : FR02 824 654 958 - 3^e EOEI - FRAD 824 654 958</small>							
PARTASSEMBLY NAME				DRAWING DESCRIPTION		DRAWING NO.	
#PB7C				---		---	

4
0

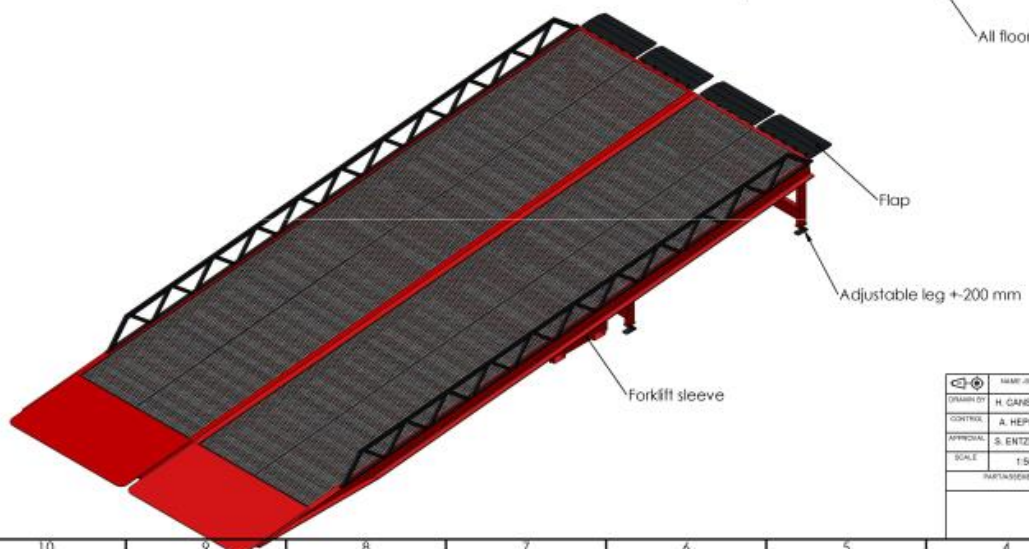
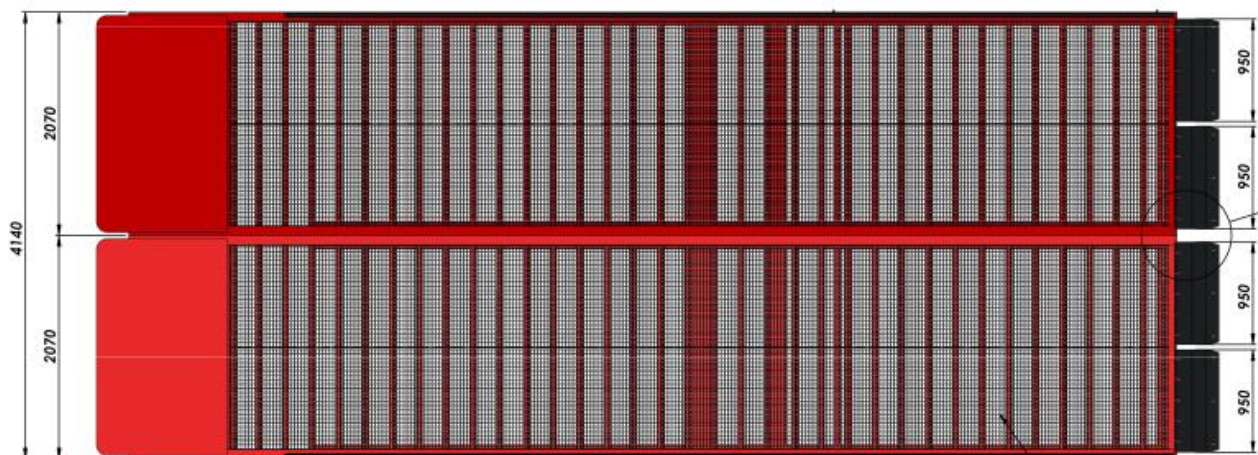
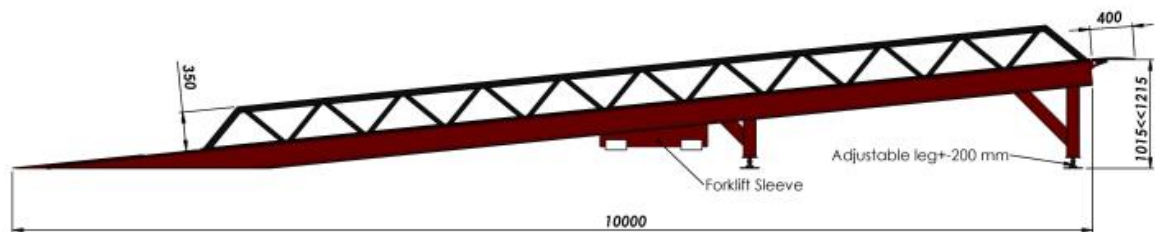

NO.	NAME (SURNAME)	DATE	ISSN	QUANTITY	MARKING	MATERIAL	PRICE (€)
01	H. CARREVER	24.10.2022		1			1/2
02	A. HEPBLDI	24.10.2022					
03	S. ENTZMANN	24.10.2022					
PARTS/DESCRIPTION				DRAWING DESCRIPTION		DRAWING NO.	
				#9396		...	



AZ MACHINERY - S.p.A. Materials of Education and Manufacturing
 17 rue de la Grande - 46100 PALLAS (Lot 17) FRANCE
 Téléphone : +33 (0) 57 82 50 00 - contact@az-machinery.com - www.az-machinery.com
 Fax : +33 (0) 57 82 50 01 - 17, rue de la Grande - 46100 PALLAS - FRANCE

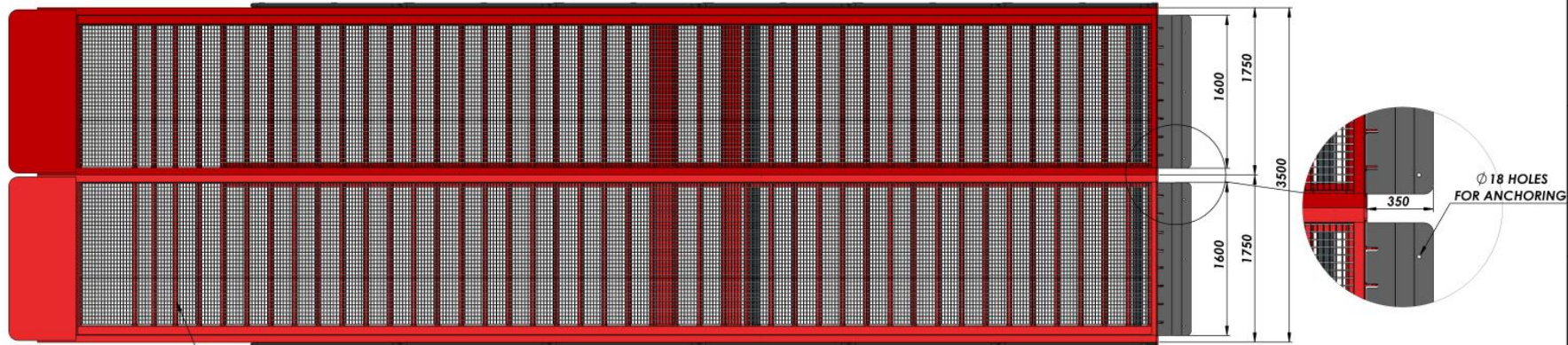
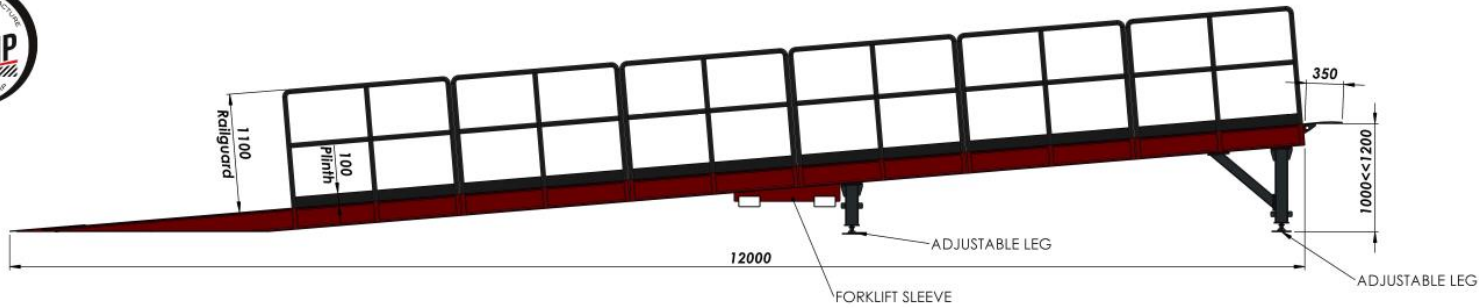

ALL FLOOR IS GALVANISED GRID

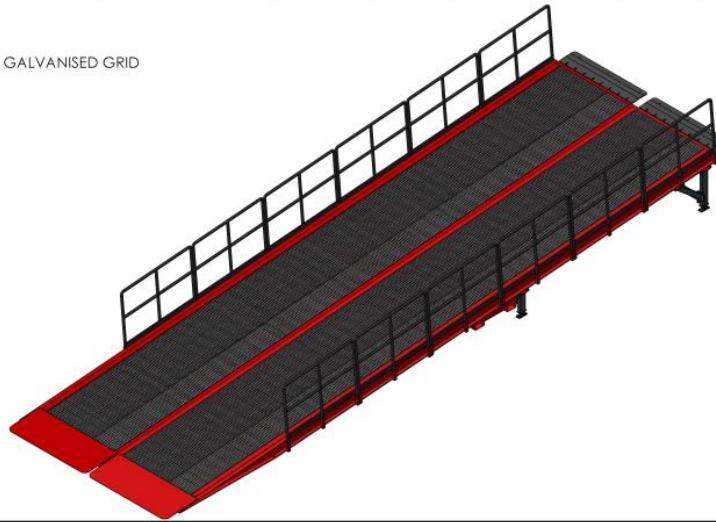

NAME - SURNAME	DATE	SIGN	QUANTITY	MASS (KG)	MATERIAL	PAGE/MT
DRAWN BY H. CANSEVER	23.09.2022		---			1/2
CONTROL A. HEPBILDI	23.09.2022					
APPROVAL S. ENTZMANN	23.09.2022					
SCALE 1:50						
PART/ASSEMBLY NAME	DRAWING DESCRIPTION		DRAWING NO.			
	#60EG		---			



AZ MACHINERY - SLU, Matériels d'Élévation et Maintenance
 13 rue de la source - 46 340 PULVILLIÈRE (CERANNOIS) - France
 Téléphone : +33 (0) 27 48 500 - contact@az-machinery.com - www.az-machinery.com
 Site : 424 654 958 000 FR - TVA : FR02 824 654 958 - N° EORI : FR02 824 654 958

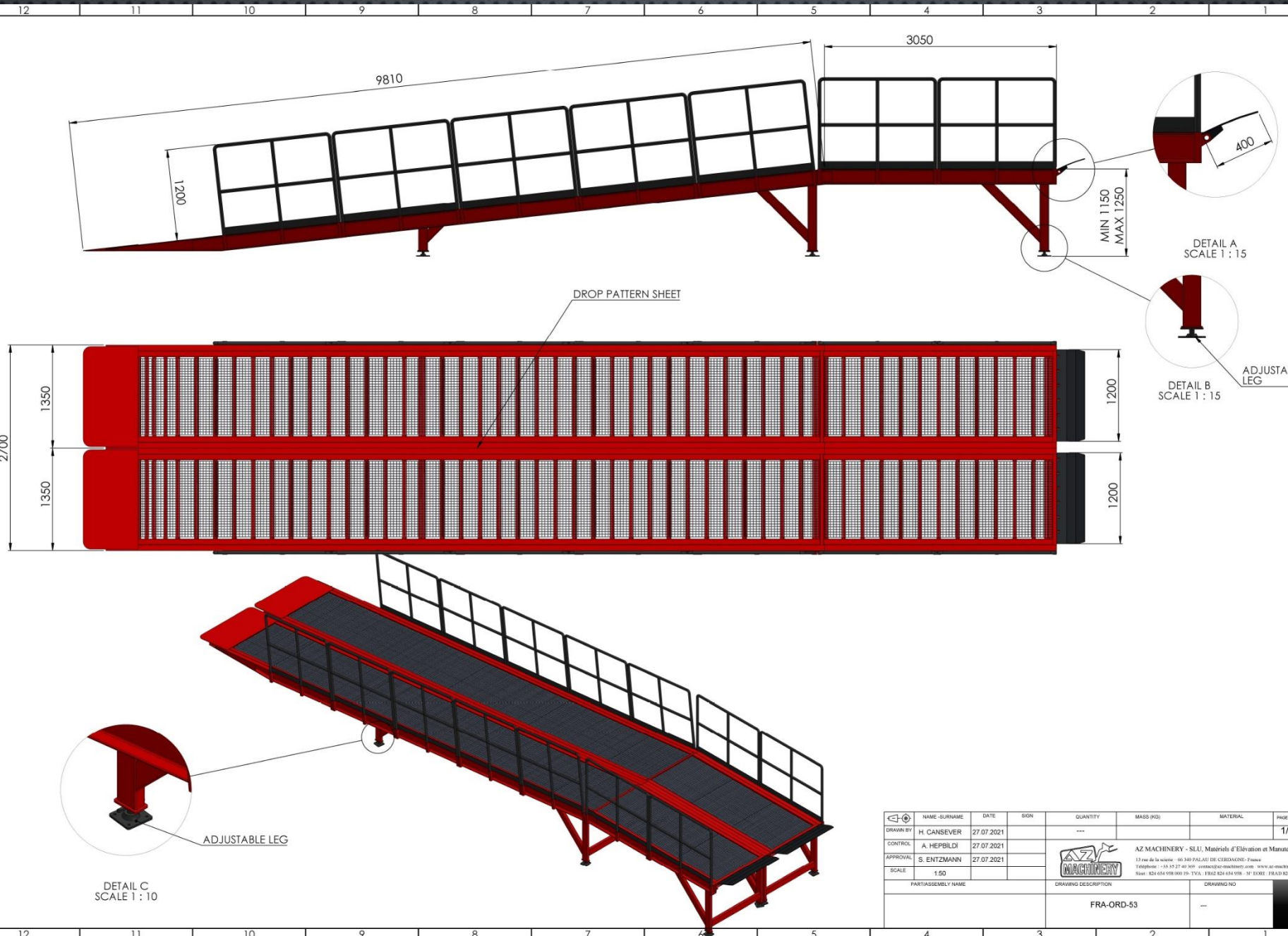

NAME-SURNAME	DATE	SIGN	QUANTITY	MASS (KG)	MATERIAL	PAGE NR
DRAWN BY H. CANSEVER	27.07.2021		---			1/1
CONTROL A. HEPBILDI	27.07.2021					
APPROVAL S. ENTZMANN	27.07.2021					
SCALE 1:50						
PART/ASSEMBLY NAME		DRAWING DESCRIPTION		DRAWING NO		
		FRA-ORD-53		---		



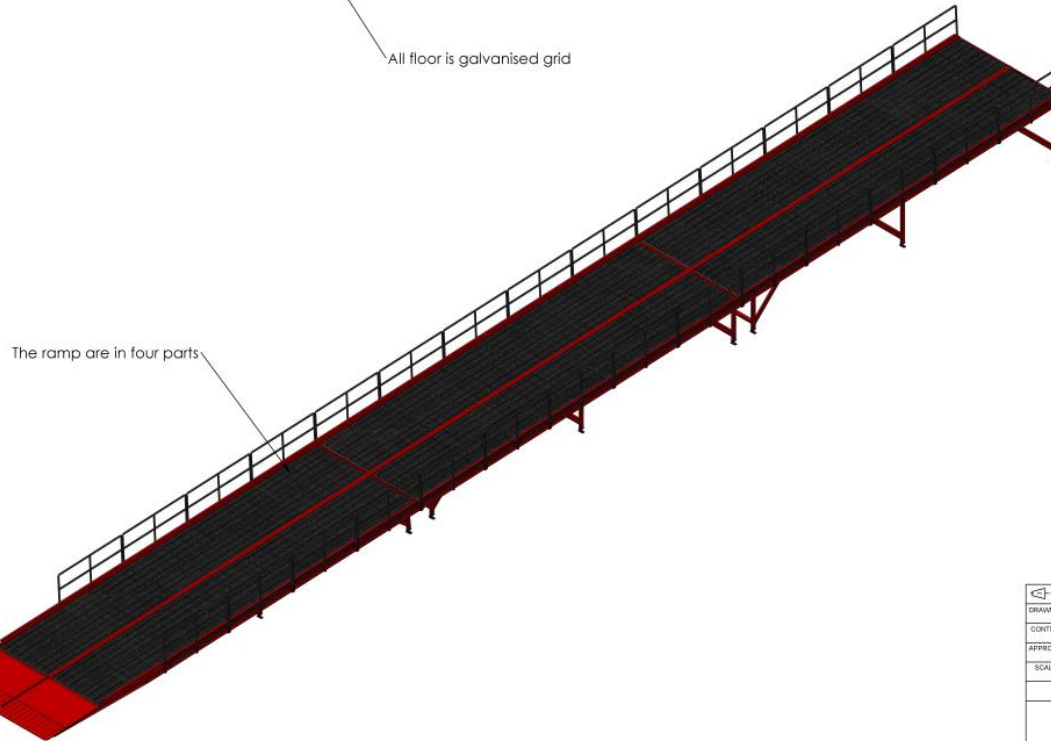
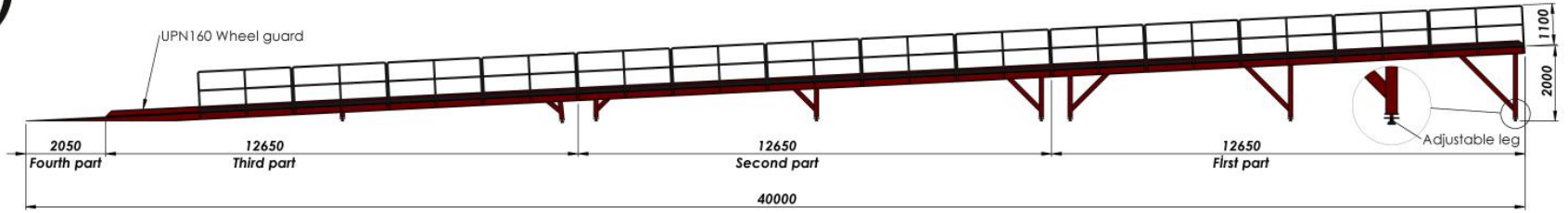

NAME - SURNAME	DATE	SIGN	QUANTITY	MASS (KG)	MATERIAL	PAGE NR
DRAWN BY H. CANSEVER	02.02.2023		---			1/2
CONTROL A. HEPBILDI	02.02.2023					
APPROVAL S. ENTZMANN	02.02.2023					
SCALE 1:200						
PART/ASSEMBLY NAME			DRAWING DESCRIPTION		DRAWING NO.	
			#Y4AS		---	



AZ MACHINERY - SLU, Matériels d'Élévation et Maintenance
 13 rue de la scierie - 86 340 PALAIS DE CÉRÉBIENS - France
 Téléphone : +33 (0) 27 48 300 - contact@az-machinery.com - www.az-machinery.com
 Site : 824 654 958 000 FR - TVA : FR02 824 654 958 - N° EORI : FR02 824 654 958

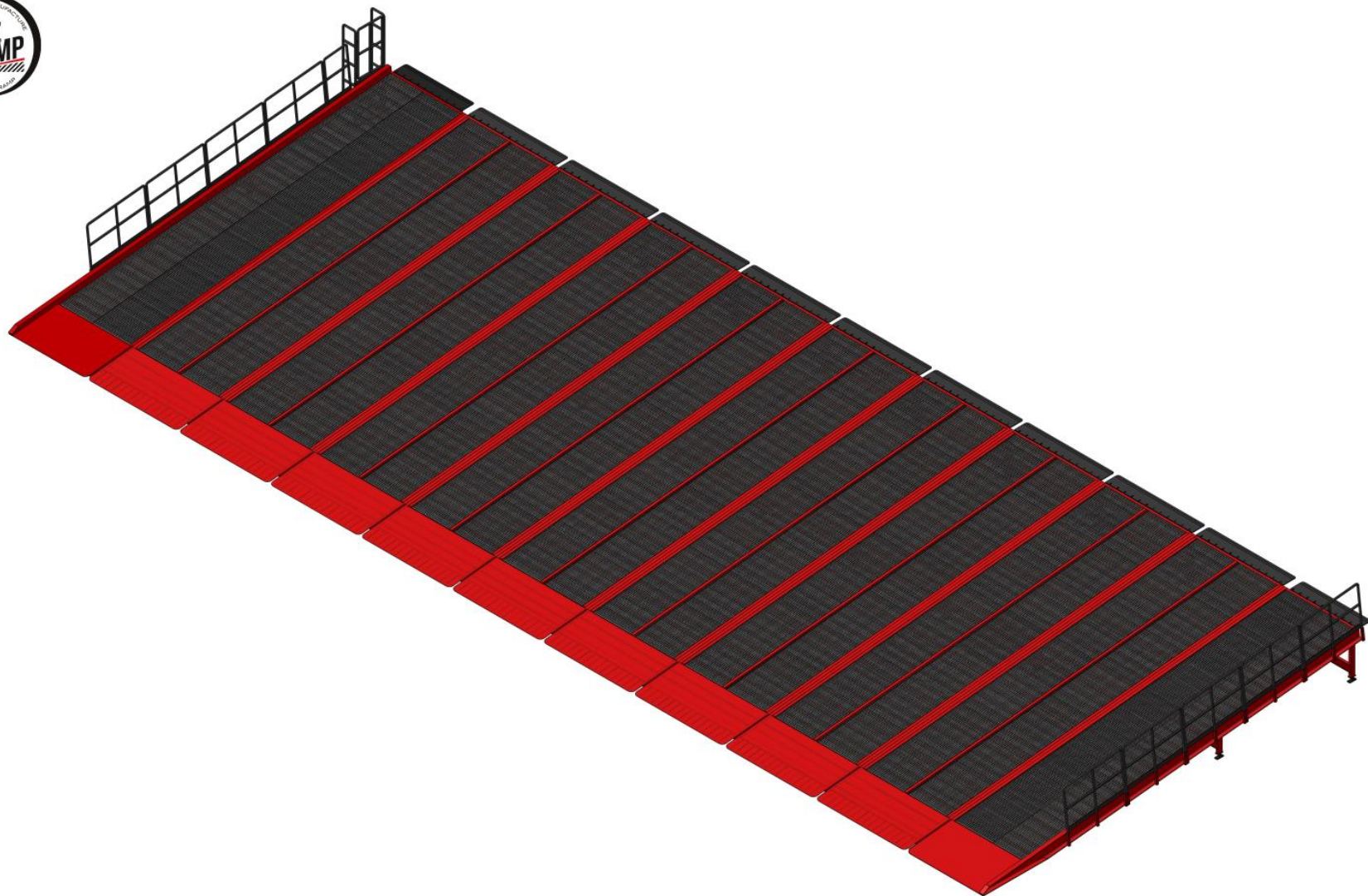

NAME - SURNAME	DATE	SIGN	QUANTITY	MASS (KG)	MATERIAL	PAGE NR
DRAWN BY H. CANSEVER	05.10.2022		---			2/2
CONTROL A. HEPBILDI	05.10.2022					
APPROVAL S. ENTZMANN	05.10.2022					
SCALE 1:50						
PART/ASSEMBLY NAME			DRAWING DESCRIPTION		DRAWING NO.	
			#NC32		---	



AZ MACHINERY - SLU, Matériels d'Élévation et Maintenance
 13 rue de la machine - 16 540 PALLAT DE CEBRANNOIS - France
 Téléphone : +33 (0) 37 48 500 - contact@az-machinery.com - www.az-machinery.com
 Site : 824 654 958 000 FR - TVA : FR02 824 654 958 - 3^e E0001 - REAO 824 654 958

4
5

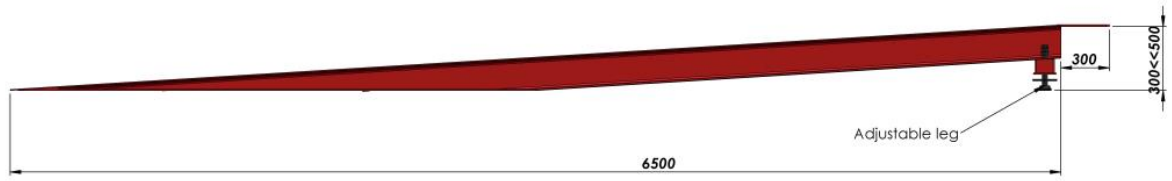

All floor is drop pattern sheet.

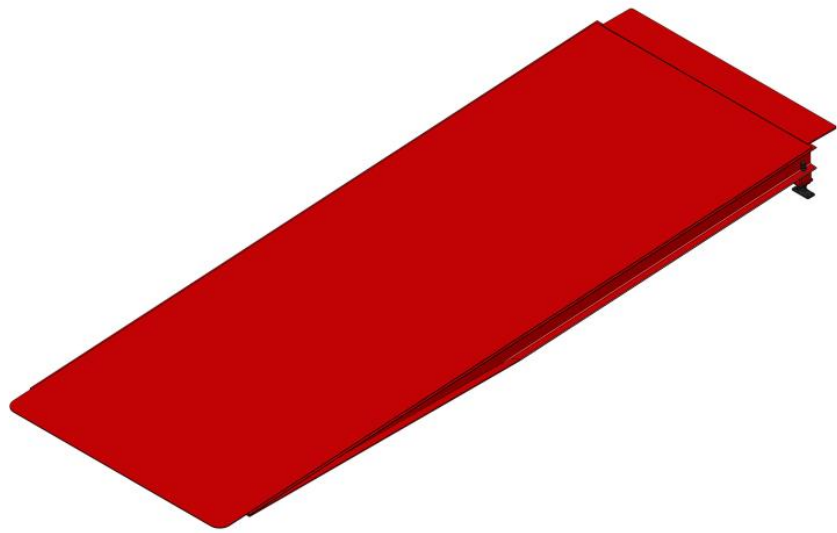

CAPACITY: 12000 KG

NAME - SURNAME	DATE	SIGN	QUANTITY	MASS (KG)	MATERIAL	PAGE NR
DRAWN BY: H. CANSEVER	09.02.2023		---			1/1
CONTROL: A. HEPBILDI	09.02.2023					
APPROVAL: S. ENTZMANN	09.02.2023					
SCALE: 1:50						
PART/ASSEMBLY NAME			DRAWING DESCRIPTION		DRAWING NO.	
			#7MR6		---	



AZ MACHINERY - SLU, Matériels d'Élévation et Maintenance
 13 rue de la scierie - 86 340 PALLAS DE CEEBAKERS - France
 Téléphone : +33 (0) 37 48 300 - contact@az-machinery.com - www.az-machinery.com
 Site : 824 654 958 000 FR - TVA : FR02 824 654 958 - 3° E0001 - FR02 824 654 958

4
6



DRAWINGS

Rampes mobiles

Rampes fixes

Plateformes logistiques

Rampes de quai

Réhausse

Tables de quai mobiles

Tables de quai fixes

Passerelles

Rampes pour conteneurs

Niveleurs

Fournitures de quai

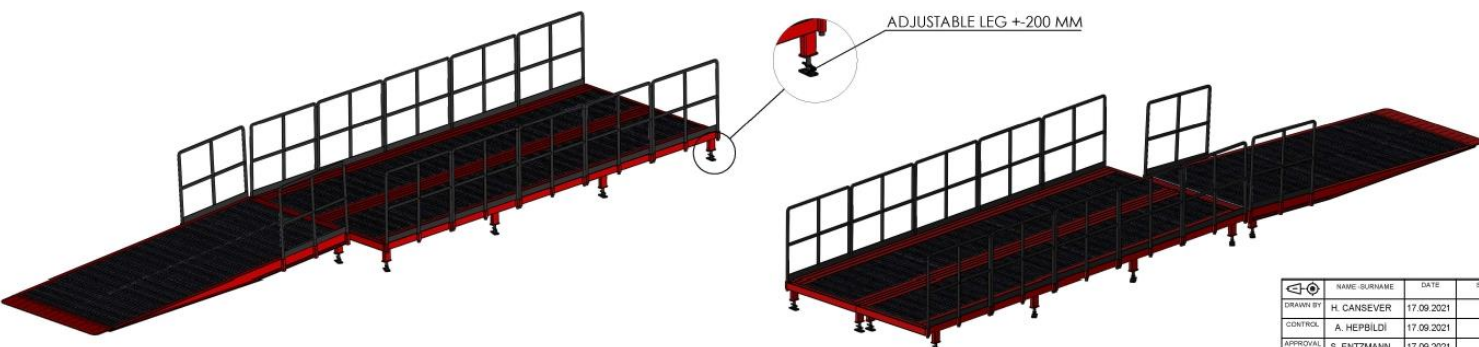
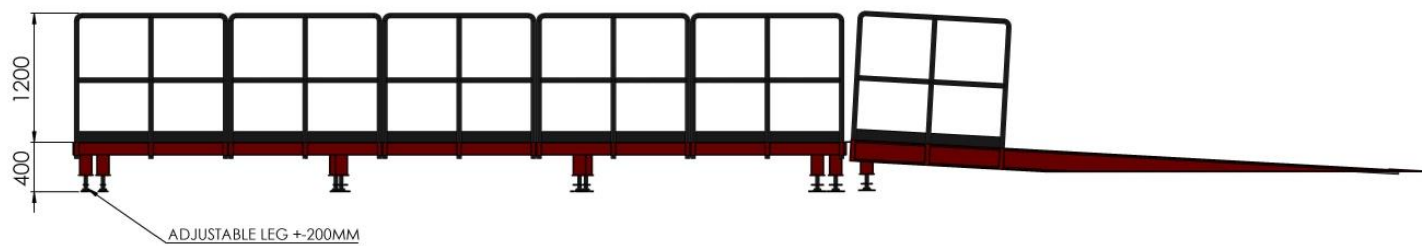
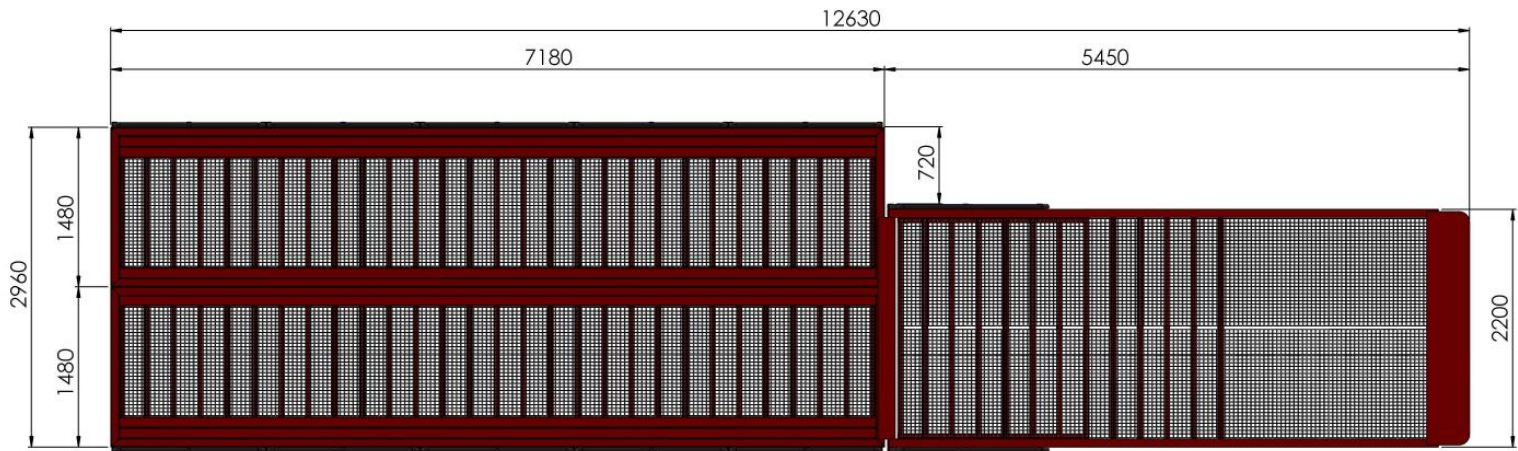

NAME-SURNAME	DATE	IGN	QUANTITY	MASS (KG)	MATERIAL	PAGE NR
DRAWN BY H. CANSEVER	17.09.2021		---			1/1
CONTROL A. HEPBILDI	17.09.2021					
APPROVAL S. ENTZMANN	17.09.2021					
SCALE 1:50						
PART/ASSEMBLY NAME			DRAWING DESCRIPTION			DRAWING NO.
			#E7BG LOW DOCK FRA-ORD-62			---



AZ MACHINERY - S.L.U. Matériels d'Élévation et Manutention
 13 rue de la source - 69 340 PALLAT - DE CEREDAINE - France
 Téléphone : +33 (0) 47 42 90 00 - contact@azmachinery.com - www.azmachinery.com
 Siret : 824 054 018 000 13-15-A - FRAD 824 054 018 - N° ECE01 - FRAD 824 054 018

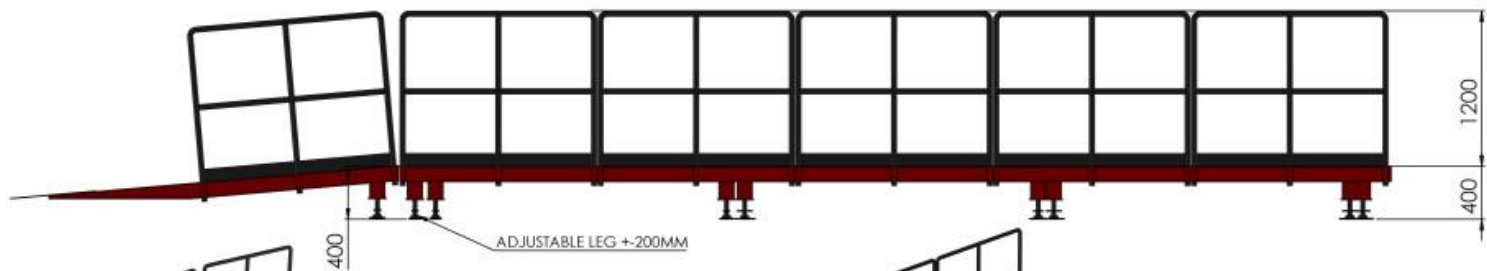
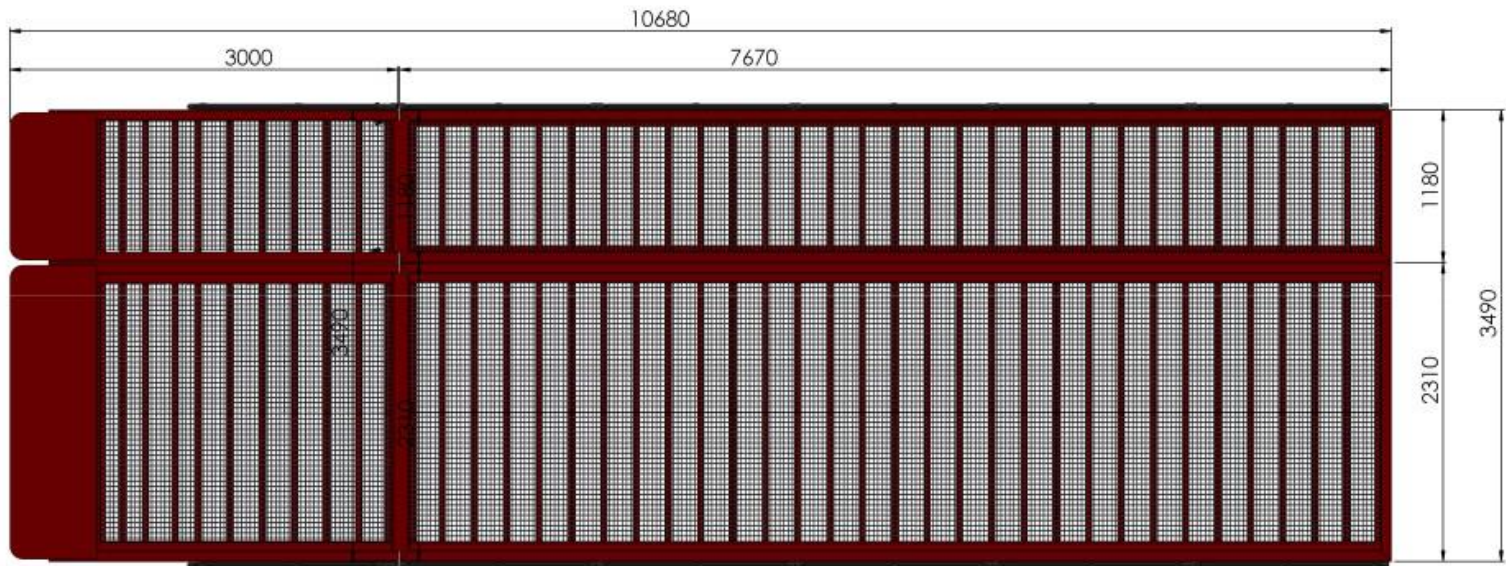

NO.	NAME (Uppr.)	DATE	ISSUE	QUANTITY	BASE NO.	MATERIAL	PROG. NO.
01	H. CARBEVER	17.09.2021					1/1
02	A. HEPBLD	17.09.2021					
03	S. ENTZMANN	17.09.2021					
04							
05							
PARTS LIST			DRAWING DESCRIPTION		DRAWING NO.		
			#E7BG LOW DOCK, REV01 FRA-ORD-62		-		

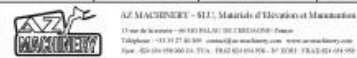



GALVANIZED GRID

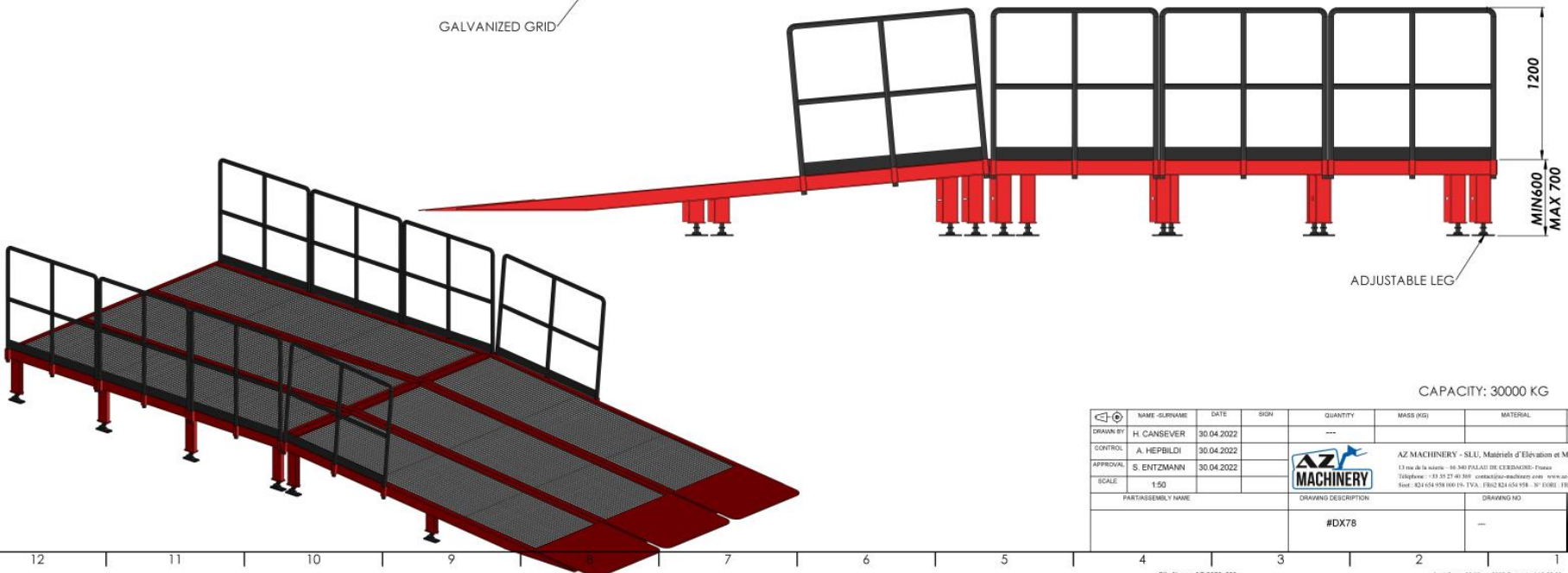

ADJUSTABLE LEG

CAPACITY: 30000 KG

NAME	SURNAME	DATE	SIGN	QUANTITY	MASS (KG)	MATERIAL	PAGE/NT
DRAWN BY	H. CANSEVER	30.04.2022		---			1/1
CONTROL	A. HEPBILDI	30.04.2022					
APPROVAL	S. ENTZMANN	30.04.2022					
SCALE	1:50						
PART/ASSEMBLY NAME				DRAWING DESCRIPTION		DRAWING NO.	
				#DX78		---	



AZ MACHINERY - SLU, Matériels d'Élévation et Maintenance
 13 rue de la source - 46 340 PUYLASSI DE CEBRANNOIS - France
 Téléphone : +33 (0) 37 46 300 - contact@az-machinery.com - www.az-machinery.com
 Site : 424 654 958 000 FR - TVA : FR02 824 654 958 - 3^e EORL - FR02 824 654 958

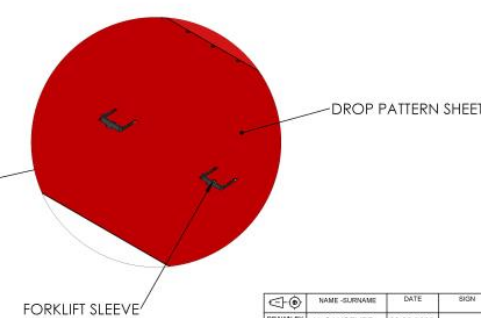
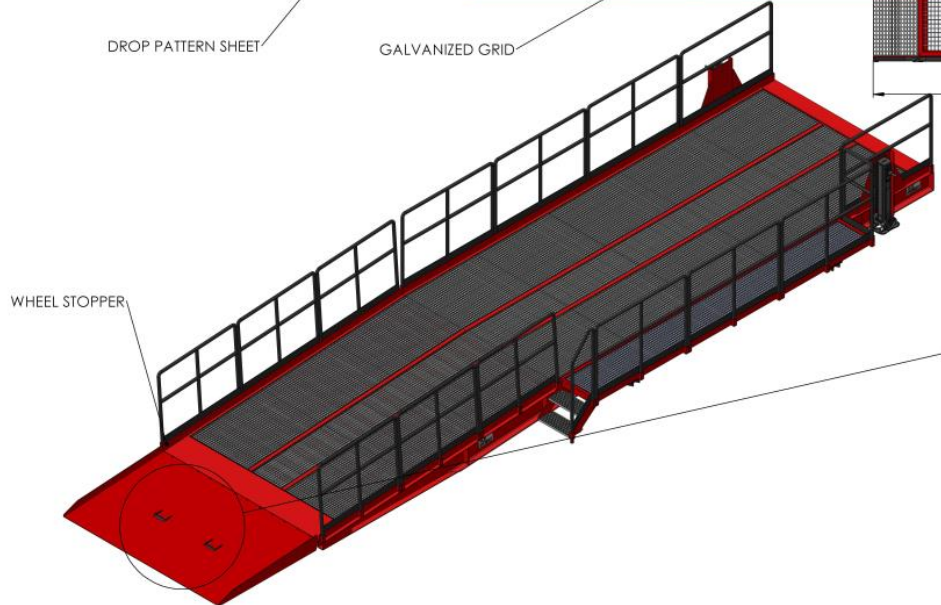
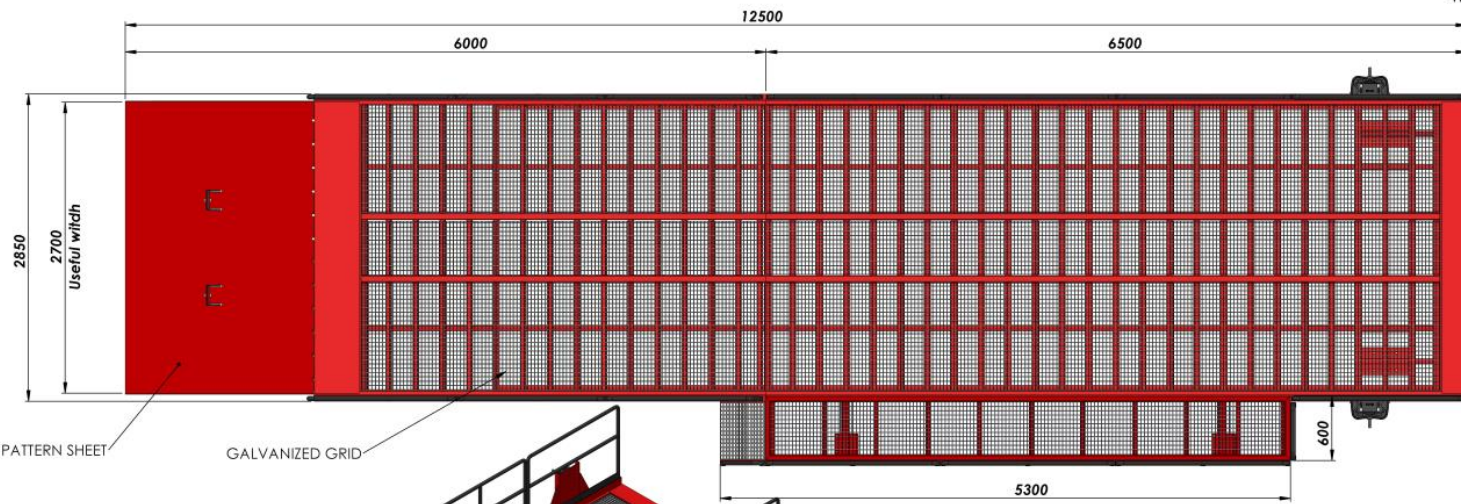
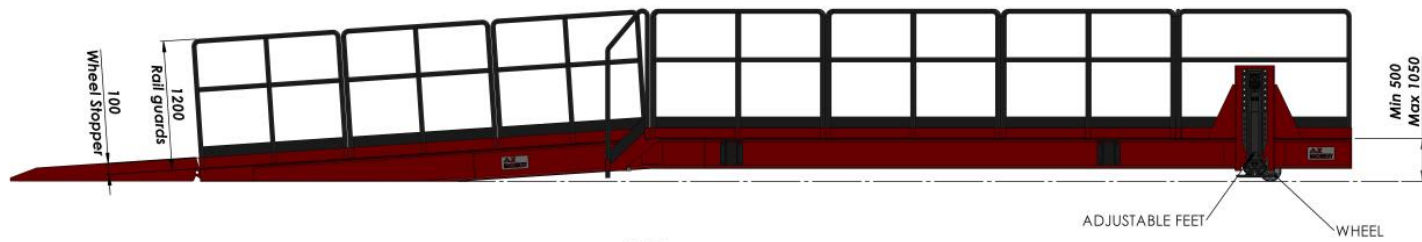

CAPACITY: 12000 KG

NAME - SURNAME	DATE	SIGN	QUANTITY	MASS (KG)	MATERIAL	PAGE NR
DRAWN BY: H. CANSEVER	08.08.2022		---			1/2
CONTROL: A. HEPBILDI	08.08.2022					
APPROVAL: S. ENTZMANN	08.08.2022					
SCALE: 1:50						
PART/ASSEMBLY NAME	DRAWING DESCRIPTION:		DRAWING NO.			
	CUSTOMISED LOW DOCK		---			



AZ MACHINERY - SLU, Matériels d'Élévation et Maintenance
 13 rue de la source - 46 540 PÉLASSI DE CÉBERACROT - France
 Téléphone : +33 (0) 37 48 500 - contact@az-machinery.com - www.az-machinery.com
 Site : 424 654 958 000 FR - TVA : FR02 824 654 958 - 3^e EORL - FR02 824 654 958

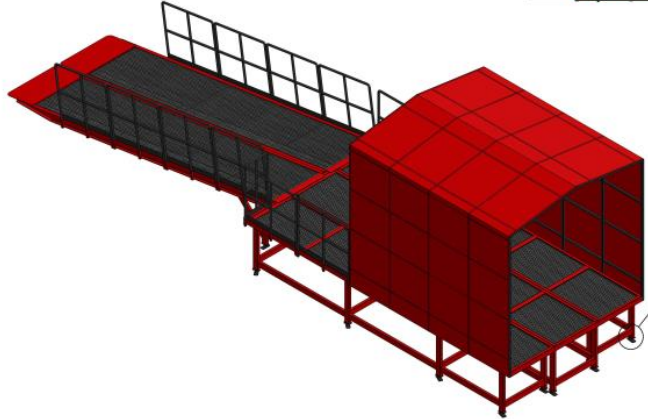
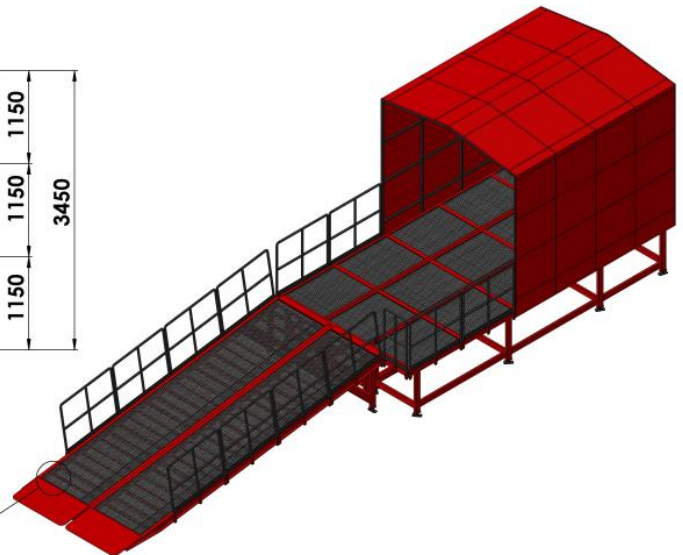
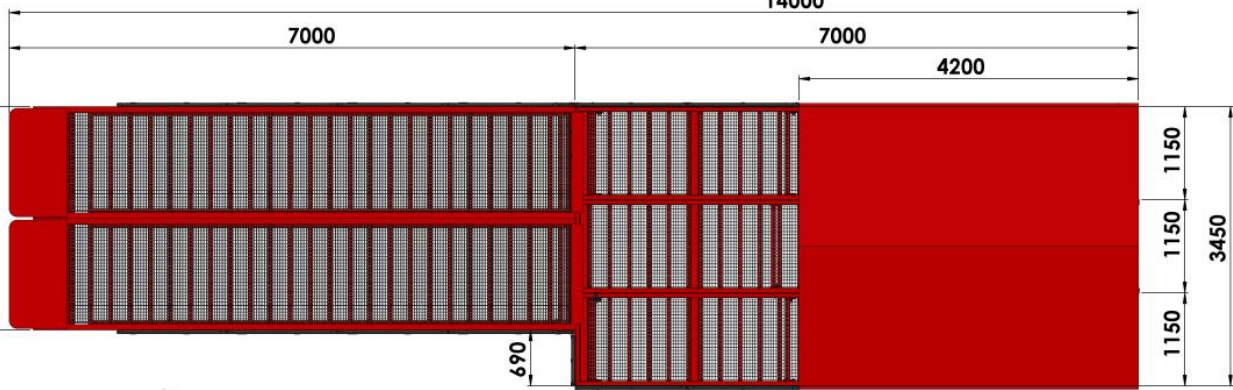
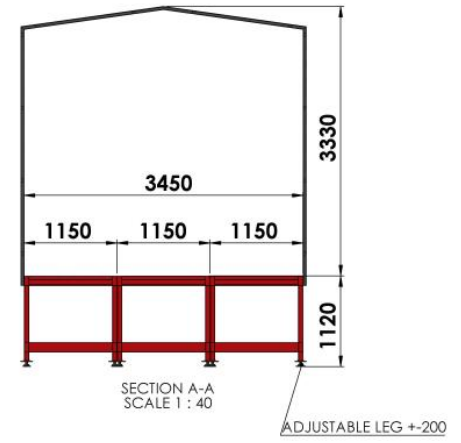
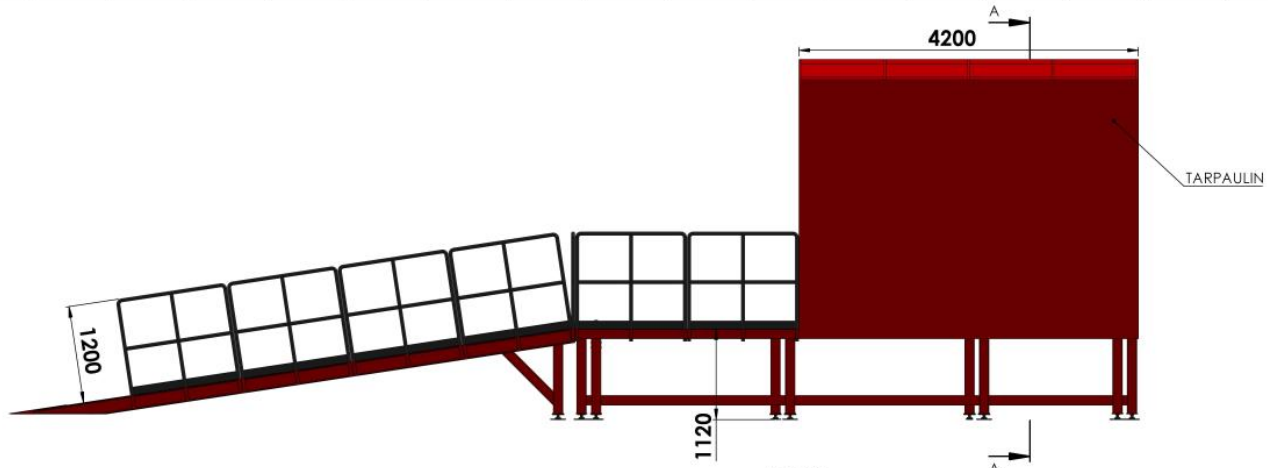

ADJUSTABLE LEG WITH FLANGE

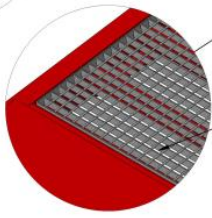

GALVANIZED GRID

NAME - SURNAME	DATE	SIGN	QUANTITY	MASS (KG)	MATERIAL	PAGE NR
DRAWN BY: H. CANSEVER	14.10.2021		---			1/1
CONTROL: A. HEPBILDI	14.10.2021					
APPROVAL: S. ENTZMANN	14.10.2021					
SCALE: 1:100						
PART/ASSEMBLY NAME	DRAWING DESCRIPTION:		DRAWING NO.			
	#E2CD		---			



AZ MACHINERY - SLU, Matériels d'Élévation et Manutention
 13 rue de la source - 36 340 PALATY DE CERDACHON - France
 Téléphone : +33 (0) 27 48 500 - contact@az-machinery.com - www.az-machinery.com
 Site : 824 654 958 666 FR - TVA : FR02 824 654 958 - N° EORI : FR02 824 654 958

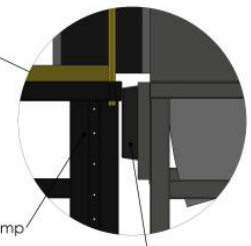
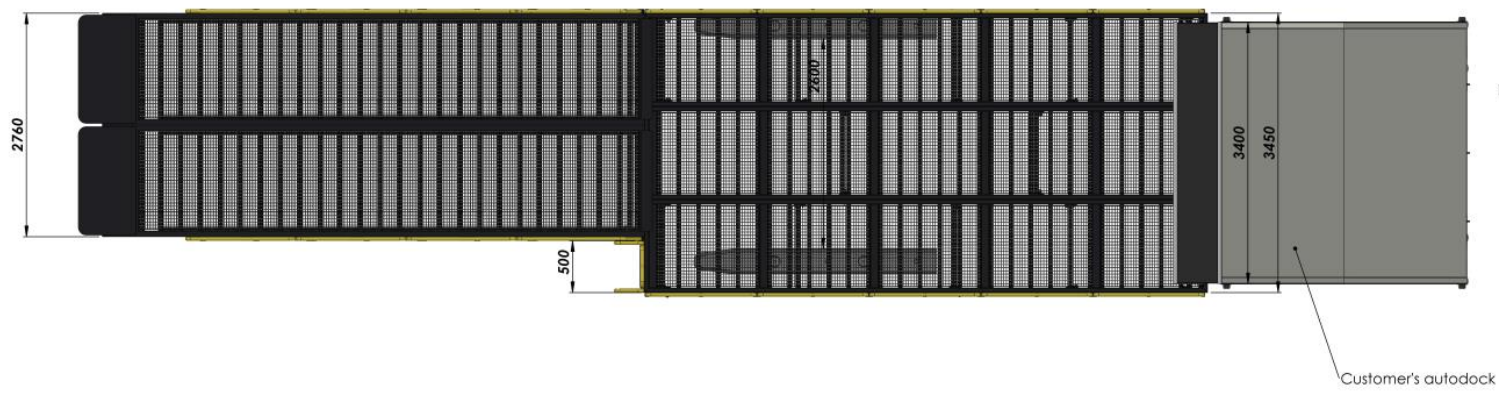
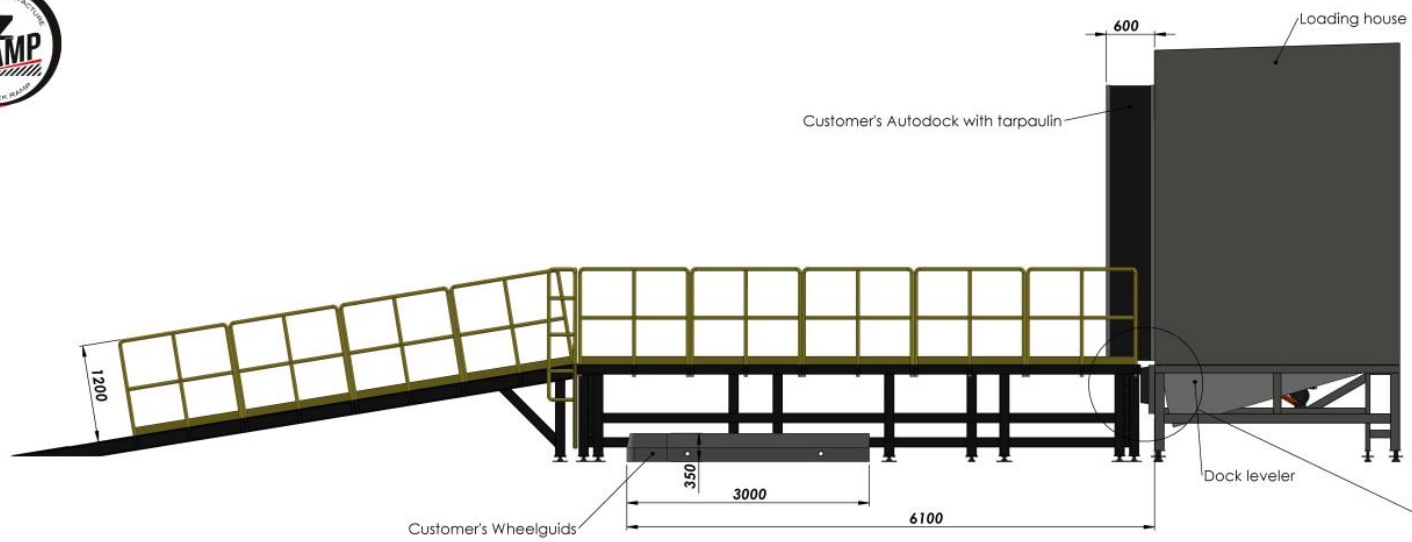

NAME - SURNAME	DATE	SIGN	QUANTITY	MASS (KG)	MATERIAL	PAGE NR
DRAWN BY: H. CANSEVER	25.08.2022		---			1/2
CONTROL: A. HEPBILDI	25.08.2022					
APPROVAL: S. ENTZMANN	25.08.2022					
SCALE: 1:100						
PART/ASSEMBLY NAME			DRAWING DESCRIPTION		DRAWING NO.	
			#(#E2CD		---	



AZ MACHINERY - SLU, Matériels d'Élévation et Maintenance
 13 rue de la machine - 66340 PALAU DE CEDEBACQ - France
 Téléphone : +33 (0) 27 48 500 - contact@az-machinery.com - www.az-machinery.com
 Site : AZ 654 958 666 FR - TVA : FR02 824 654 958 - N° EORI : FR02 824 654 958

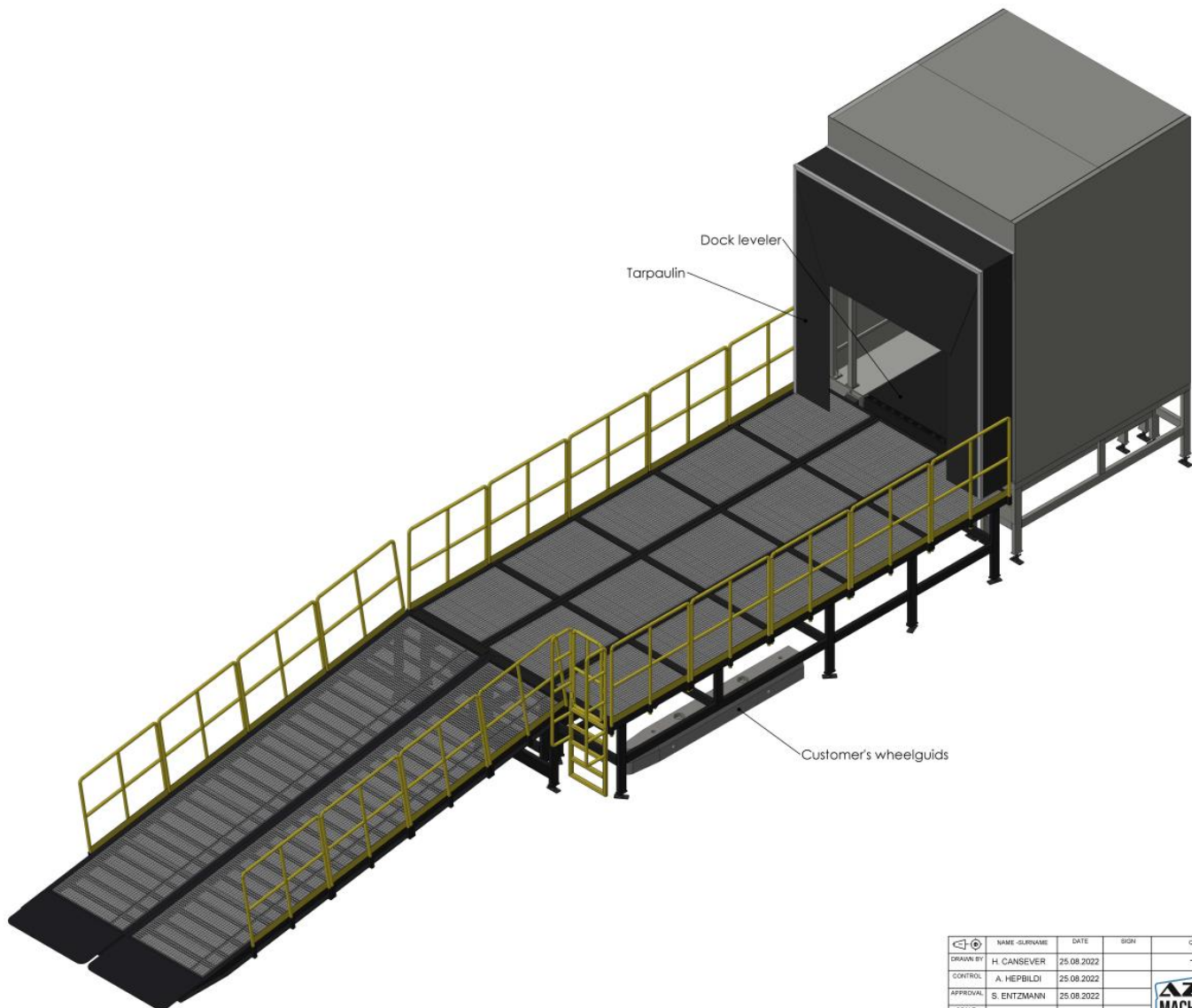

NAME - SURNAME	DATE	SIGN	QUANTITY	MASS (KG)	MATERIAL	PAGE NR
DRAWN BY: H. CANSEVER	25.08.2022		---			2/2
CONTROL: A. HEPBILDI	25.08.2022					
APPROVAL: S. ENTZMANN	25.08.2022					
SCALE: 1:100						
PARTS/ASSEMBLY NAME			DRAWING DESCRIPTION		DRAWING NO.	
			#(#E2CD		---	



AZ MACHINERY - SLU, Matériels d'Élévation et Maintenance
 13 rue de la scierie - 66340 PALLATI DE CERDAGNE - France
 Téléphone : +33 (0) 37 48 500 - contact@az-machinery.com - www.az-machinery.com
 Site : 424 654 958 666 19 - TVA : FR02 824 654 958 - N° EORI : FR02 824 654 958

5
4

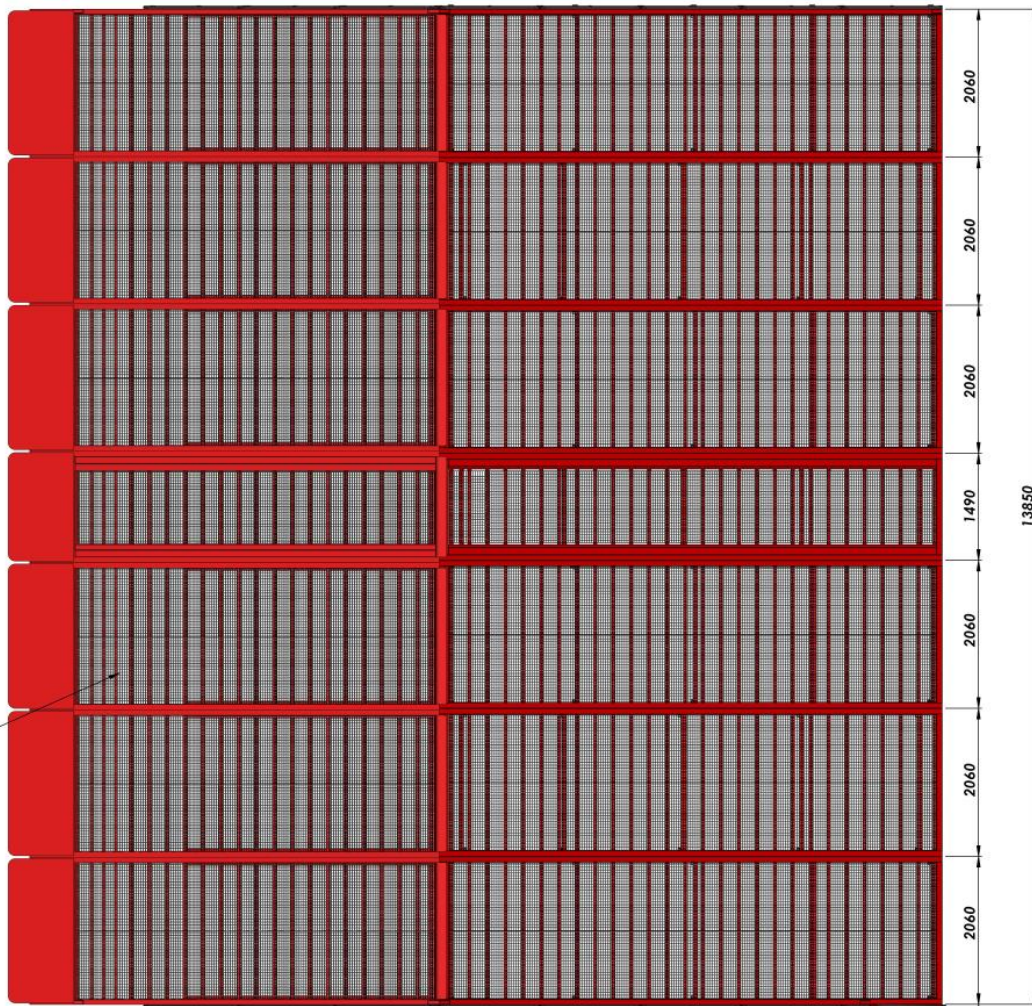

All floor is galvanised grid

All sides have UNP160 wheel guard

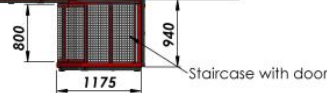
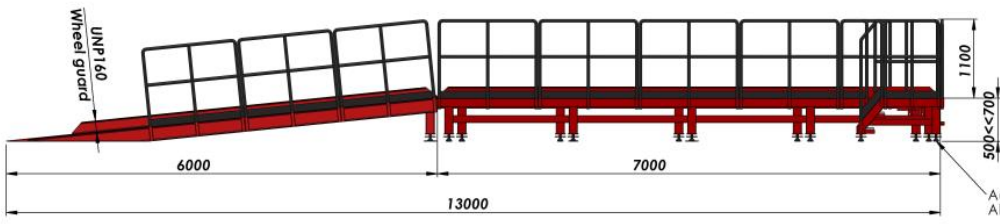

Staircase with door

NAME - SURNAME	DATE	SIGN	QUANTITY	MASS (KG)	MATERIAL	PAGE NR
DRAWN BY: H. CANSEVER	07.01.2023		---			1/2
CONTROL: A. HEPBILDI	07.01.2023					
APPROVAL: S. ENTZMANN	07.01.2023					
SCALE: 1:100						
PART/ASSEMBLY NAME			DRAWING DESCRIPTION		DRAWING NO.	
			#V7TB		---	



AZ MACHINERY - SLU, Matériels d'Élévation et Manutention
 13 rue de la Halle - 46 540 PUYLASSI DE CEEBACHEN - France
 Téléphone : +33 (0) 37 48 500 - contact@az-machinery.com - www.az-machinery.com
 Site : 824 654 958 000 FR - TVA : FR02 824 654 958 - 3° EORL - REAO 824 654 958



DRAWINGS

- Rampes mobiles
- Rampes fixes
- Plateformes logistiques
- Rampes de quai
- Réhausse
- Tables de quai mobiles
- Tables de quai fixes
- Passerelles
- Rampes pour conteneurs
- Niveleurs
- Fournitures de quai

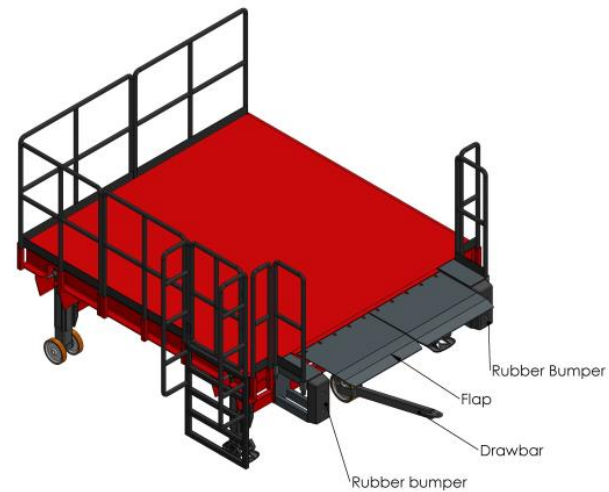
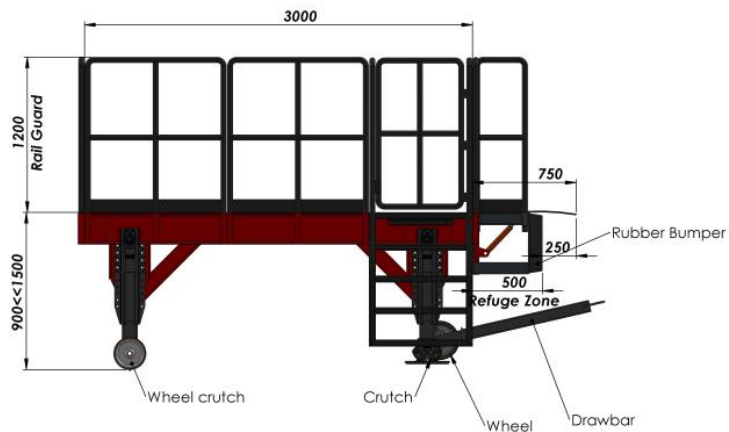
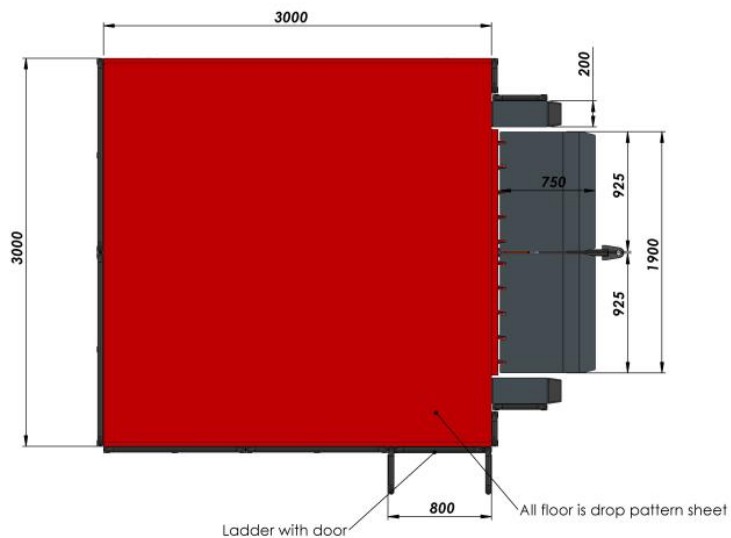

NAME - SURNAME	DATE	SIGN	QUANTITY	MASS (KG)	MATERIAL	PAGE NR
DRAWN BY: H. CANSEVER	26.08.2022		---			1/2
CONTROL: A. HEPBILDI	26.08.2022					
APPROVAL: S. ENTZMANN	26.08.2022					
SCALE: 1:50						
PARTSSEMBLY NAME			DRAWING DESCRIPTION		DRAWING NO.	
			#CK92 3000X3000 PLATFORM		---	



AZ MACHINERY - SLU, Matériels d'Élévation et Maintenance
 13 rue de la scierie - 46 340 PALLAT DE CEEBACHS - France
 Téléphone : +33 (0) 37 45 500 - contact@az-machinery.com - www.az-machinery.com
 Site : 824 654 958 (0011) - TVA : FR02 824 654 958 - 3^e EORL - FRAD 824 654 958

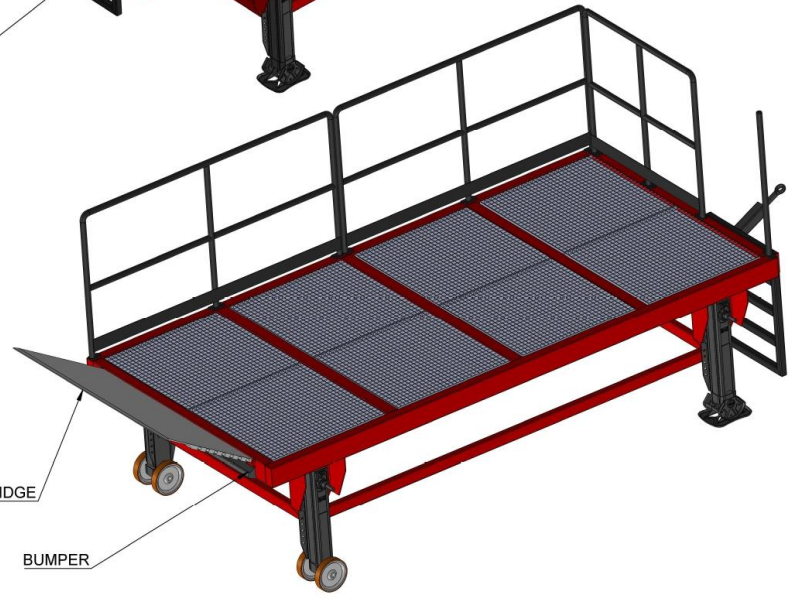
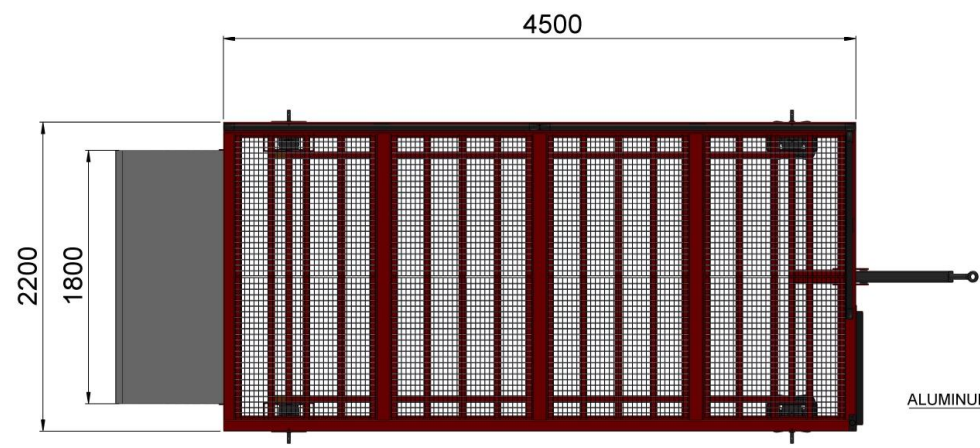
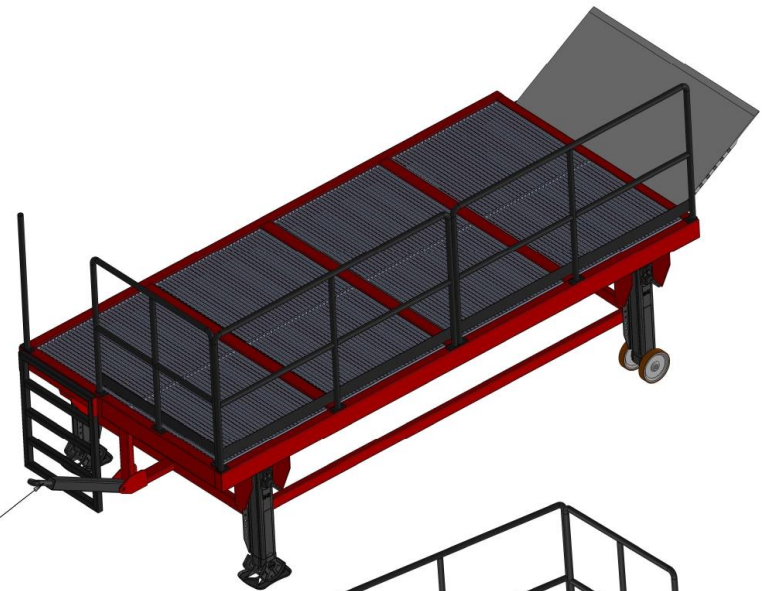
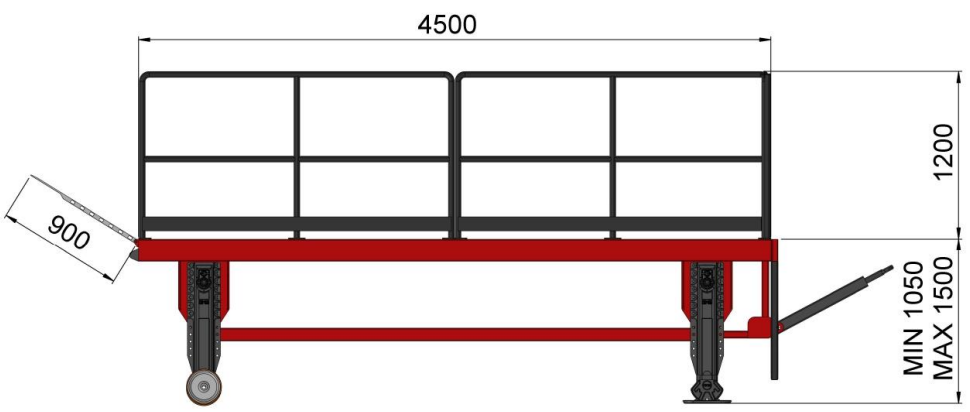

NAME-SURNAME	DATE	SIGN	QUANTITY	MASS (KG)	MATERIAL	PAGE NR
DRAWN BY H. CANSEVER	27.07.2021		---			1/1
CONTROL A. HEPBILDI	27.07.2021					
APPROVAL S. ENTZMANN	27.07.2021					
SCALE 1:50						
PART/ASSEMBLY NAME	DRAWING DESCRIPTION		DRAWING NO			
	FRA-ORD-52		---			

AZ MACHINERY - SLU, Matériels d'Élévation et Manutention
 13 rue de la scierie - 66340 PALAÏ DE CERDANNES - France
 Téléphone : +33 (0) 27 46 505 - Courriel: az@az-machinery.com - www.az-machinery.com
 Site : S24 654 958 000 FR - TVA : FR02 824 654 958 - N° EORI : FR42 824 654 958

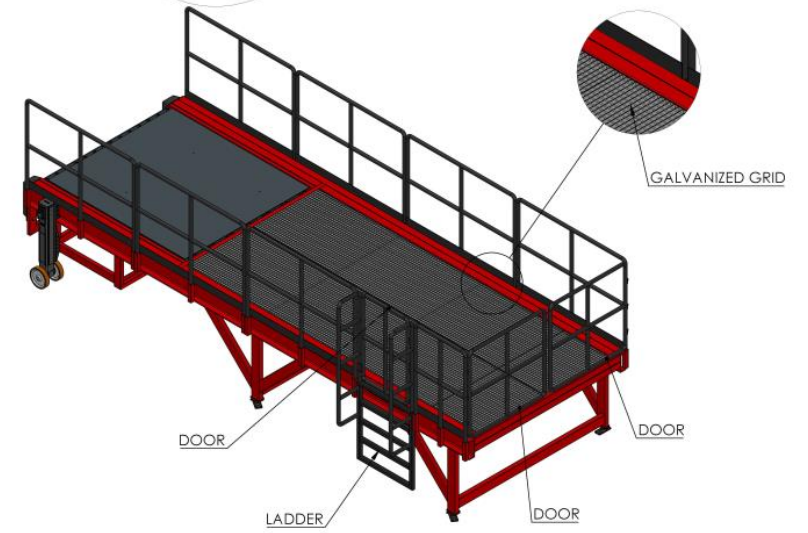
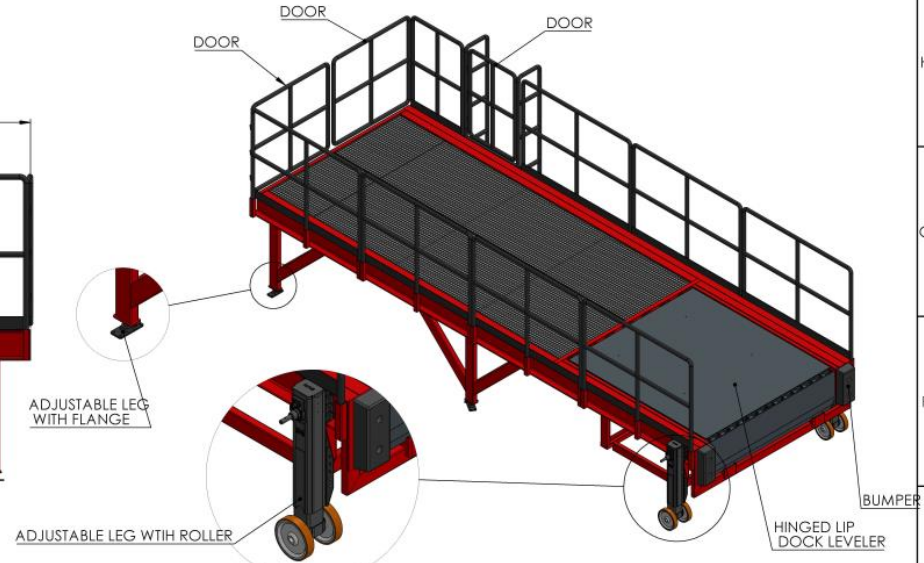
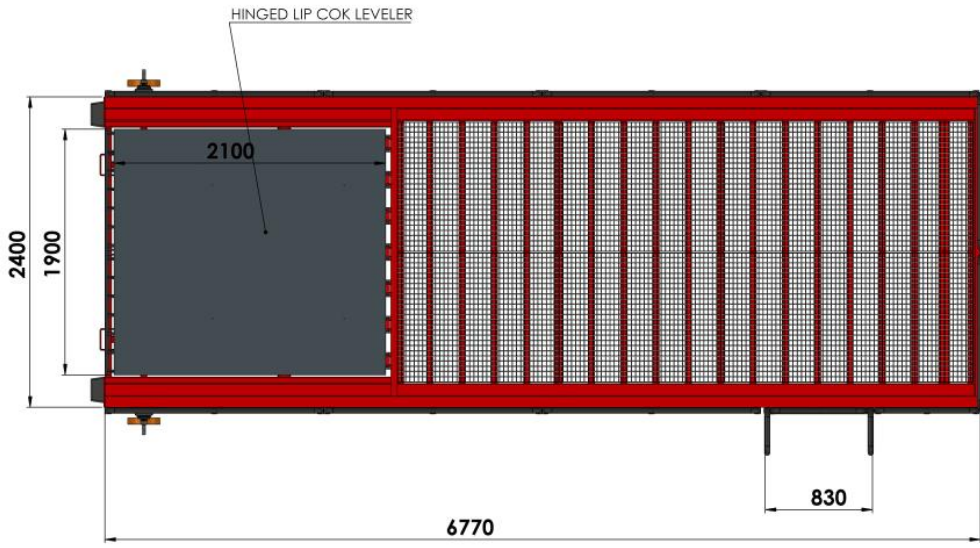
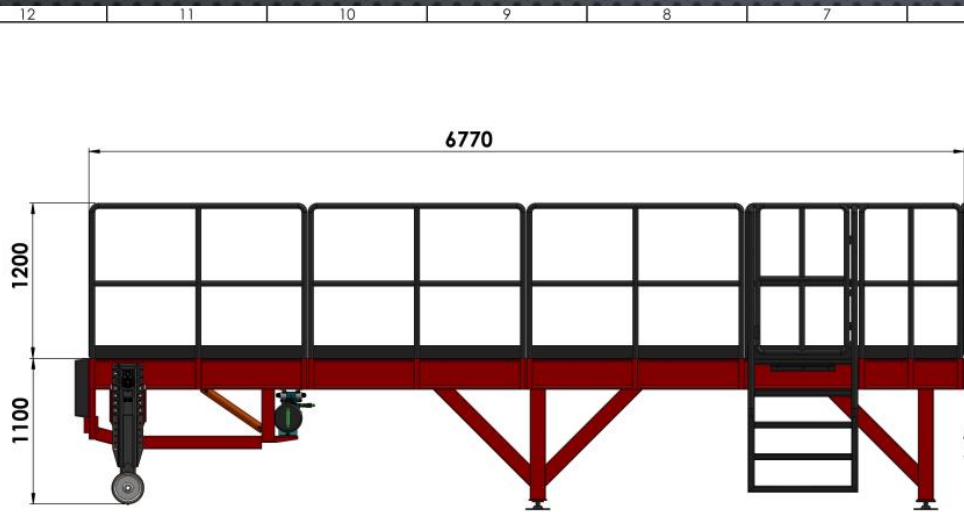

NAME - SURNAME	DATE	SIGN	QUANTITY	MASS (KG)	MATERIAL	PAGE NR
DRAWN BY H. CANSEVER	12.12.2021		---			1/1
CONTROL A. HEPBILDI	12.12.2021					
APPROVAL S. ENTZMANN	12.12.2021					
SCALE 1:50						
PART/ASSEMBLY NAME			DRAWING DESCRIPTION		DRAWING NO.	
			#74K7			

AZ MACHINERY - SLU, Matériels d'Élévation et Maintenance
 13 rue de la source - 46 540 PULVILLIÈRE (CERANVILLE) - France
 Téléphone : +33 (0) 27 45 1501 - contact@az-machinery.com - www.az-machinery.com
 Site : 424 654 958 000 FR - TVA : FR02 824 654 958 - 3^e EORL - FRAD 824 654 958



DRAWINGS

- Rampes mobiles
- Rampes fixes
- Plateformes logistiques
- Rampes de quai
- Réhausse
- Tables de quai mobiles
- Tables de quai fixes
- Passerelles
- Rampes pour conteneurs
- Niveleurs
- Fournitures de quai

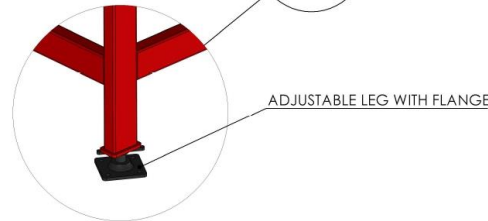
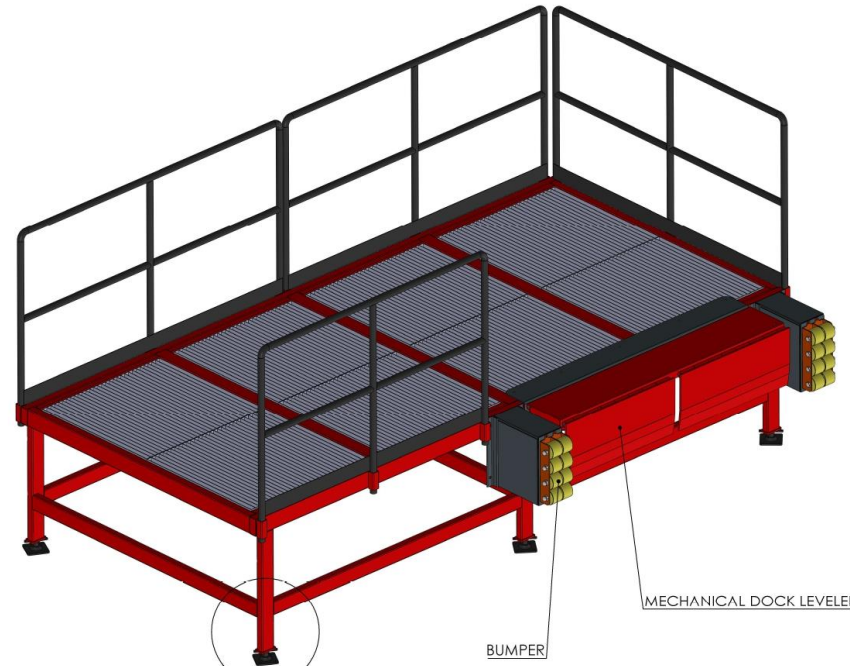
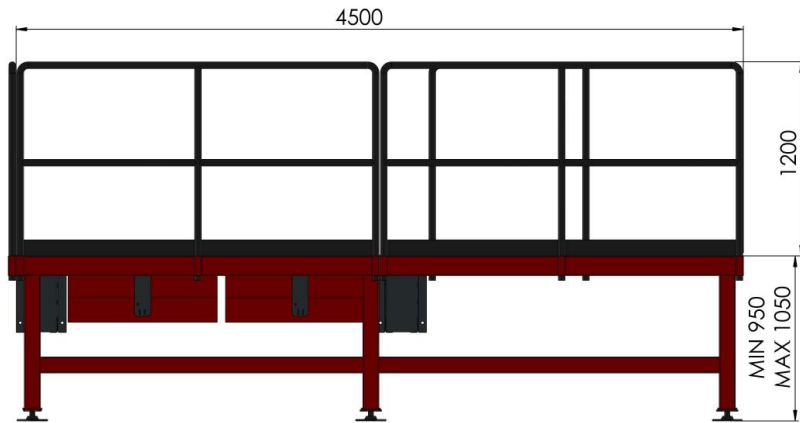
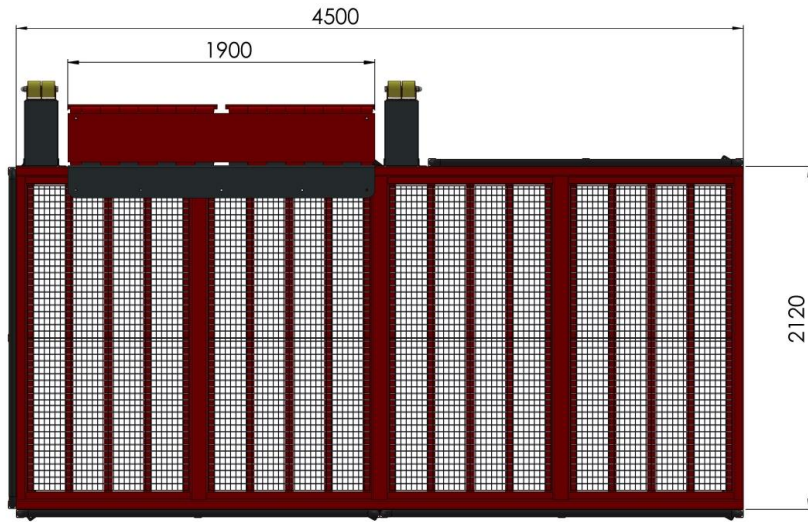

DETAIL A
SCALE 1 : 10

NAME - SURNAME	DATE	SIGN	QUANTITY	MASS (KG)	MATERIAL	PAGE NR
DRAWN BY H. CANSEVER	30.07.2021		---			1/1
CONTROL A. HEPBILDI	30.07.2021					
APPROVAL S. ENTZMANN	30.07.2021					
SCALE 1:50						
PART/ASSEMBLY NAME			DRAWING DESCRIPTION		DRAWING NO	
			FRA-ORD-55		---	



AZ MACHINERY - SLU, Matériels d'Élévation et Manutention
 13 rue de la scierie - 66340 PALAISI DE CERDAGNE - France
 Téléphone : +33 37 37 46 500 - contact@az-machinery.com - www.az-machinery.com
 Site : S24 654 958 000 19 - TVA : FR02 824 654 958 - N° EORI : FRAD 824 654 958

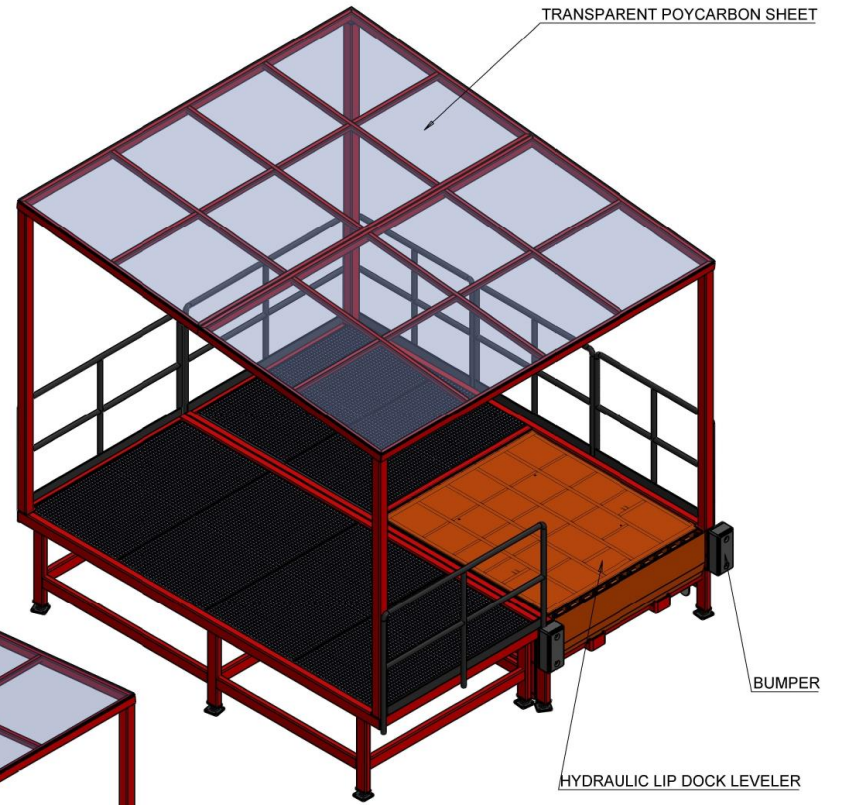
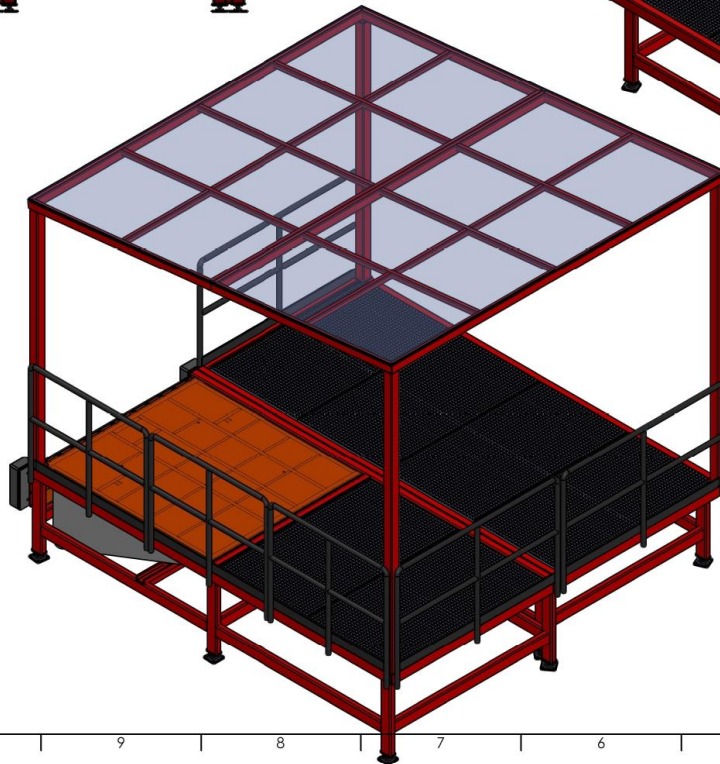
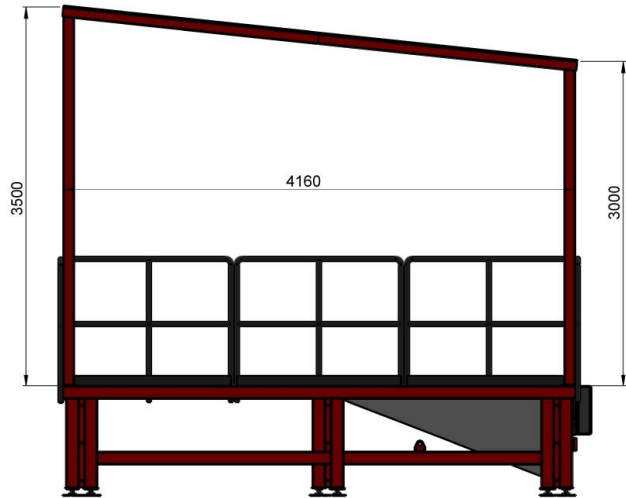

NAME-SURNAME	DATE	SIGN	QUANTITY	MASS (KG)	MATERIAL	PAGE NR
DRAWN BY H. CANSEVER	31.08.2021		---			1/1
CONTROL A. HEPBILDI	31.08.2021					
APPROVAL S. ENTZMANN	31.08.2021					
SCALE 1:50						
PARTASSEMBLY NAME			DRAWING DESCRIPTION			DRAWING NO
			KARL&LEON WITH ROOF			---



AZ MACHINERY - SLU, Matériels d'Élévation et Manutention
13 rue de la scierie - 06340 PALAÏ DE CERDAGNE - France
Téléphone : +33 (0) 37 49 500 - contact@az-machinery.com - www.az-machinery.com
Site : 324 654 958 000 TVA : FR02 824 654 958 - N° EORI : FRAD 824 654 958

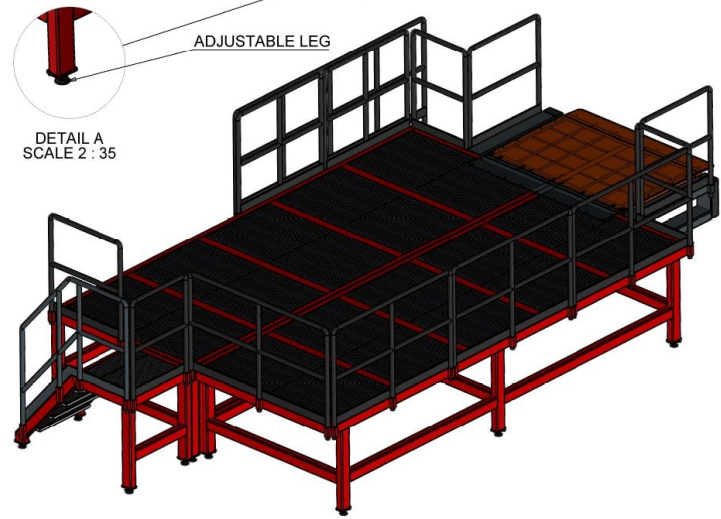
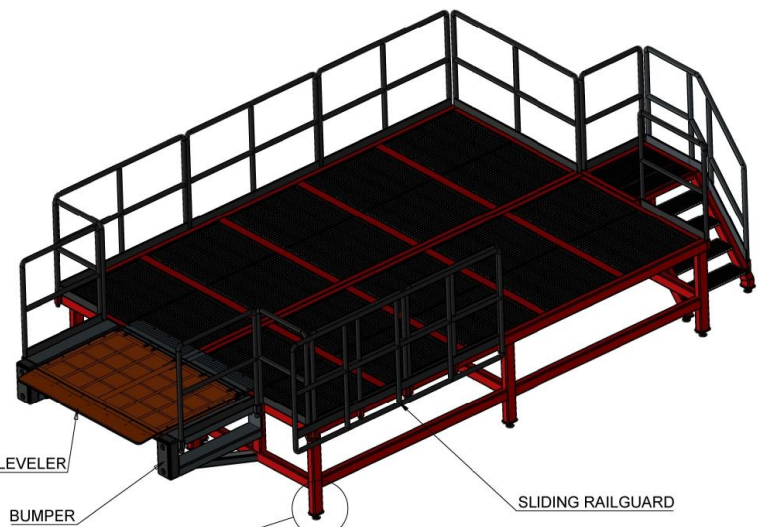
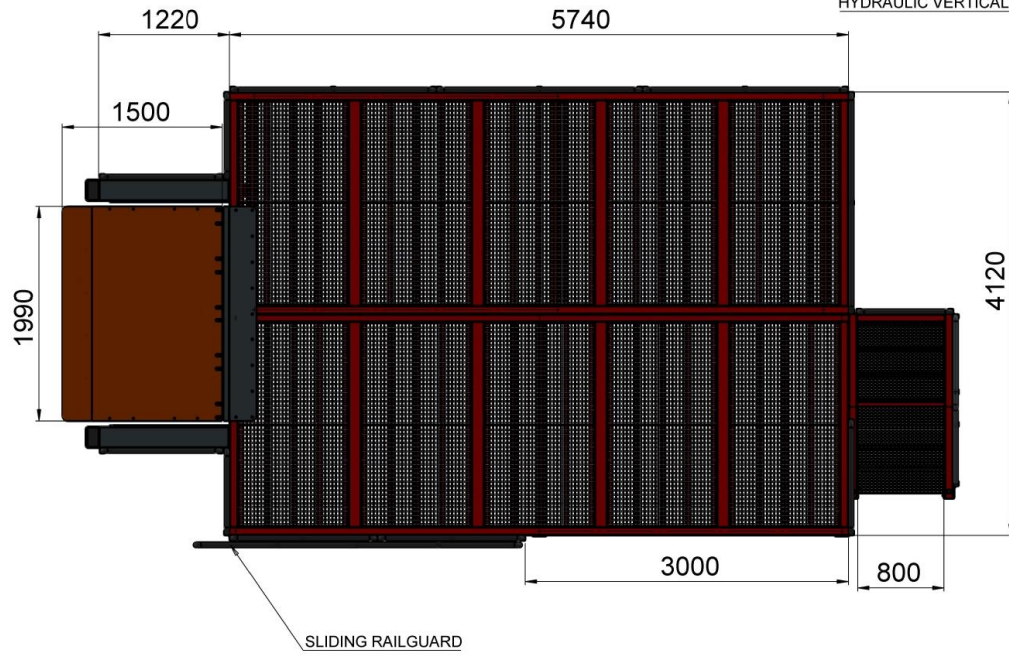
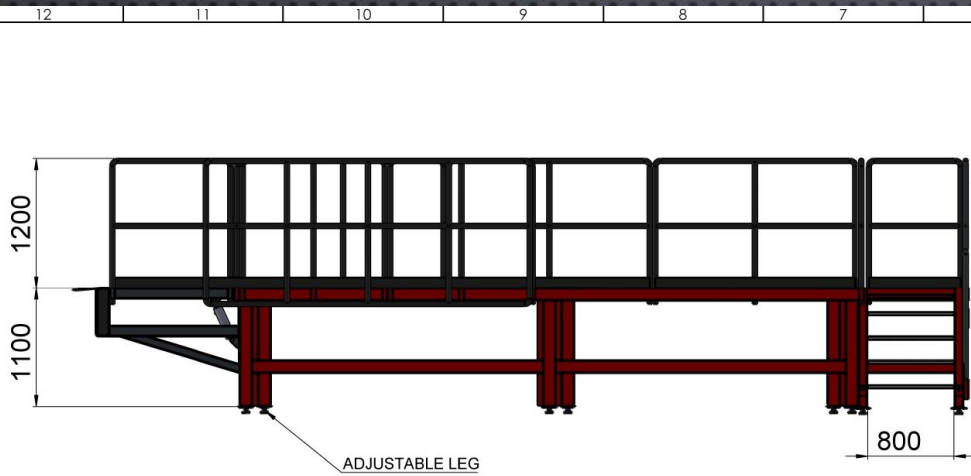

NAME-SURNAME	DATE	SIGN	QUANTITY	MASS (KG)	MATERIAL	PAGE NR
DRAWN BY H. CANSEVER	23.07.2021		---			1/1
CONTROL A. HEPBILDI	23.07.2021					
APPROVAL S. ENTZMANN	23.07.2021					
SCALE 1:50						
PART/ASSEMBLY NAME	DRAWING DESCRIPTION		DRAWING NO.			
	FRA-ORD-50		---			

AZ MACHINERY
AZ MACHINERY - SLU, Matériels d'Élévation et Maintenance
13 rue de la source - 69 340 PALLATI DE CERDAGNE - France
Téléphone : +33 47 27 46 300 - contact@az-machinery.com - www.az-machinery.com
Site : 024 654 958 000 10 - TVA : FR02 824 654 958 - 3^e EGEI - FRA02 824 654 958

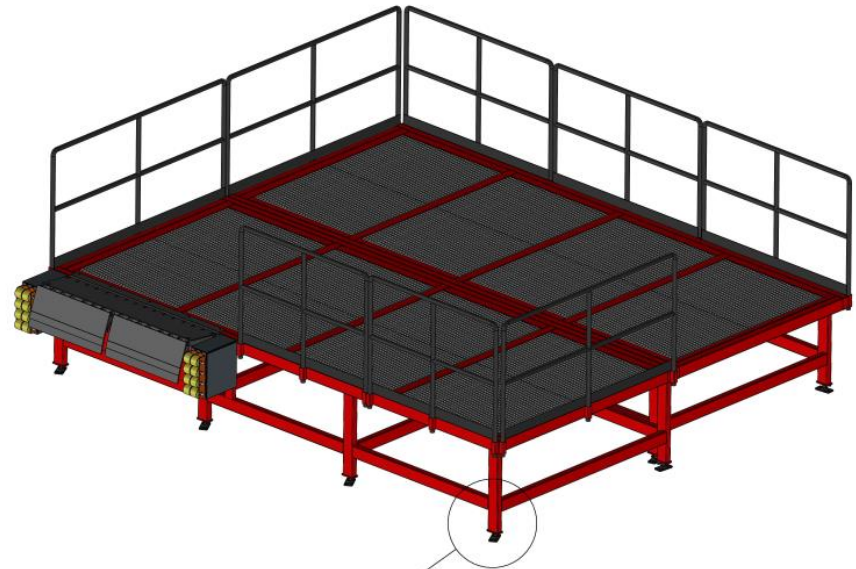
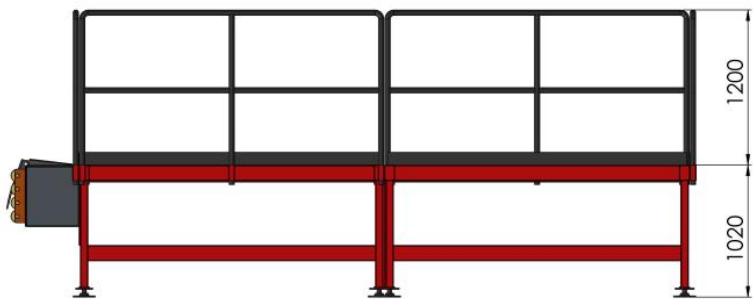
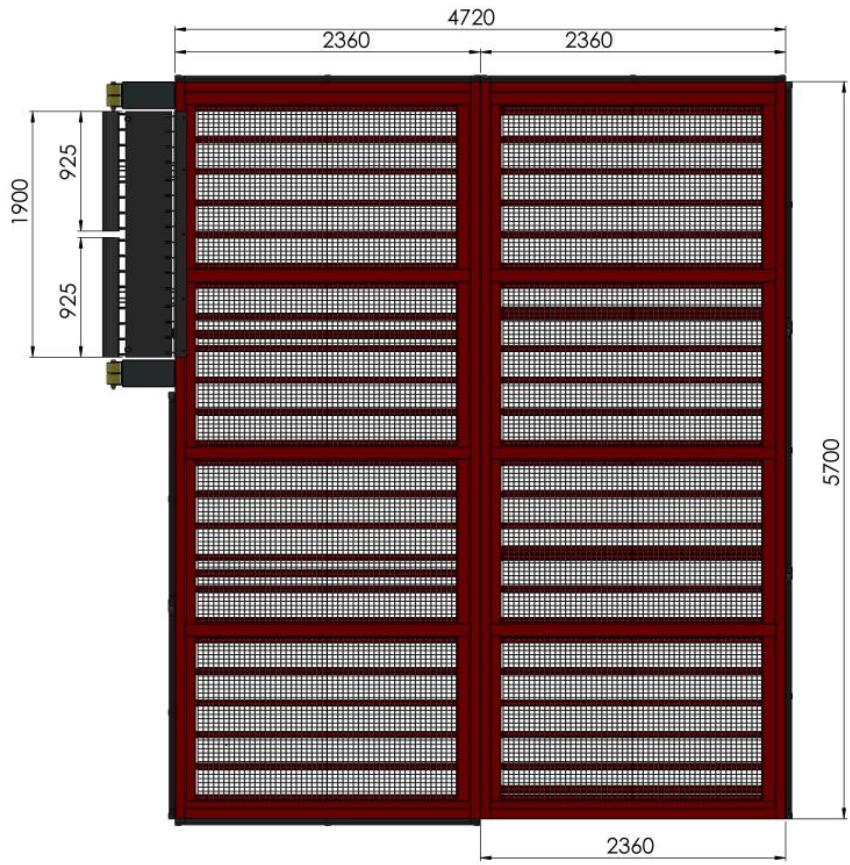

ADJUSTABLE LEG

NAME - SURNAME	DATE	SIGN	QUANTITY	MASS (KG)	MATERIAL	PAGE/SET
DRAWN BY: H. CANSEVER	07.09.2021		---			1/1
CONTROL: A. HEPBILDI	07.09.2021					
APPROVAL: S. ENTZMANN	07.09.2021					
SCALE: 1:50						
PART/ASSEMBLY NAME			DRAWING DESCRIPTION		DRAWING NO.	
			FRA-ORD-61 DOCK TABLE		---	



AZ MACHINERY - SLU, Matériels d'Élévation et Maintenance
 13 rue de la source - 86 340 PALAISEAU DE CERAMIQUE - FRANCE
 Téléphone : +33 (0) 27 48 381 / contact@az-machinery.com / www.az-machinery.com
 Fax : 824 654 958 000 19 - TVA : FR02 824 654 958 - 3^e EGEI - FR03 824 654 958

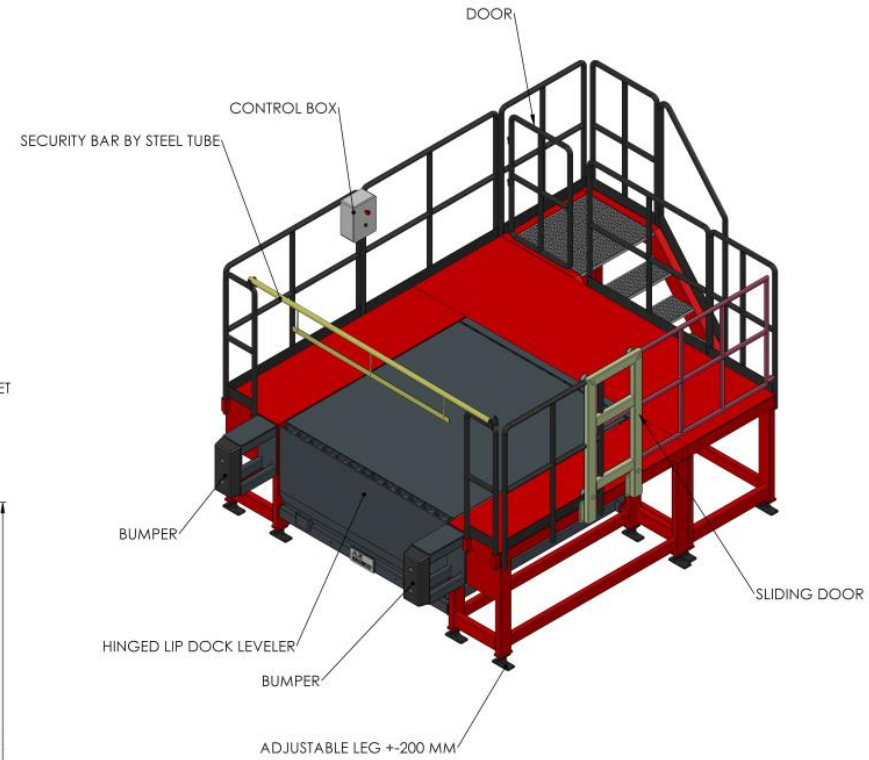
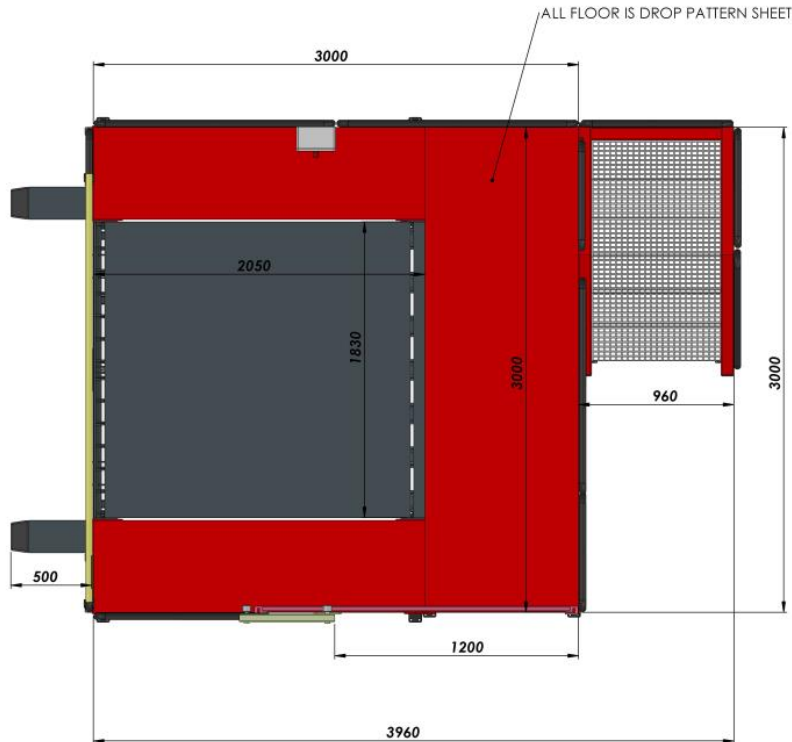
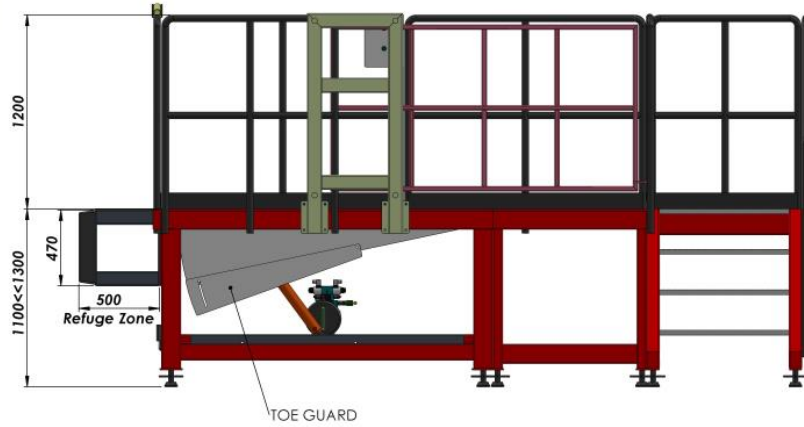

NAME (SURNAME)	DATE	SIGN	QUANTITY	MASS (KG)	MATERIAL	PAGE/18
DRAWN BY: H. CANSEVER	01.09.2022		---			1/2
CONTROL: A. HEPBILDI	01.09.2022					
APPROVAL: S. ENTZMANN	01.09.2022					
SCALE: 1:50						
PART/ASSEMBLY NAME			DRAWING DESCRIPTION		DRAWING NO.	
			#CK92 3000X3000 DISPATCH		---	



AZ MACHINERY - SLU, Matériels d'Élévation et Manutention
 13 rue de la mairie - 86 340 PALAIS DE CÉRÉBIANDRE - FRANCE
 Téléphone : +33 (0) 27 46 361 - contact@az-machinery.com - www.az-machinery.com
 Fax : 824 654 958 (001) - TVA : FR02 824 654 958 - 3^e E08E1 - FR02 824 654 958

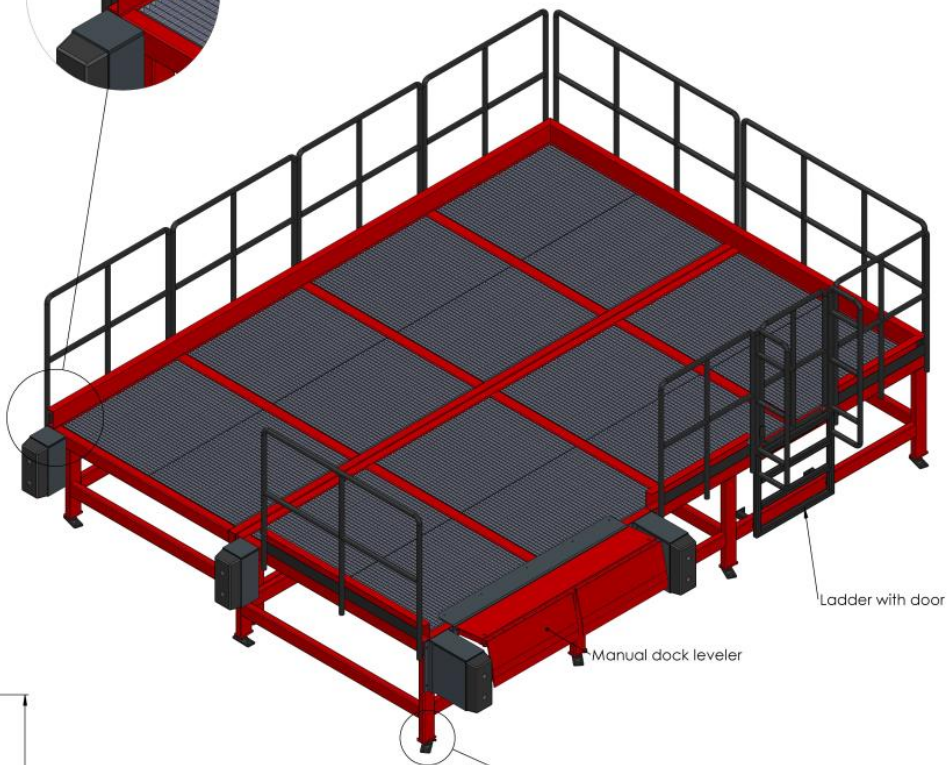
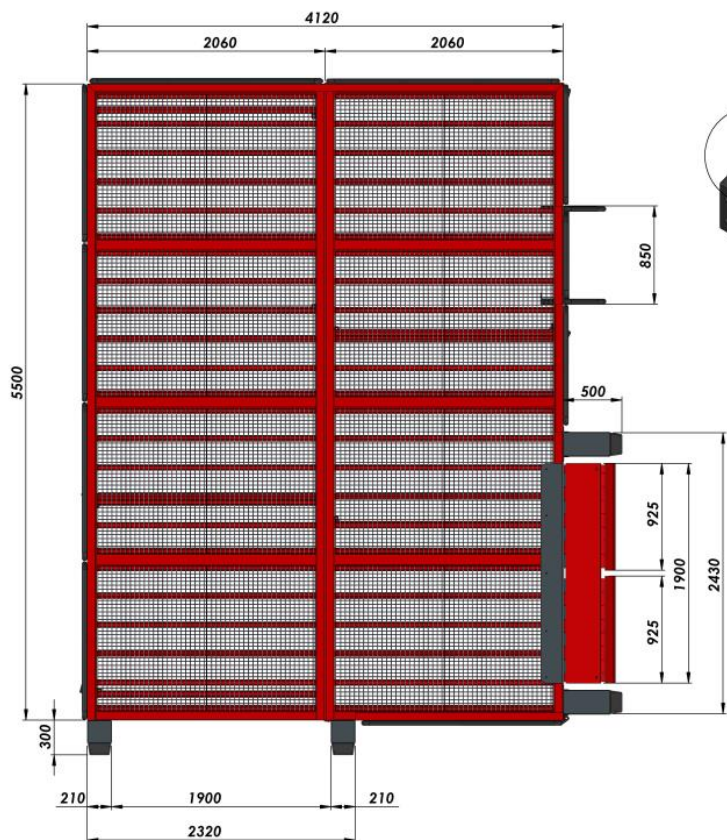
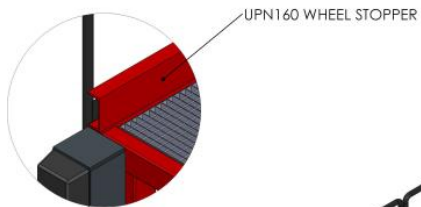
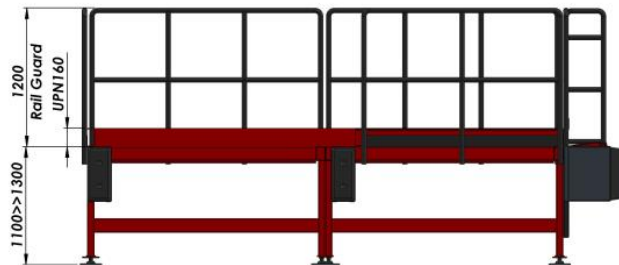

NAME - SURNAME	DATE	SIGN	QUANTITY	MASS (KG)	MATERIAL	PAGE/NT
DRAWN BY: H. CANSEVER	01.08.2022		---			1/2
CONTROL: A. HEPBILDI	01.08.2022					
APPROVAL: S. ENTZMANN	01.08.2022					
SCALE: 1:50						
PARTASSEMBLY NAME	DRAWING DESCRIPTION:		DRAWING NO.			
	#22TT		---			



AZ MACHINERY - SLU, Matériels d'Élévation et Manutention
13 rue de la source - 46 340 PALAISEAU (FRANCE)
Téléphone : +33 (0) 27 48 500 - contact@az-machinery.com - www.az-machinery.com
Site : 424 654 958 666 FR - TVA : FR02 424 654 958 - N° EORI : FR02 424 654 958

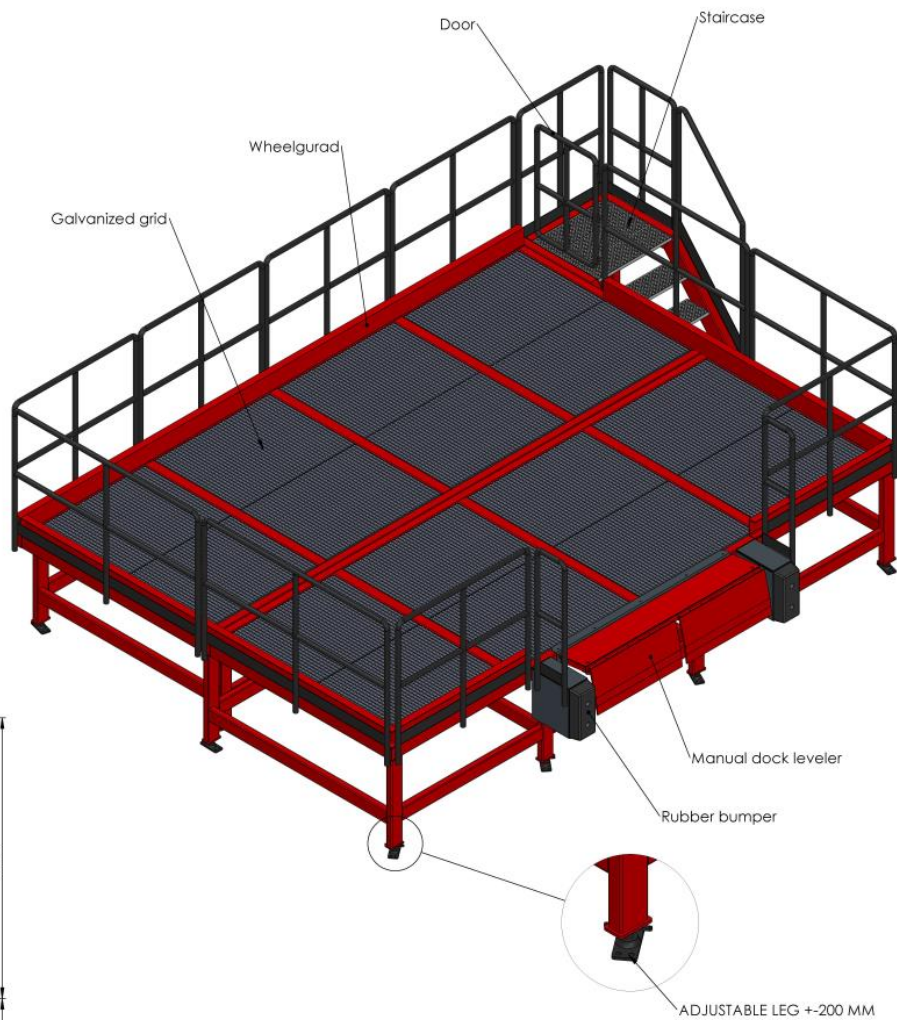
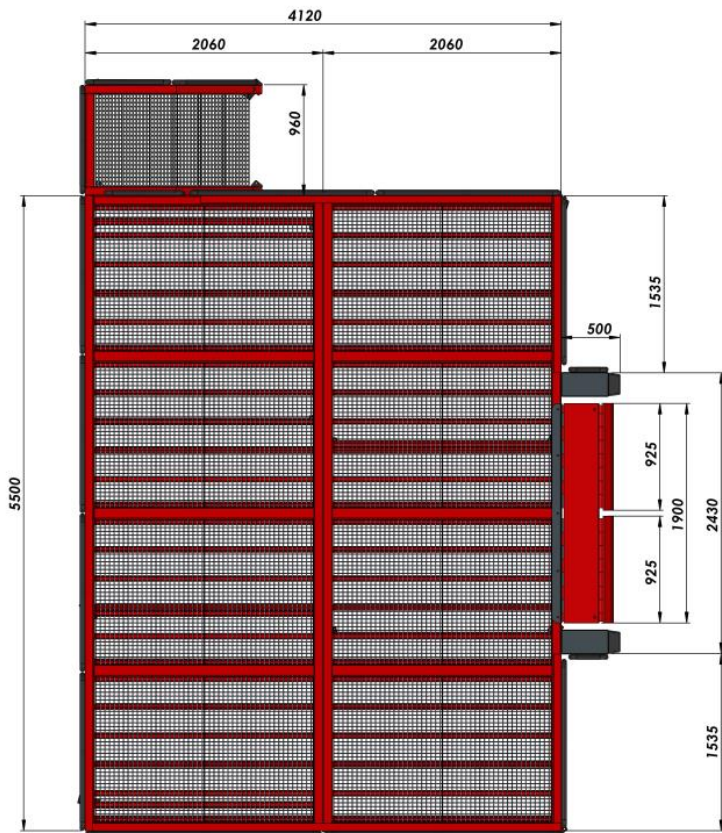
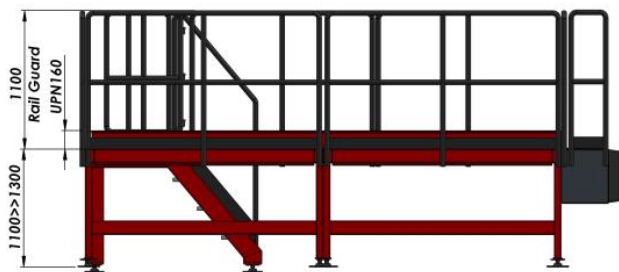

NAME - SURNAME	DATE	SIGN	QUANTITY	MASS (KG)	MATERIAL	PAGE/NT
DRAWN BY: H. CANSEVER	24.10.2022		---			1/2
CONTROL: A. HEPBILDI	24.10.2022					
APPROVAL: S. ENTZMANN	24.10.2022					
SCALE: 1:50						
PART/ASSEMBLY NAME	DRAWING DESCRIPTION:		DRAWING NO.			
	#E46D		---			



AZ MACHINERY - SLU, Matériels d'Élévation et Manutention
 13 rue de la mairie - 86 340 PALAIS DE CÉRÉBIANDRE - FRANCE
 Téléphone : +33 (0) 27 48 381 / contact@az-machinery.com / www.az-machinery.com
 Fax : 824 654 958 000 19 - TVA : FR02 824 654 958 - 3^e EURE / FR02 824 654 958

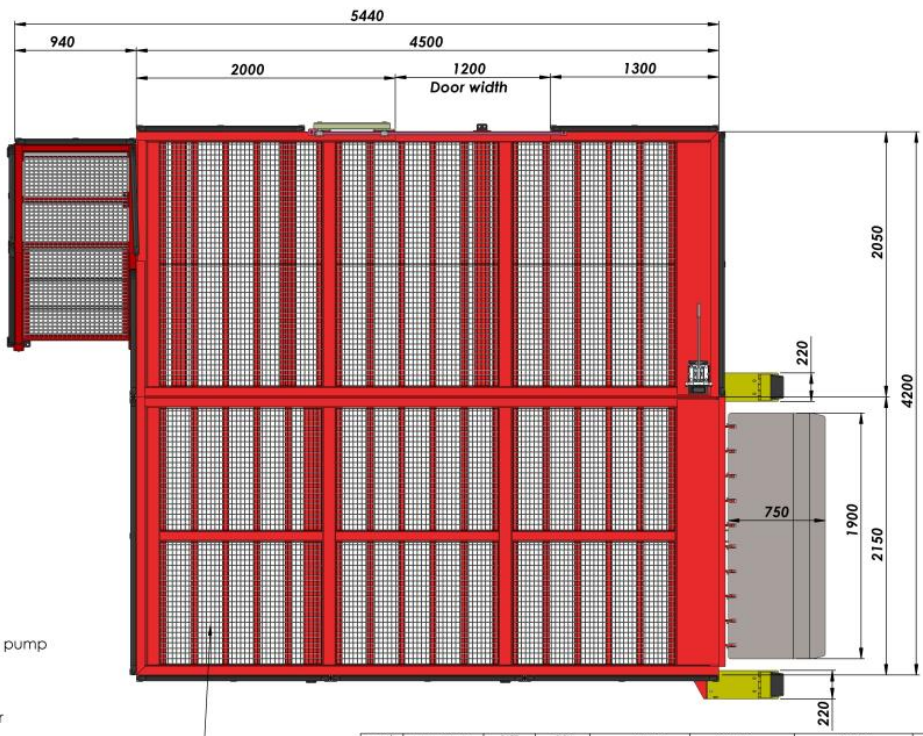
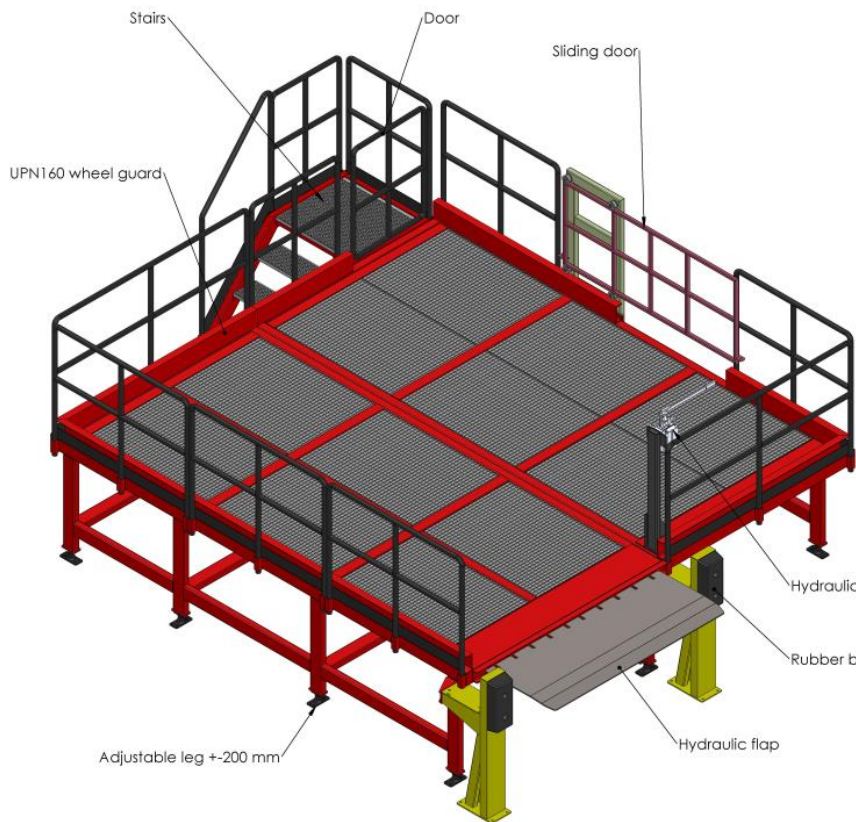
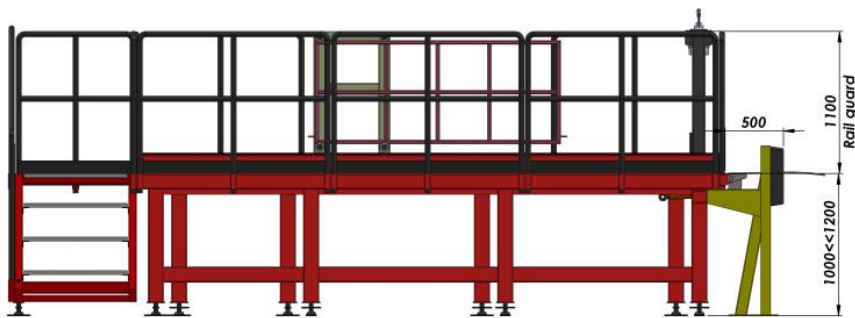
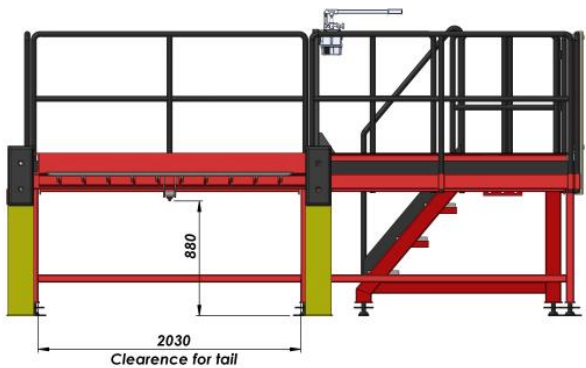

All floor is galvanised grid

NAME - SURNAME	DATE	SIGN	QUANTITY	MASS (KG)	MATERIAL	PAGE/18
H. CANSEVER	19.12.2022		---			1/2
A. HEPBILDI	19.12.2022					
S. ENTZMANN	19.12.2022					
SCALE	1:50					
PART/ASSEMBLY NAME	DRAWING DESCRIPTION		DRAWING NO.			
	#5395		---			



AZ MACHINERY - SLU, Matériels d'Élévation et Maintenance
 13 rue de la machine - 66 340 PALAU DE CERDANNE - France
 Téléphone : +33 (0) 27 40 30 00 - contact@az-machinery.com - www.az-machinery.com
 Fax : +33 (0) 27 40 30 01 - TVA : FR02 824 654 958 - 3^e EGEI - FRAD 824 654 958

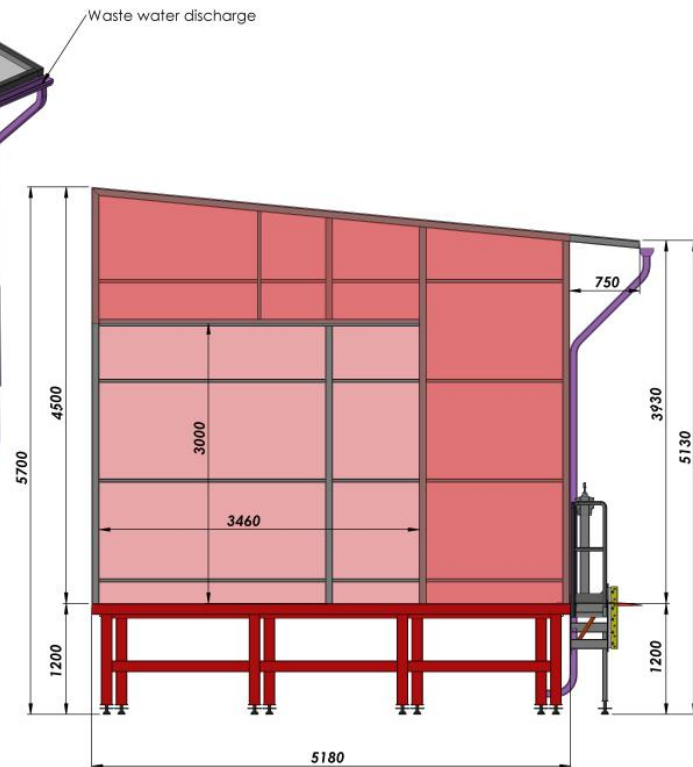
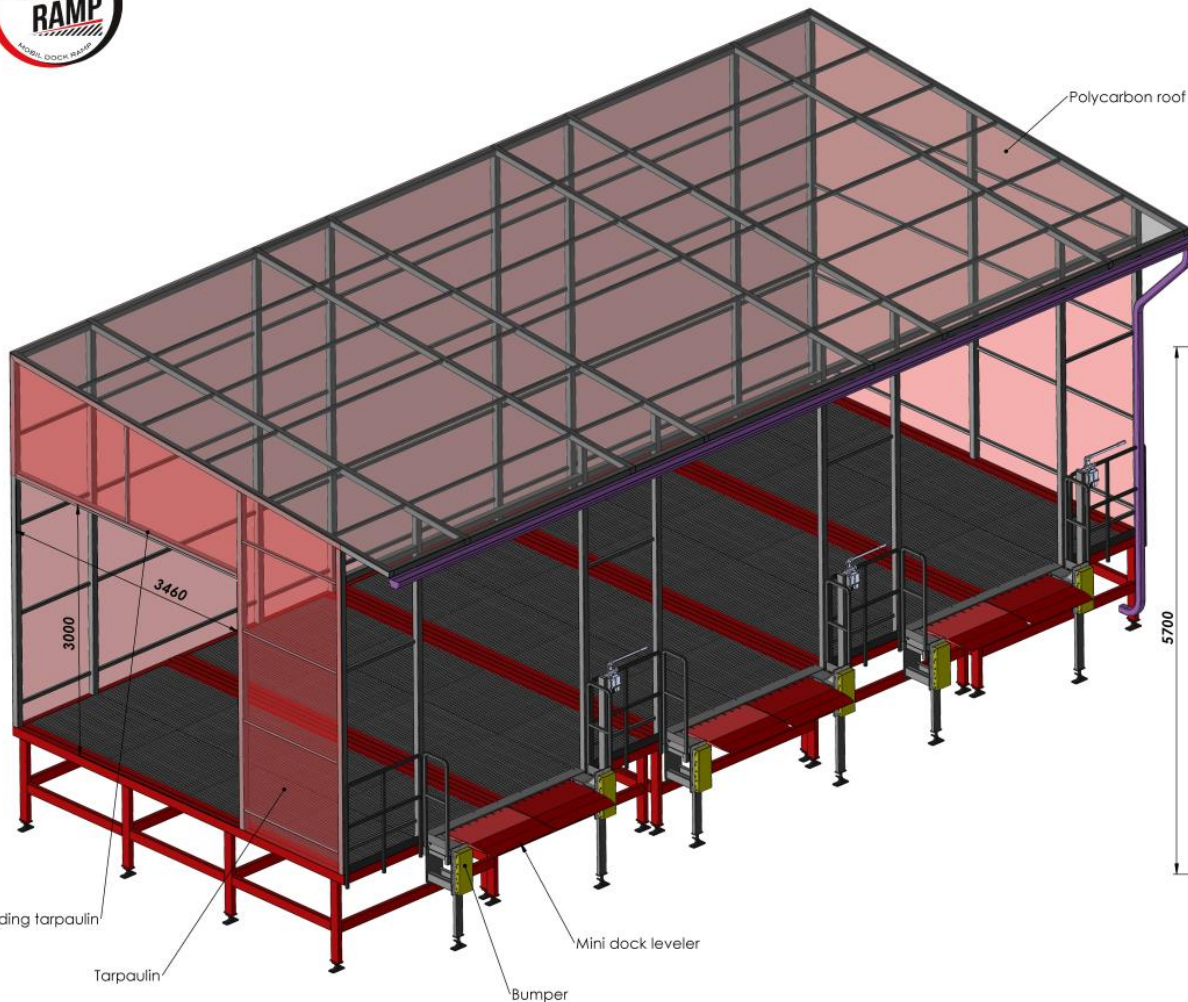

Sliding tarpaulin
Tarpaulin
Mini dock leveler
Bumper

NAME	GLRNAME	DATE	SIGN	QUANTITY	MASS (KG)	MATERIAL	PAGE/NT
DRAWN BY	H. CANSEVER	20.01.2023		---			3/4
CONTROL	A. HEPBILDI	20.01.2023					
APPROVAL	S. ENTZMANN	20.01.2023					
SCALE	1:50						
PART/ASSEMBLY NAME				DRAWING DESCRIPTION		DRAWING NO.	
				#57V4		---	



AZ MACHINERY - SLU, Matériels d'Élévation et Maintenance
13 rue de la source - 66 340 PULATY DE CERBANDRE - France
Téléphone : +33 (0) 37 49 301 - contact@az-machinery.com - www.az-machinery.com
Siret : 824 654 958 000 19 - TVA : FR02 824 654 958 - 3^e EORI : FR02 824 654 958

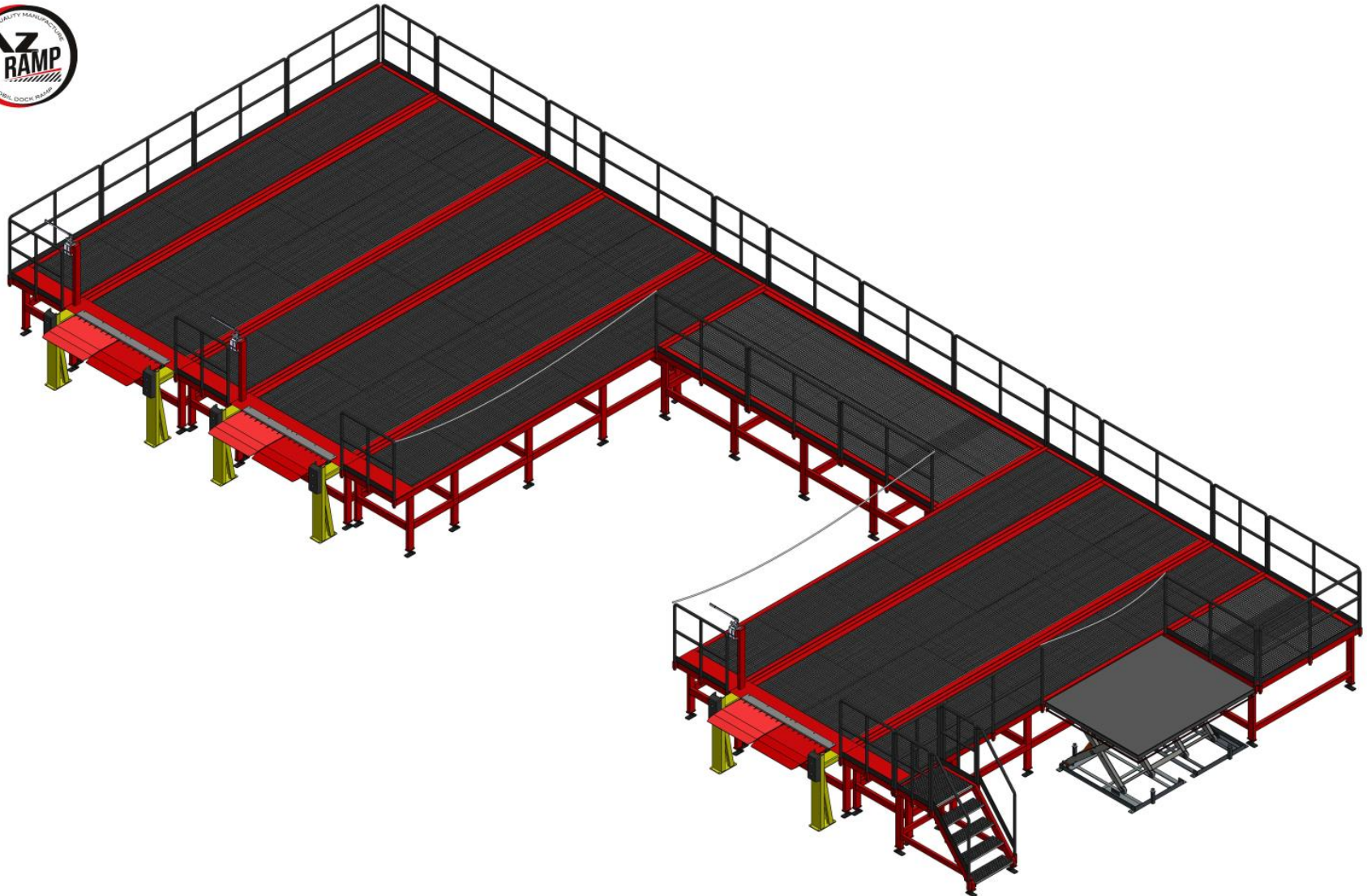

NAME (SURNAME)	DATE	SIGN	QUANTITY	MASS (KG)	MATERIAL	PAGE/MT
DRAWN BY: H. CANSEVER	10.03.2023		---			2/2
CONTROL: A. HEPBILDI	10.03.2023					
APPROVAL: S. ENTZMANN	10.03.2023					
SCALE: 1:100						
PART/ASSEMBLY NAME			DRAWING DESCRIPTION		DRAWING NO.	
			#B539		---	



AZ MACHINERY - SLU, Matériels d'Élévation et Maintenance
 13 rue de la machine - 68 340 PALATI DE CERBANDRE - France
 Téléphone : +33 (0) 37 49 301 - contact@az-machinery.com - www.az-machinery.com
 Fax : 824 654 958 000 19 - TVA : FR02 824 654 958 - 3^e E0081 - FR03 824 654 958

7
0



DRAWINGS

- Rampes mobiles
- Rampes fixes
- Plateformes logistiques
- Rampes de quai
- Réhausse
- Tables de quai mobiles
- Tables de quai fixes
- Passerelles
- Rampes pour conteneurs
- Niveleurs
- Fournitures de quai

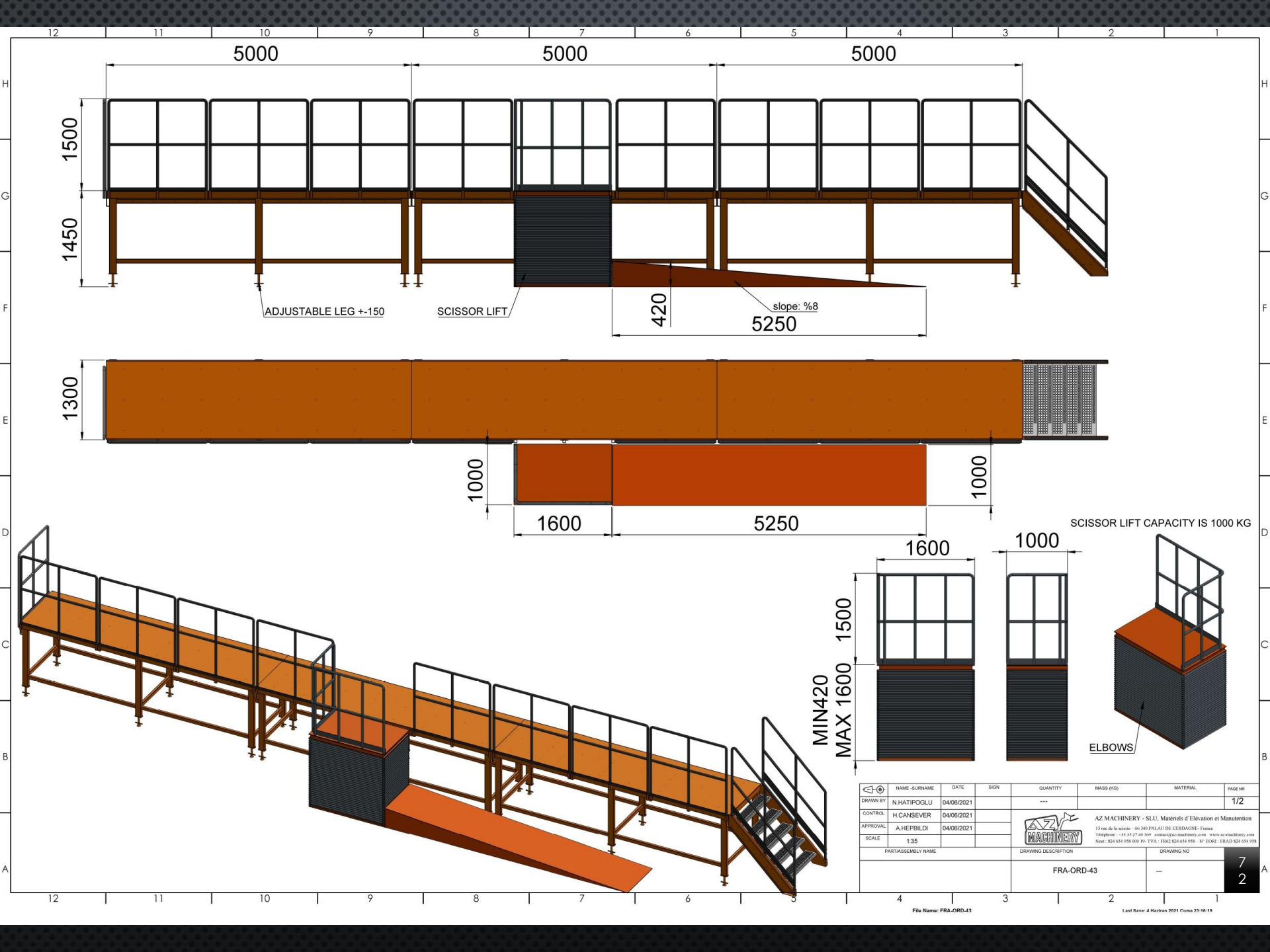

5000

5000

5000

1500

1450

ADJUSTABLE LEG +150

SCISSOR LIFT

420

slope: %8
5250

1300

1000

1600

5250

1000

SCISSOR LIFT CAPACITY IS 1000 KG

1600

1000

MIN 420
MAX 1600

1500

ELBOWS

NAME-SURNAME	DATE	SIGN	QUANTITY	MASS (KG)	MATERIAL	PAGE NR
DRAWN BY N.HATIPOGLU	04/06/2021		---			1/2
CONTROL H.CANSEVER	04/06/2021					
APPROVAL A.HEPBILDI	04/06/2021					
SCALE 1:35						
PART/ASSEMBLY NAME	DRAWING DESCRIPTION		DRAWING NO			
	FRA-ORD-43		---			

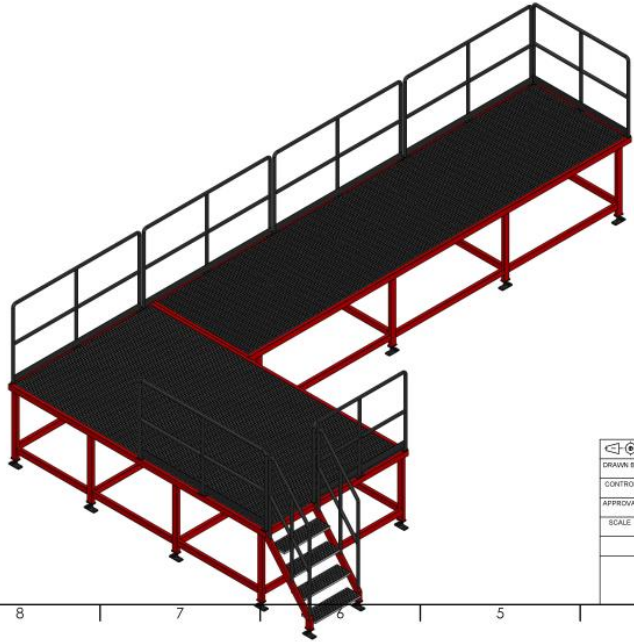
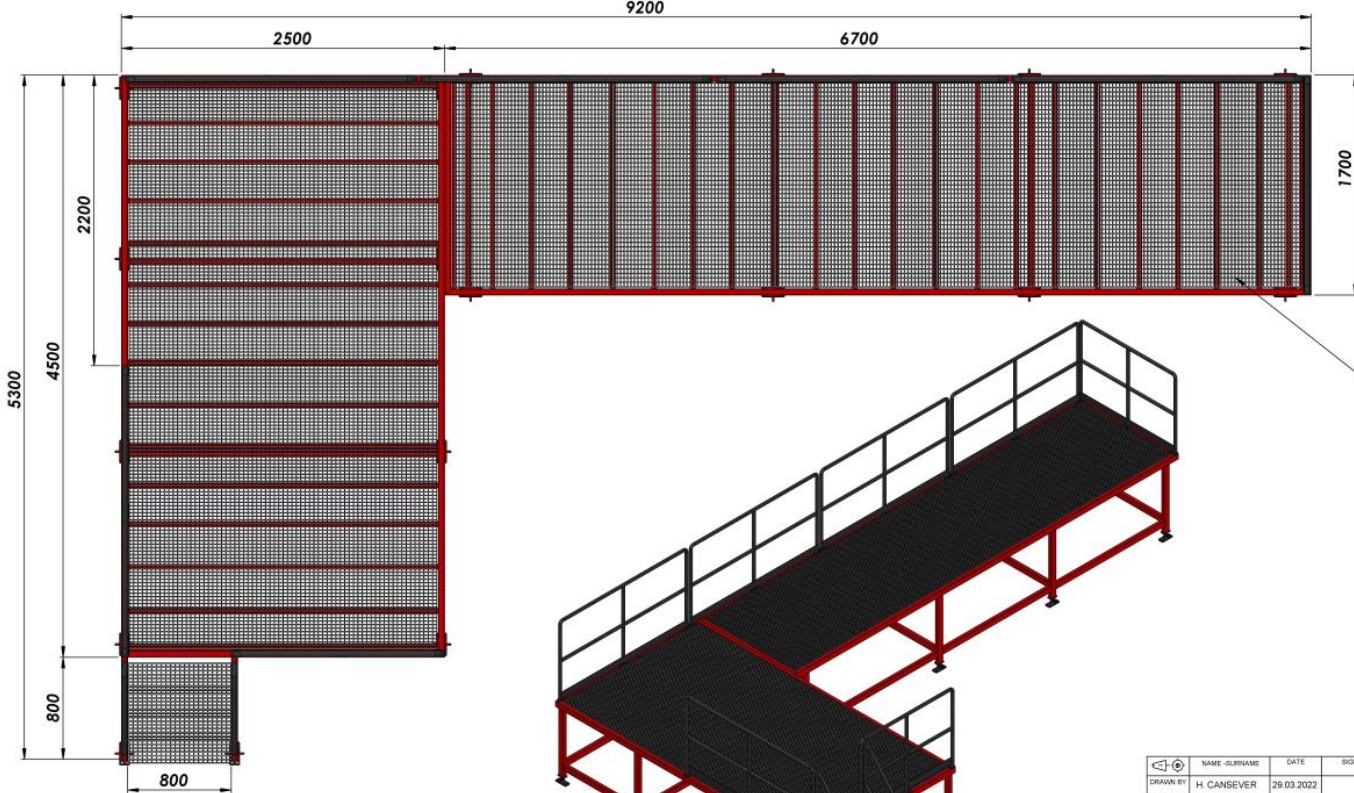
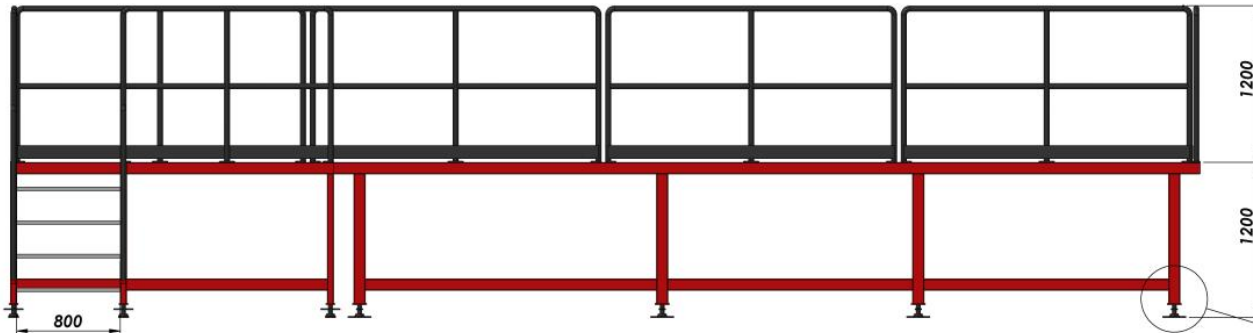

CAPACITY: 500 KG

NAME - SURNAME	DATE	SIGN	QUANTITY	MASS (KG)	MATERIAL	PAGE/SET
DRAWN BY: H. CANSEVER	29.03.2022		---			1/1
CONTROL: A. HEPBILDI	29.03.2022					
APPROVAL: S. ENTZMANN	28.03.2022					
SCALE: 1:100						
PART/ASSEMBLY NAME	DRAWING DESCRIPTION		DRAWING NO.			
#9TDC	CUSTOMIZED PLATFORM WITH STAIR		---			



AZ MACHINERY - SLU, Matériels d'Élévation et Maintenance
 13 rue de la scierie - 340 PALLAS DE CERDANNE - France
 Téléphone : +33 03 27 48 500 contact@az-machinery.com www.az-machinery.com
 Fax : +33 03 27 48 500



DRAWINGS

Rampes mobiles

Rampes fixes

Plateformes logistiques

Rampes de quai

Réhausse

Tables de quai mobiles

Tables de quai fixes

Passerelles

Rampes pour conteneurs

Niveleurs

Fournitures de quai

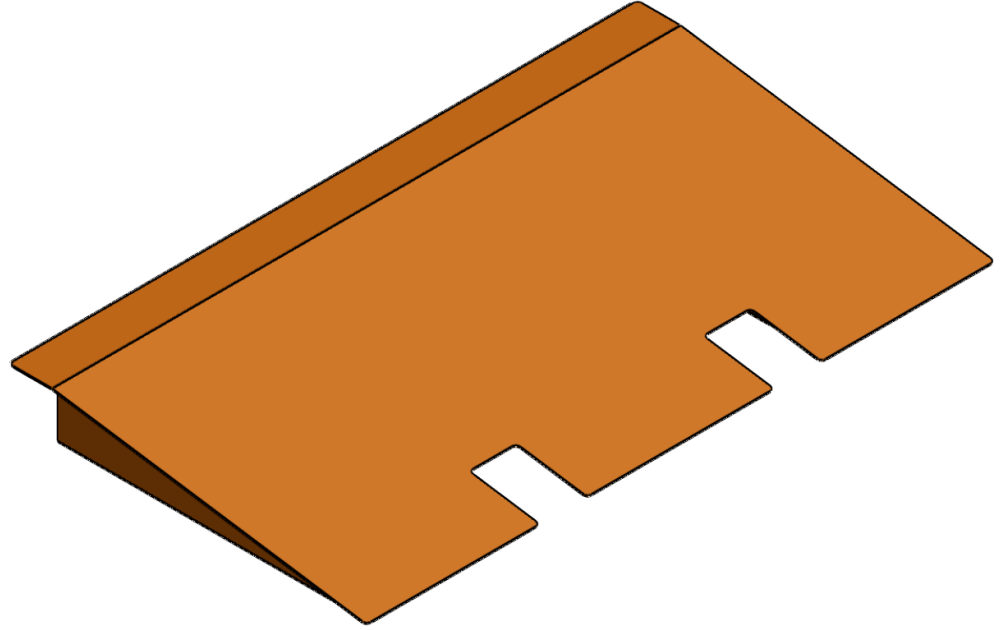
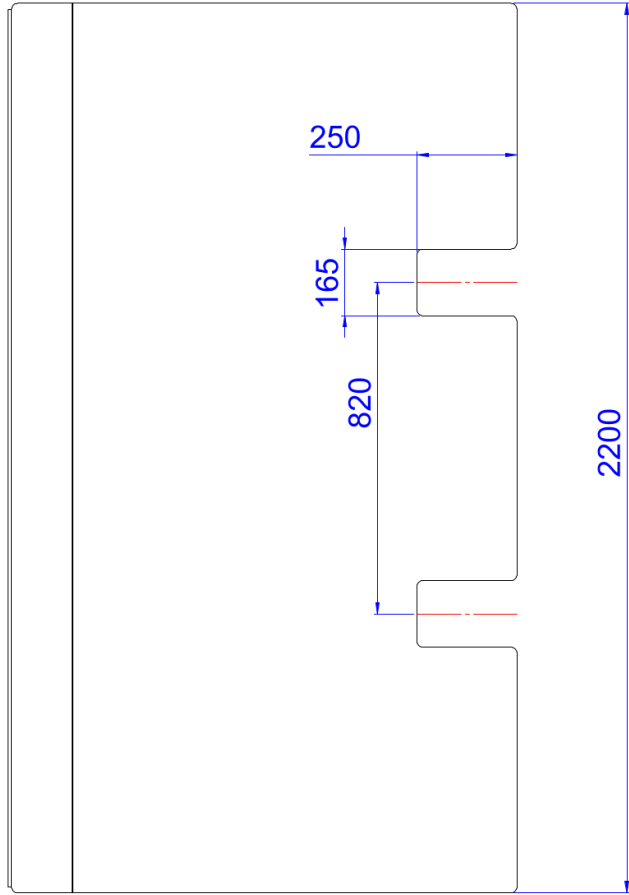
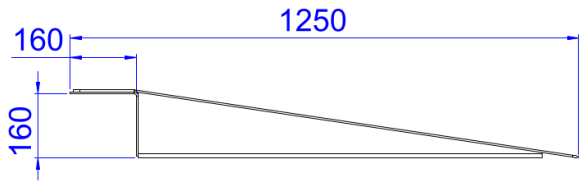

ADI - SOYADI NAME - SURNAME	TARİH DATE	İMZA SIGN	MİKTAR QUANTITY	AĞIRLIK (KG) MASS (KG)	MALZEME MATERIAL	SAYFA NO PAGE NO
N.HATİPOĞLU	25/08/2021		---	200		1/1
KONTROL CONTROL	H.CANSEVER	25/08/2021				
ONAY APPROVAL	A.HEPBİLDİ	25/08/2021				
ÖLÇEK SCALE	1:8					
PARÇA/MONTAJ ADI PART/ASSEMBLY NAME			TEKNİK RESİM AÇIKLAMASI DRAWING DESCRIPTION			RESİM NO DRAWING NO
			CLR-2212			---



AZ MACHINERY - SLU, Matériels d'Élévation et Manutention
13 rue de la vicairie - 06340 PÉRALAS DE CÉREACADE - France
Téléphone : +33 (0) 47 46 100 - contact@az-machinery.com - www.az-machinery.com
Site : S24 654 958 000 10 - TVA : FR02 824 654 958 - N° EORI : FRAD 824 654 958

7
5

Dikkat 1- Resim üzerinden ölçü aleti ile ölçü almayın. 2- Formu veya ölçüsü değişen resimleri teknik büroya bildirin. 3- Resim üzerinde kontrol edenden başkası değişiklik yapamaz.

Dosya adı: CLR-2212

SON KAYIT TARİHİ: 25 Haziran 2021 Cuma 23:51:12

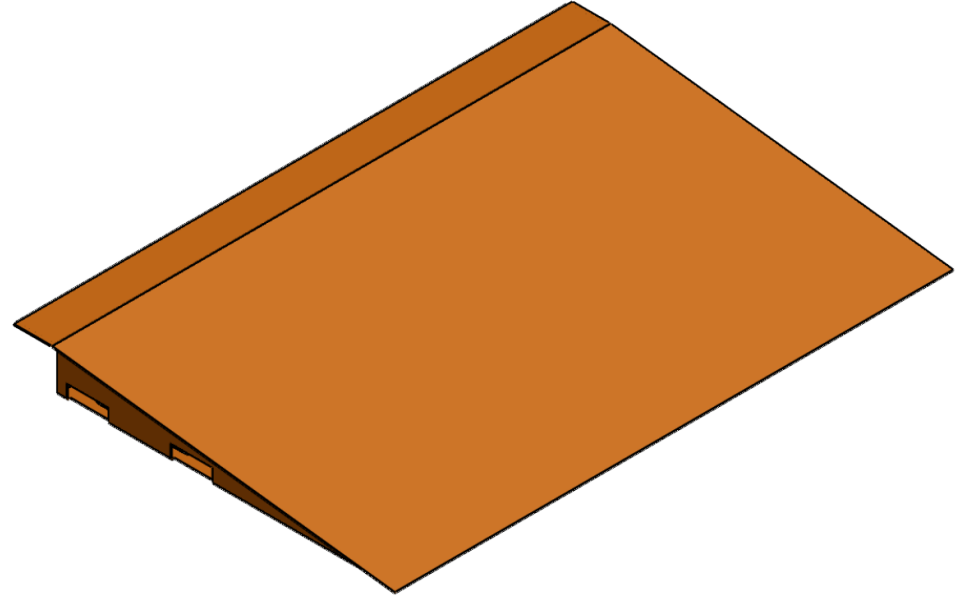
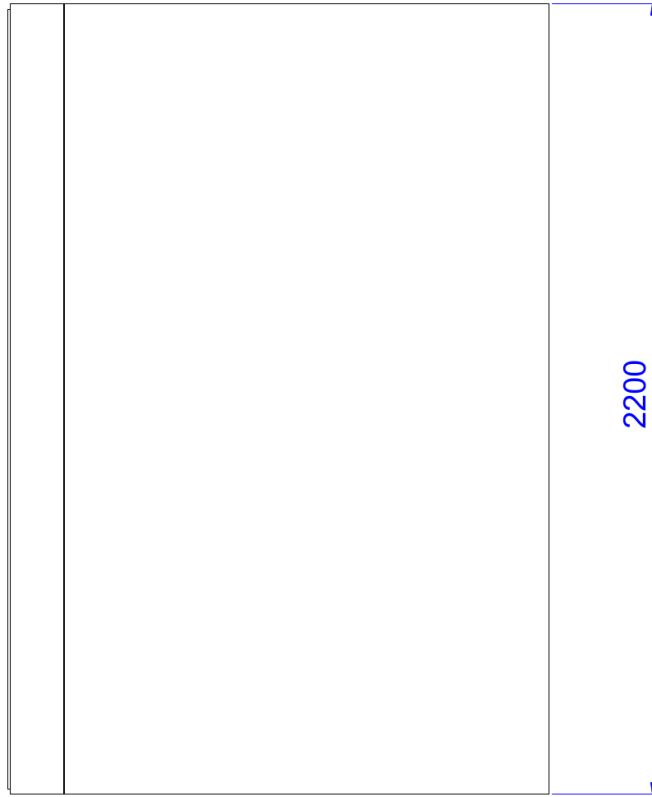
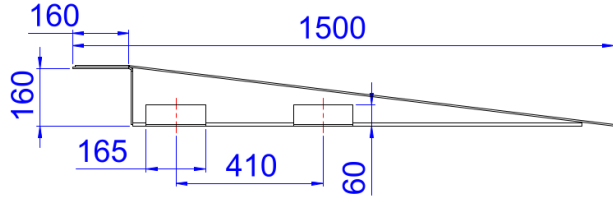

ADI - SOYADI NAME - SURNAME	TARİH DATE	İMZA SIGN	MİKTAR QUANTITY	AĞIRLIK (KG) WEIGHT (KG)	MALZEME MATERIAL	SAYFA NO PAGE NO
ŞEHİN DESIGNED BY	N.HATİPOĞLU 25/08/2021		---	230		1/1
KONTROL CONTROL	H.CANSEVER 25/08/2021					
ONAY APPROVAL	A.HEPBİLDİ 25/08/2021					
ÖLÇEK SCALE	1:9					
PARÇA/MONTAJ ADI PART/ASSEMBLY NAME			TEKNİK RESİM AÇIKLAMASI DRAWING DESCRIPTION		RESİM NO DRAWING NO	
			CLR-2215		---	



AZ MACHINERY - SLU, Matériels d'Élévation et Manutention
13 rue de la scierie - 66340 PALAISEAU - FRANCE
Téléphone : +33 (0) 37 46 100 - contact@az-machinery.com - www.az-machinery.com
Site : S24-654-958-000 19 - TVA : FR02 S24-654-958 - N° EORI : FRAD S24-654-958

7
6

Dikkat 1- Resim üzerinden ölçü aleti ile ölçü almayın. 2- Formu veya ölçüsü değişen resimleri teknik büroya bildirin. 3- Resim üzerinde kontrol edenden başkası değişiklik yapamaz.

Dosya adı: CLR-2215

SON KAYIT TARİHİ: 25 Haziran 2021 Cuma 22:04:01

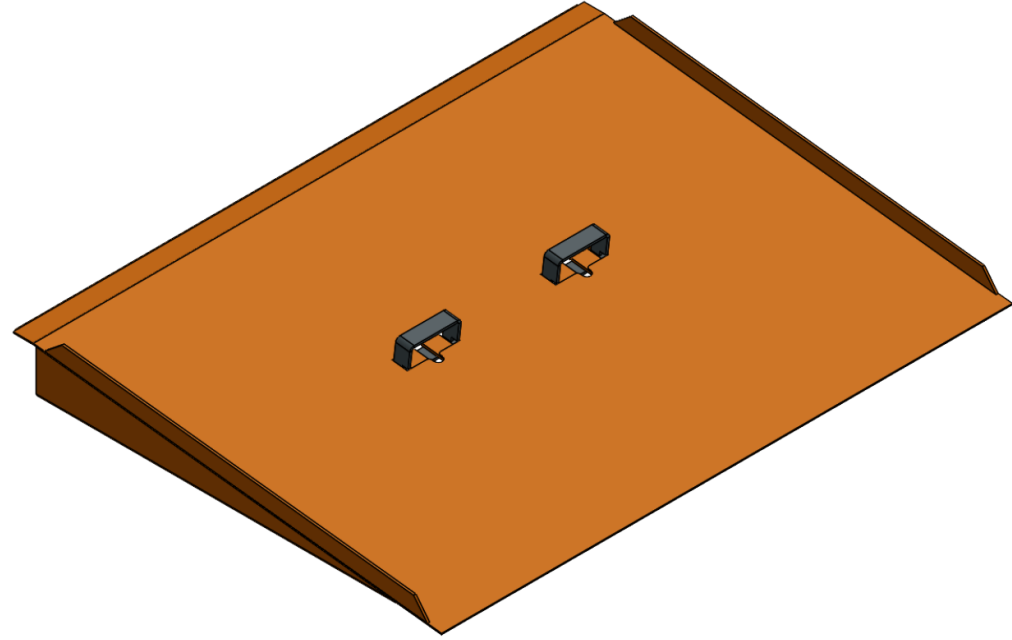
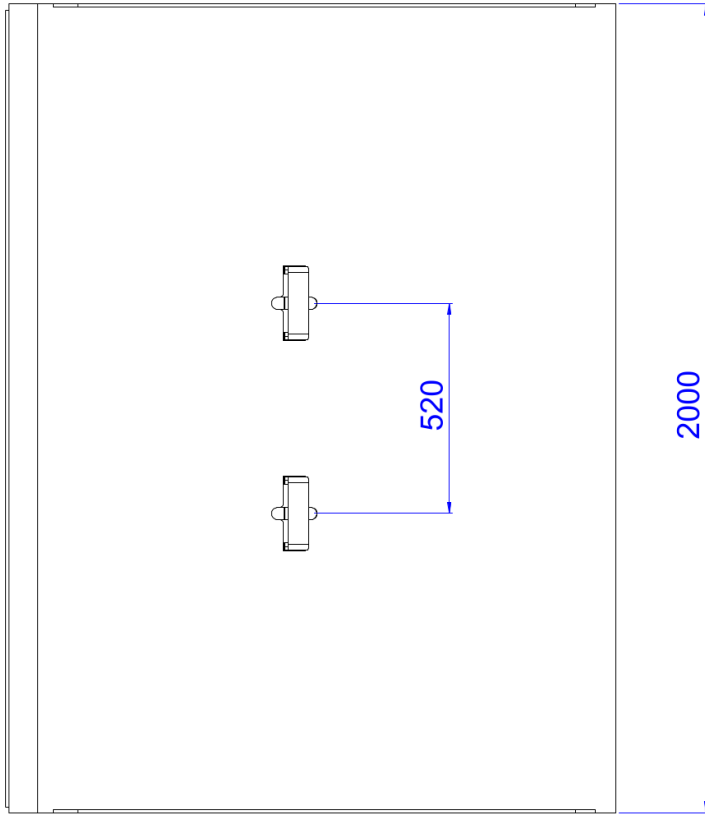
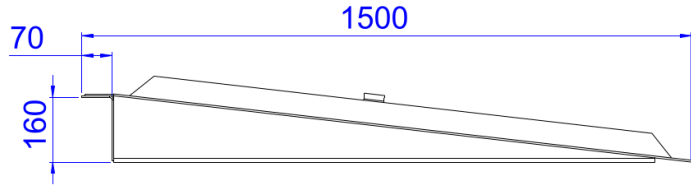

ADI - SOYADI NAME - SURNAME	TARİH DATE	İMZA SIGN	MİKTAR QUANTITY	AĞIRLIK (KG) MASS (KG)	MALZEME MATERIAL	SAYFA NO PAGE NO
ŞEHİN DESIGNED BY N.HATİPOĞLU	25/08/2021		---	280		1/1
KONTROL CONTROL H.CANSEVER	25/08/2021					
ONAY APPROVAL A.HEPBİLDİ	25/08/2021					
ÖLÇEK SCALE 1:8						
PARÇA MONTAJ ADI PART ASSEMBLY NAME			TEKNİK RESİM AÇIKLAMASI DRAWING DESCRIPTION		RESİM NO DRAWING NO	
			CLR-2015		---	



AZ MACHINERY - SLU, Matériels d'Élévation et Manutention
13 rue de la vicairie - 66340 PÉRALAS DE CÉRÉACENS - France
Téléphone : +33 37 27 46 100 - contact@az-machinery.com - www.az-machinery.com
Site : 324 654 958 000 10 - TVA : FR02 824 654 958 - N° EORI : FR02 824 654 958

7
7

Dikkat 1- Resim üzerinden ölçü aleti ile ölçü almayın. 2- Formu veya ölçüsü değişen resimleri teknik büroya bildirin. 3- Resim üzerinde kontrol edenden başkası değişiklik yapamaz.

Dosya adı: CLR-2015

SON KAYIT TARİHİ: 25 Haziran 2021 Çizim 23:16:41

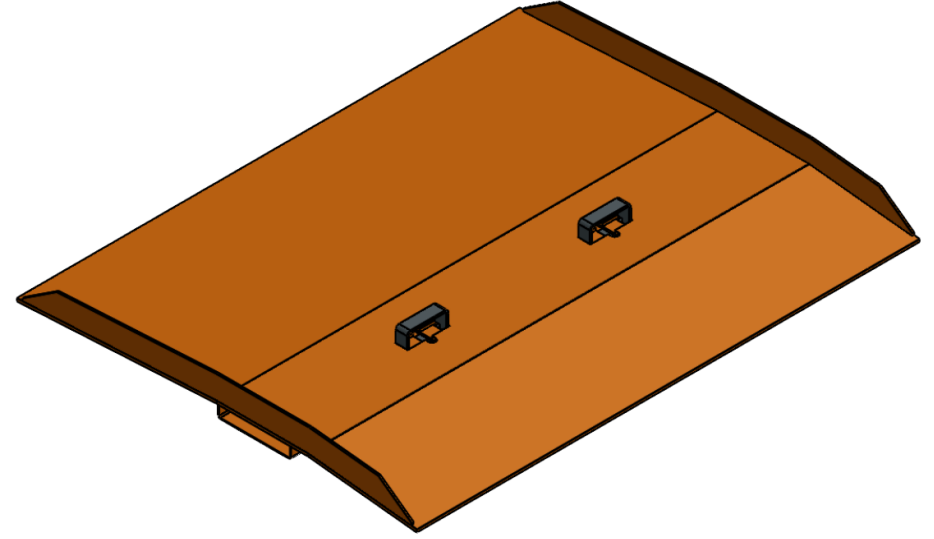
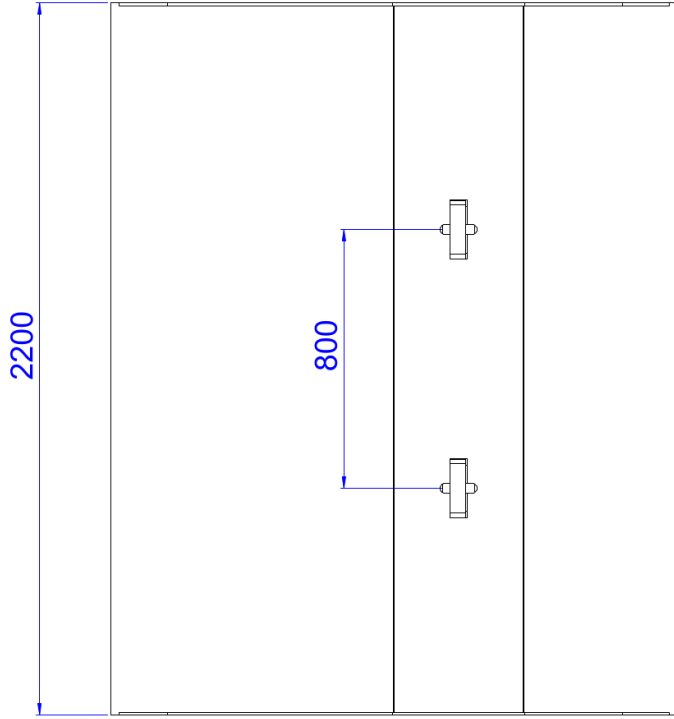
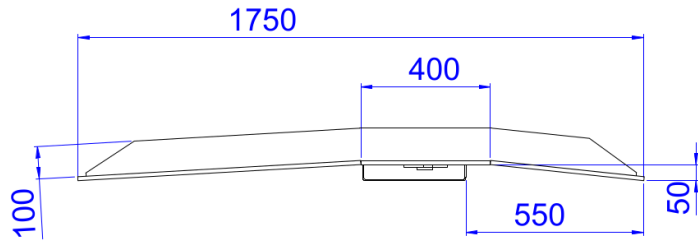

ADL - SOYADI NAME - SURNAME	TARİH DATE	İMZA SIGN	MİKTAR QUANTITY	AĞIRLIK (KG) WEIGHT (KG)	MALZEME MATERIAL	SAYFA NO PAGE NO
ŞEHİN SHAHİN	25/08/2021		---	430		1/1
KONTROL CONTROL	H.CANSEVER	25/08/2021				
ONAY APPROVAL	A.HEPBİLDİ	25/08/2021				
ÖLÇEK SCALE	1:10					
PARÇA/MONTAJ ADI PART/ASSEMBLY NAME			TEKNİK RESİM AÇIKLAMASI DRAWING DESCRIPTION			RESİM NO DRAWING NO
			CLR-2017			---



AZ MACHINERY - SLU, Matériels d'Élévation et Manutention
13 rue de la vicairie - 06 340 PALAISEAU DE CERÉACRENS - France
Téléphone : +33 (0) 27 46 100 - contact@az-machinery.com - www.az-machinery.com
Site : 024 654 958 000 19 - TVA : FR02 824 654 958 - N° EORI : FR02 824 654 958

7
8

Dikkat 1- Resim üzerinden ölçü aleti ile ölçü almayın. 2- Formu veya ölçüsü değişen resimleri teknik büroya bildirin. 3- Resim üzerinde kontrol edenden başkası değişiklik yapamaz.

Dosya adı: CLR-2217

SON KAYIT TARİHİ: 25 Haziran 2021 Cuma 22:48:21

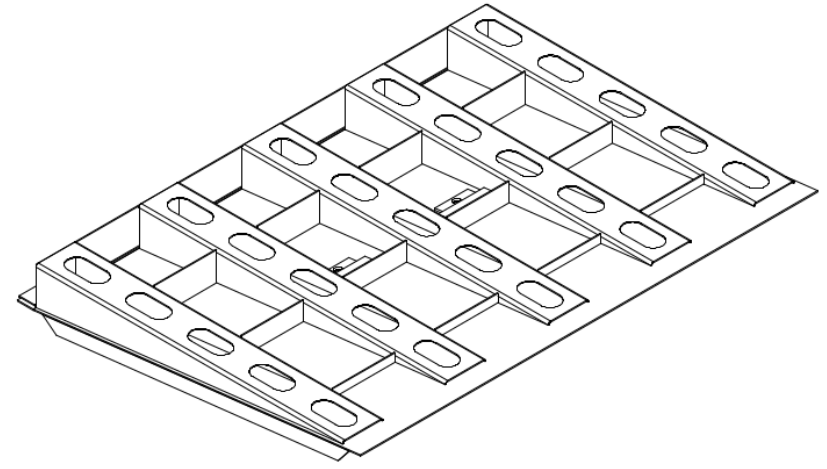
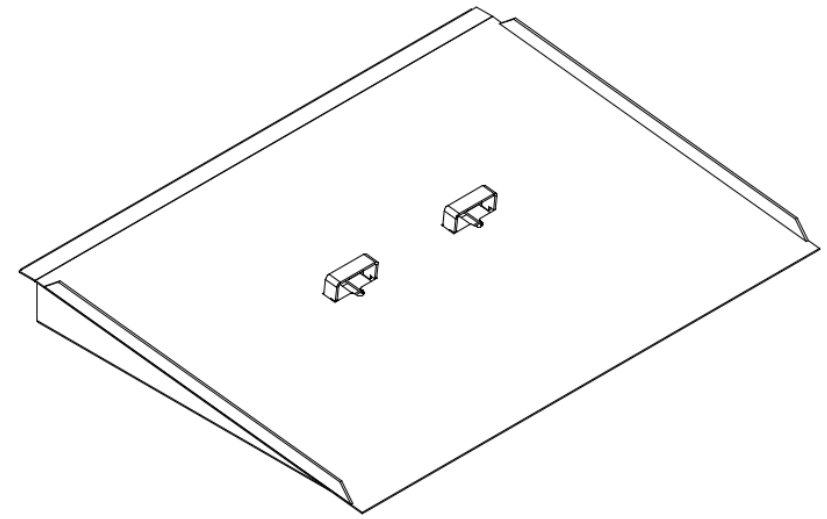
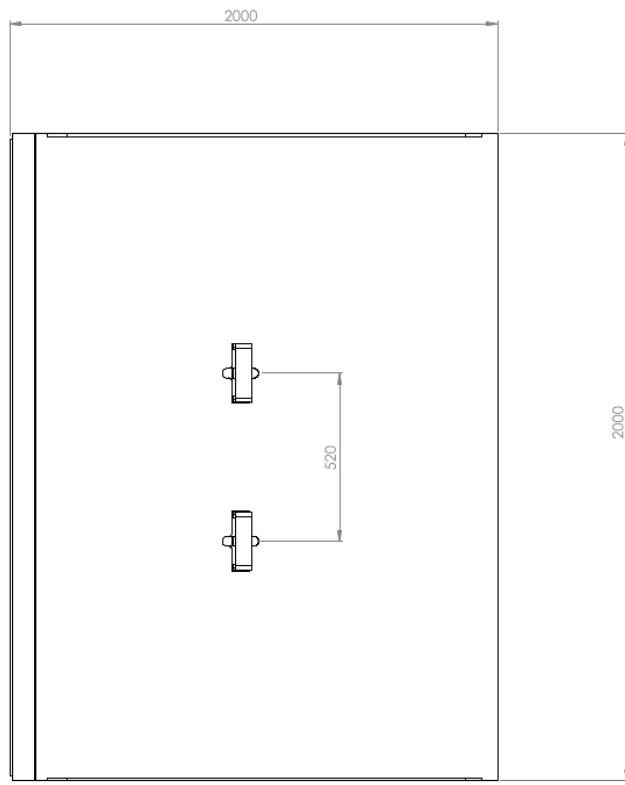
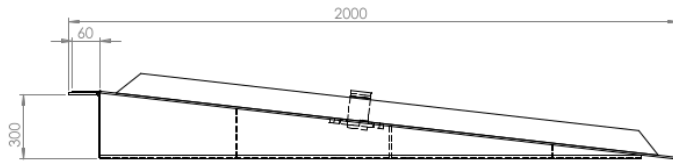

NAME - SURNAME	DATE	SIGN	QUANTITY	MASS (KG)	MATERIAL	PROCESS
DRAWN BY: N.HATIPOGLU	---	---	---	---	---	1/1
CONTROL: H.CANSEVER	---	---	---	---	---	---
APPROVAL: K.TEKIN	---	---	---	---	---	---
SCALE: 1:20	---	---	---	---	---	---
PART/ASSEMBLY NAME	DRAWING DESCRIPTION		DRAWING NO.		---	
---	#74K7		---		---	



AZ MACHINERY - SLU, Matériels d'Élévation et Maintenance
 13 rue de la scierie - 06 540 PALAISEAU DE CERDAGNE - France
 Téléphone : +33 (0) 47 46 1001 - contact@az-machinery.com - www.az-machinery.com
 Site : S24 654 958 000 10 - TVA : FR02 824 654 958 - N° EORI : FRAD 824 654 958

12 11 10 9 8 7 6 5 4 3 2 1

H
G
F
E
D
C
B
A

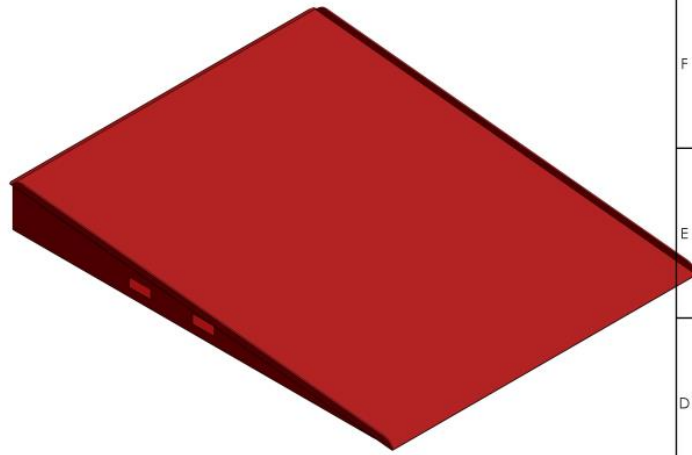
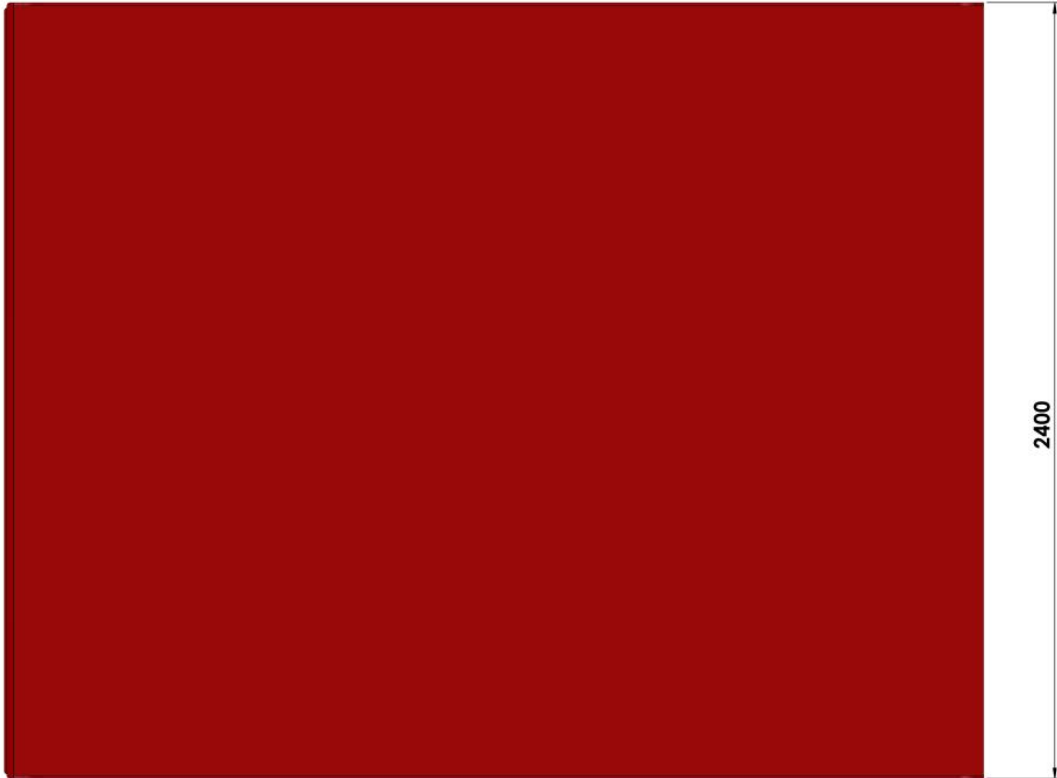
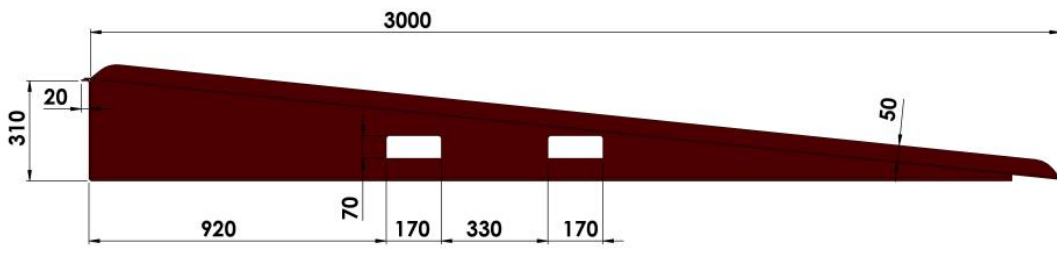

NAME - SURNAME	DATE	SIGN	QUANTITY	MASS (KG)	MATERIAL	PAGE/NT
DRAWN BY H. CANSEVER	10.12.2021		---			1/1
CONTROL A. HEPBILDI	10.12.2021					
APPROVAL S. ENTZMANN	10.12.2021					
SCALE 1:20						
PART/ASSEMBLY NAME			DRAWING DESCRIPTION		DRAWING NO.	
			#M83Y		---	



AZ MACHINERY - SLU, Matériels d'Élévation et Maintenance
 13 rue de la scierie - 66340 PALAISEAU DE CERDAGNE - France
 Téléphone : +33 37 27 46 100 - contact@az-machinery.com - www.az-machinery.com
 Site : S24 654 958 000 19 - TVA : FR02 824 654 958 - N° EORI : FR02 824 654 958

8
0

12 11 10 9 8 7 6 5 4 3 2 1

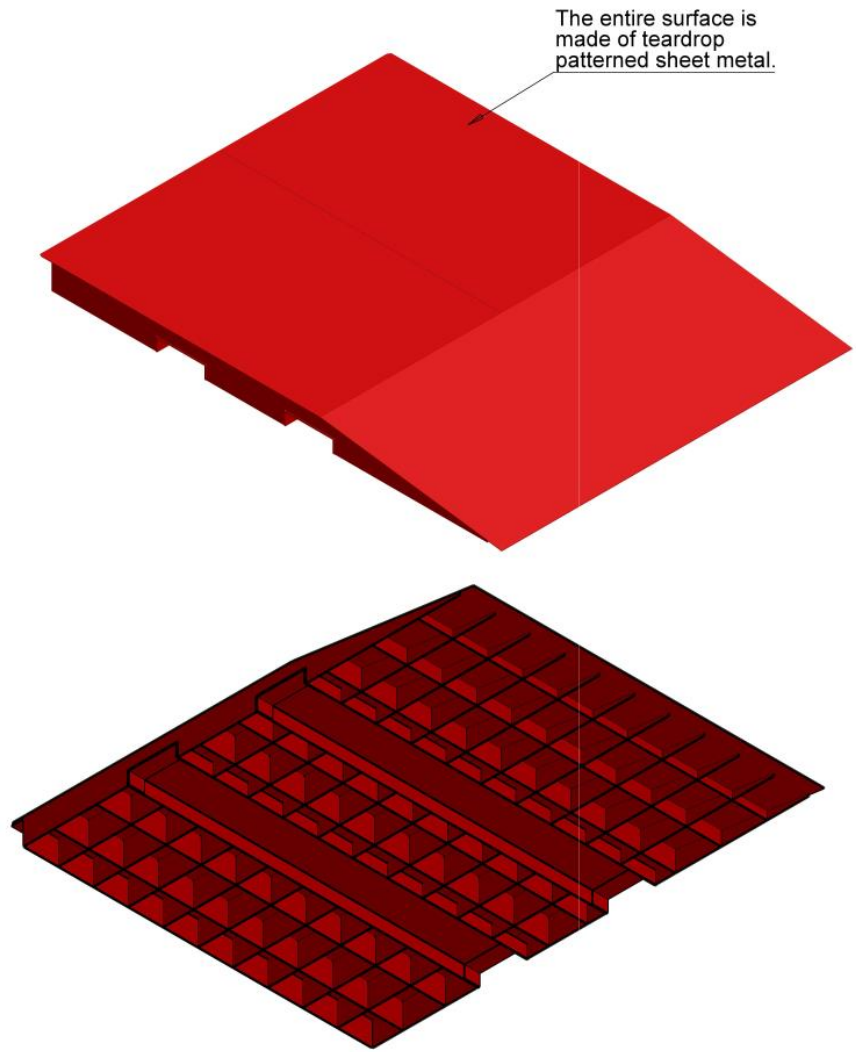
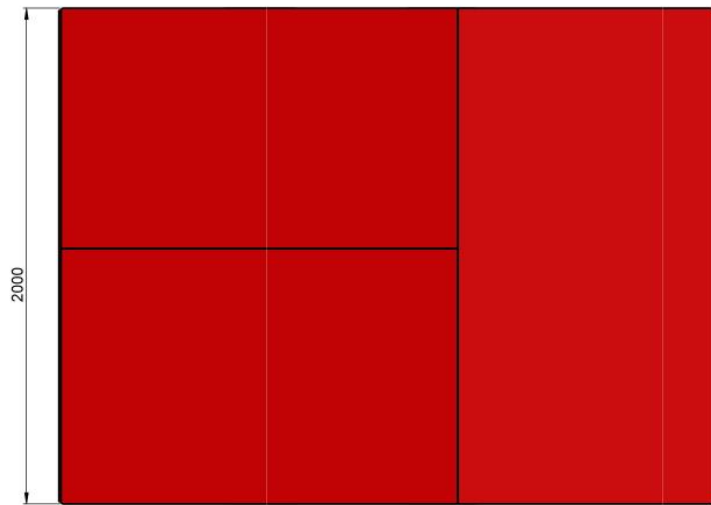
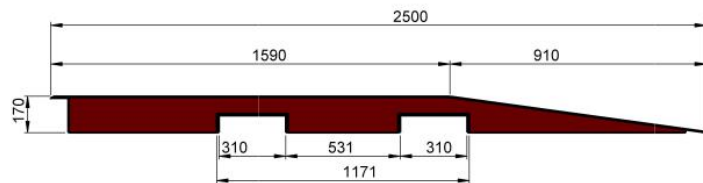

NAME - SURNAME	DATE	SIGN	QUANTITY	MASS (KG)	MATERIAL	PAGE/NT
DRAWN BY: B.QZ/FCI	31.03.2022		---			1/1
CONTROL: A.HEPBILDI	31.03.2022					
APPROVAL: J.GUQUET	31.03.2022					
SCALE: 1:20						
PART/ASSEMBLY NAME			DRAWING DESCRIPTION:		DRAWING NO.	
			#M83Y		---	

AZ MACHINERY - SLU, Matériels d'Élévation et Maintenance
 13 rue de la scierie - 05 340 PÉLASSI DE CÉRÉACRE - France
 Téléphone : +33 47 27 46 300 - contact@az-machinery.com - www.az-machinery.com
 Site : 024 654 958 000 19 - TVA : FR02 824 654 958 - N° EORI : FR02 824 654 958

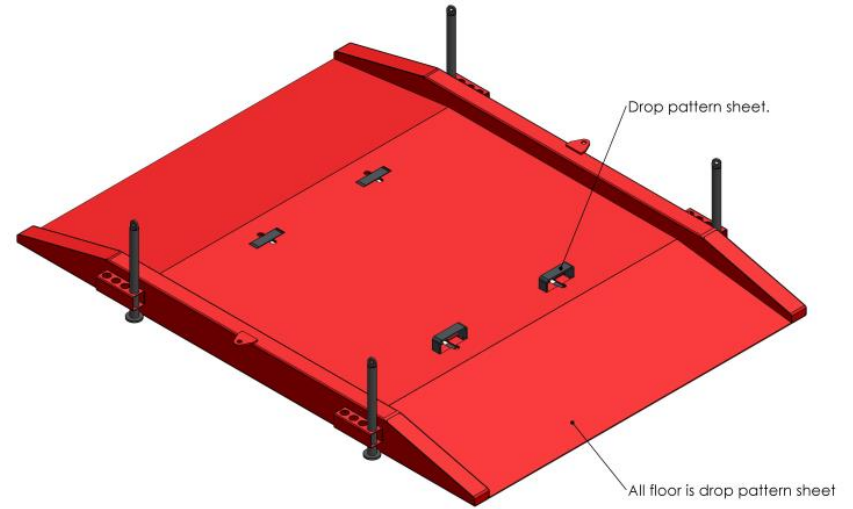
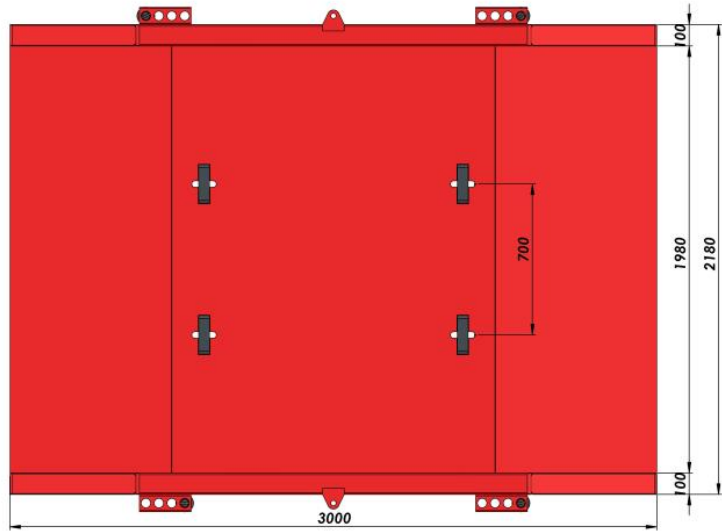
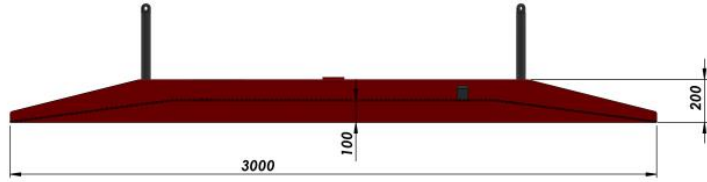

CAPACITY: 10.000 KG

NAME - SURNAME	DATE	SIGN	QUANTITY	MASS (KG)	MATERIAL	PAGE NR
DRAWN BY: H. CANSEVER	18.10.2022		---			1/1
CONTROL: A. HEPBILDI	18.10.2022					
APPROVAL: S. ENTZMANN	18.10.2022					
SCALE: 1:20						
PART/ASSEMBLY NAME			DRAWING DESCRIPTION		DRAWING NO.	
			#7N33		---	



AZ MACHINERY - SLU, Matériels d'Élévation et Manutention
 13 rue de la scierie - 66340 PÉLAGY - FRANCE
 Téléphone : +33 32 37 46 300 - contact@az-machinery.com - www.az-machinery.com
 Site : 024 654 958 000 19 - TVA : FR02 824 654 958 - N° EORI : FR02 824 654 958

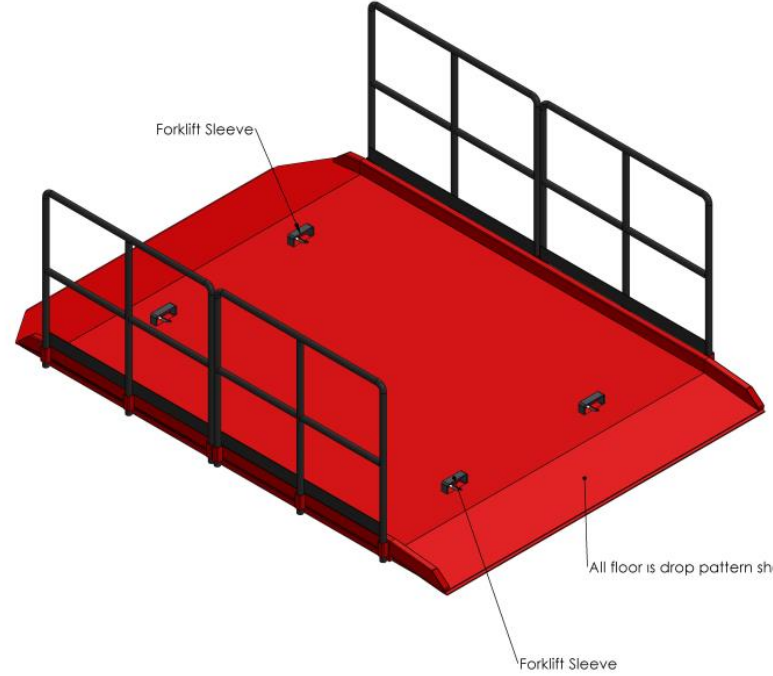
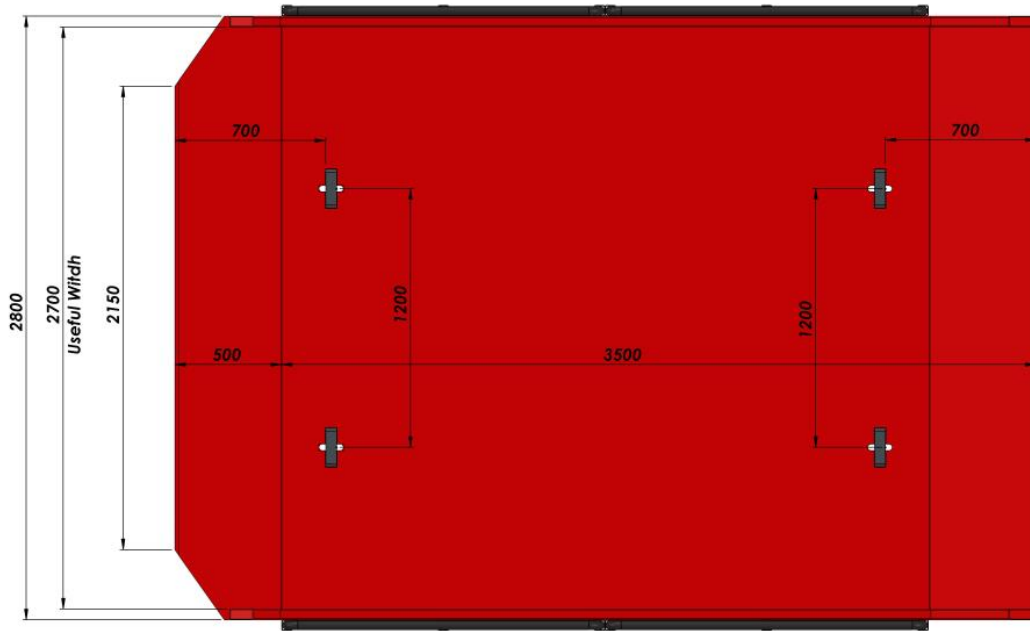
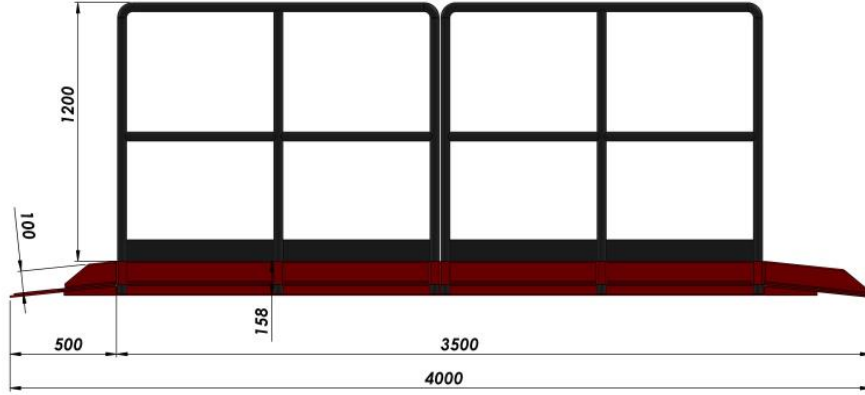

CAPACITY: 20000 KG

NAME - SURNAME	DATE	SIGN	QUANTITY	MASS (KG)	MATERIAL	PAGE NR
DRAWN BY: H. CANSEVER	18.05.2022		---			1/1
CONTROL: A. HEPBILDI	18.05.2022					
APPROVAL: S. ENTZMANN	18.05.2022					
SCALE: 1:20						
PART/ASSEMBLY NAME	DRAWING DESCRIPTION:		DRAWING NO.			
	#7N33		---			



DRAWINGS

- Rampes mobiles
- Rampes fixes
- Plateformes logistiques
- Rampes de quai
- Réhausse
- Tables de quai mobiles
- Tables de quai fixes
- Passerelles
- Rampes pour conteneurs
- Niveleurs
- Fournitures de quai

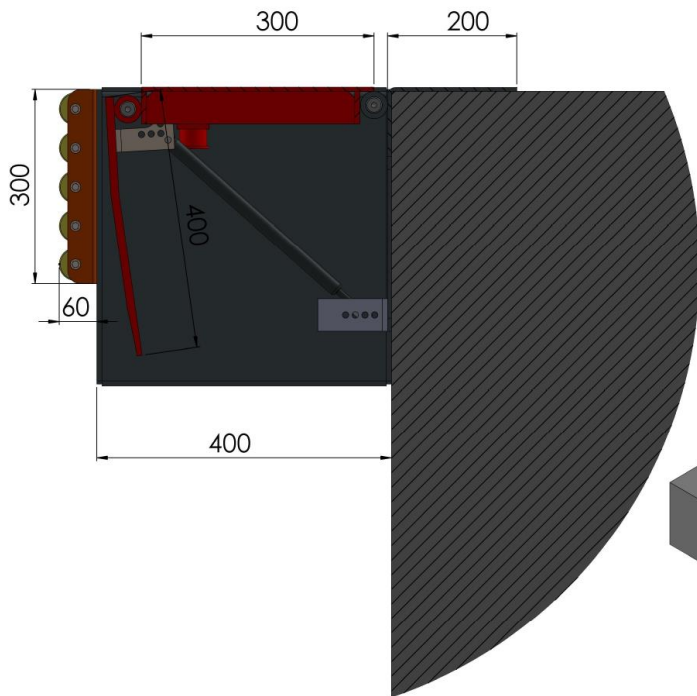
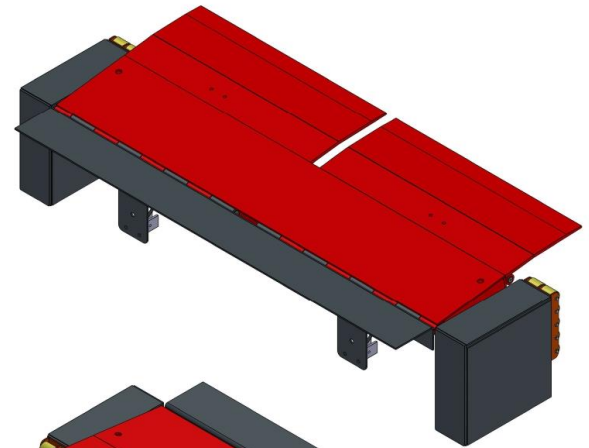
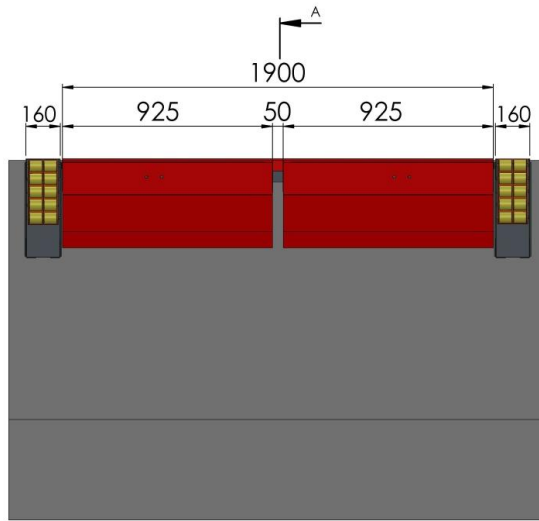
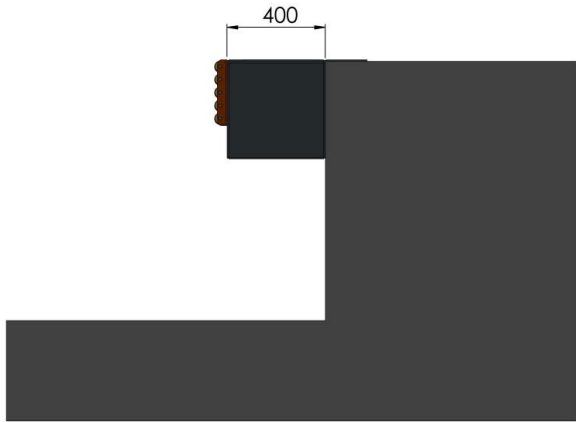

LIPSARE TWO PIECE

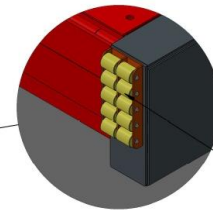
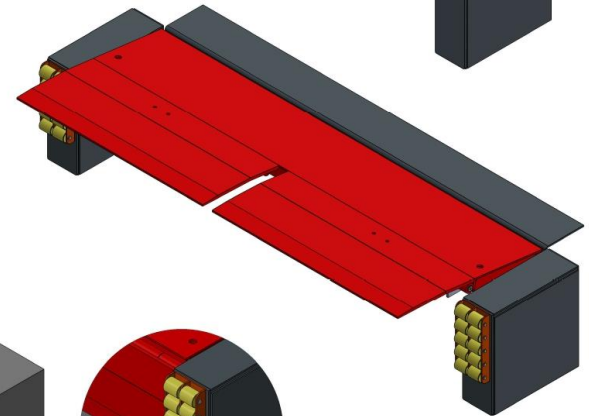
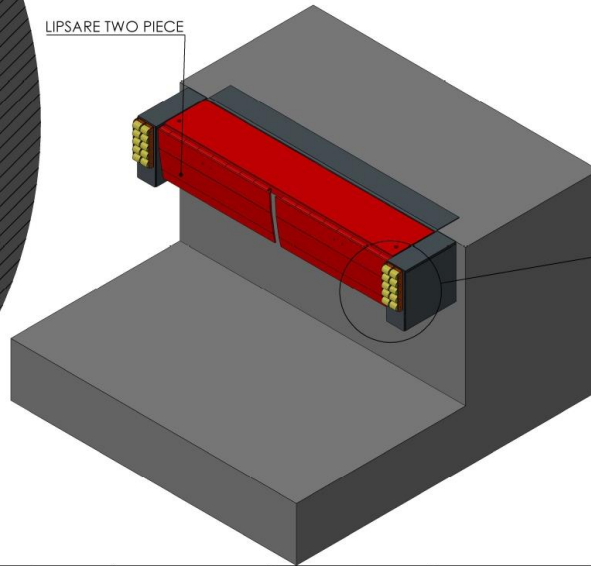

WHEELED BUMPER

DETAIL B
SCALE 1 : 10

NAME - SURNAME	DATE	SIGN	QUANTITY	MASS (KG)	MATERIAL	PAGE NR
DRAWN BY H. CANSEVER	---	---	---			1/1
CONTROL N. HATIPOGLU	---	---				
APPROVAL A. HEPBILDI	---	---				
SCALE 1:20						
PART/ASSEMBLY NAME		DRAWING DESCRIPTION		DRAWING NO		
		#MA8N		---		



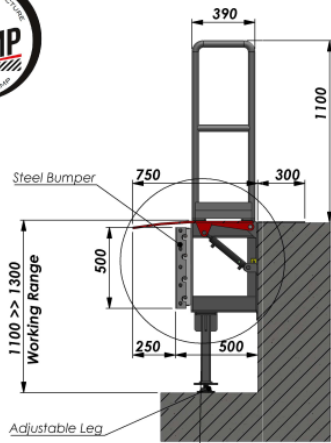

SECTION A-A

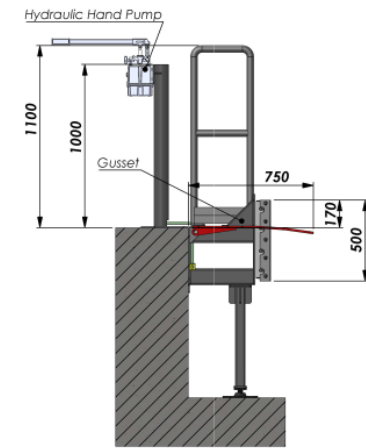
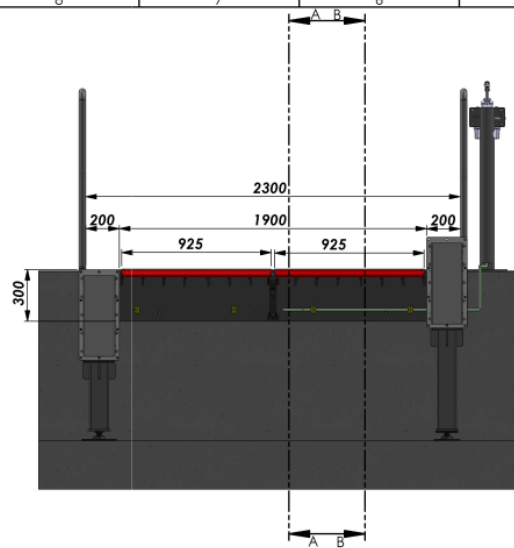

SECTION B-B

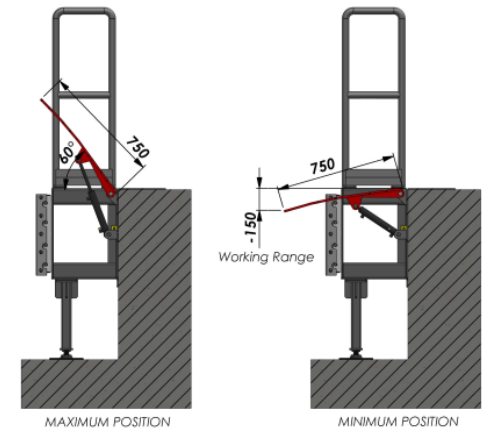
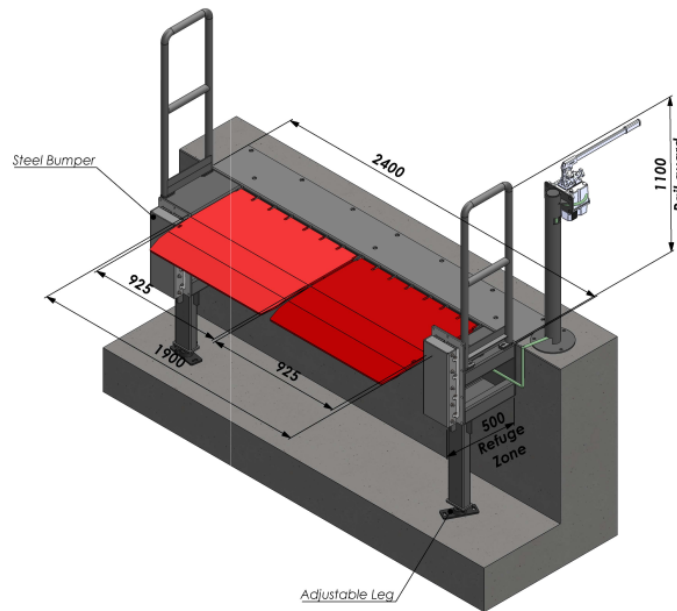
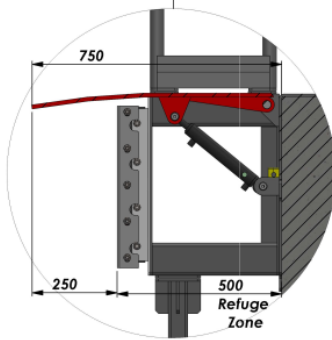

NAME (SURNAME)	DATE	SIGN	QUANTITY	MASS (KG)	MATERIAL	PAGE/HR
B. OZCIPCI	15.11.2023		---			1/1
H. CANSEVER	15.11.2023					
S. ENTZMANN	15.11.2023					
SCALE	1:20					
PART/ASSEMBLY NAME	DRAWING DESCRIPTION		DRAWING NO.			
	DTC Hydraulic Lips Mini Levelers		---			



AZ MACHINERY - SLU, Matériels d'Élévation et Maintenance
 13 rue de la scierie - 46 340 PALLATI DE CERDIGNON - France
 Téléphone : +33 (0) 27 48 500 - contact@az-machinery.com - www.az-machinery.com
 Site : 824 654 958 600 19 - TVA : FR02 824 654 958 - N° EORI : FR02 824 654 958

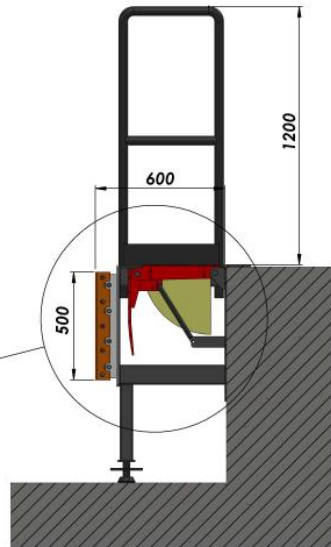
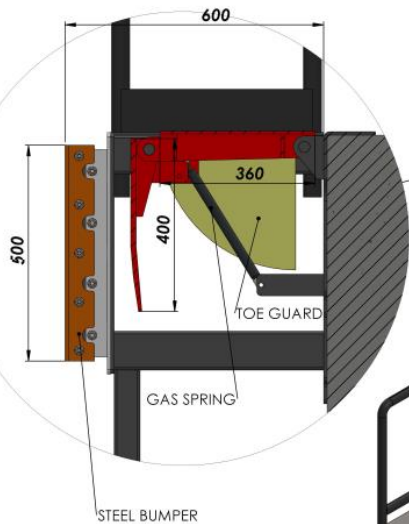

SECTION A-A
SCALE 1 : 15

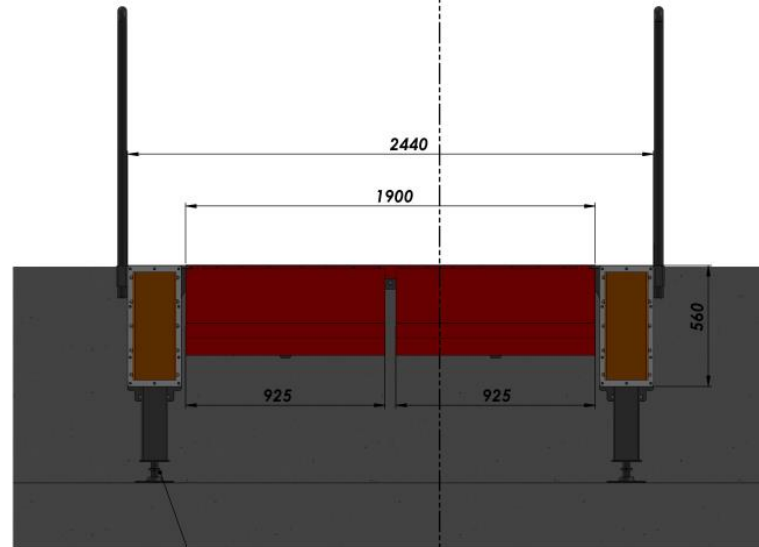

ADJUSTABLE LEG

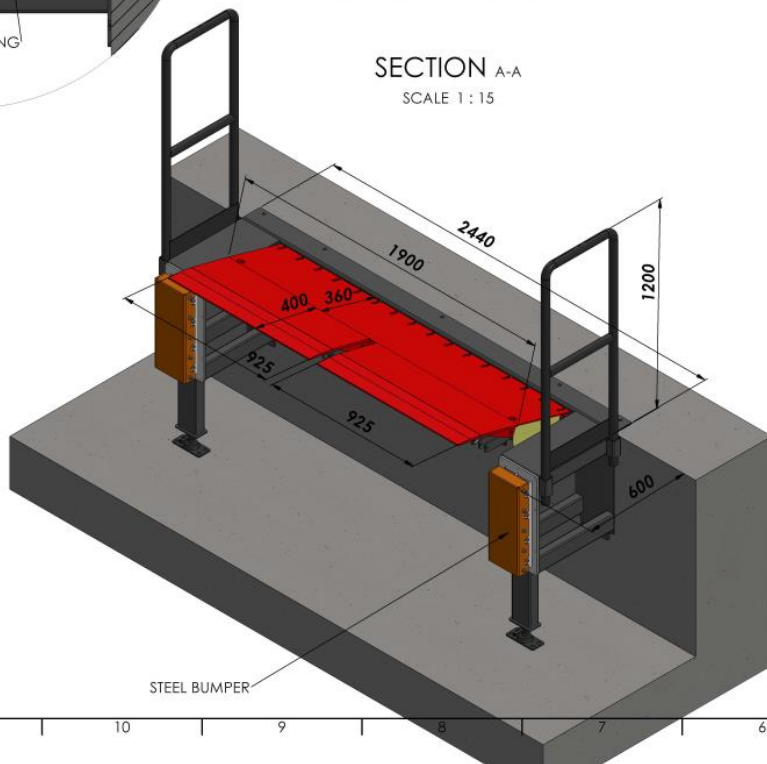

STEEL BUMPER

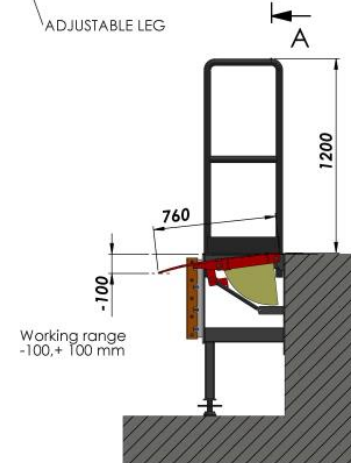

Working range
-100,+ 100 mm

NAME -SURNAME	DATE	SIGN	QUANTITY	MASS (KG)	MATERIAL	PAGE/NT
DRAWN BY: H. CANSEVER	19.04.2022		---			1/1
CONTROL: A. HEPBILDI	19.04.2022					
APPROVAL: S. ENTZMANN	19.04.2022					
SCALE: 1:20						
PART/ASSEMBLY NAME	DRAWING DESCRIPTION:		DRAWING NO.			
	#6ZW2 Manual Mini leveler		---			



AZ MACHINERY - SLU, Matériels d'Élévation et Manutention
13 rue de la source - 36 340 PILLATI DE CIEBACQNE - France
Téléphone : 03 35 27 46 500 - contact@az-machinery.com - www.az-machinery.com
Site : 424 654 958 666 19 - TVA : FR02 824 654 958 - N° EORI : FR02 824 654 958

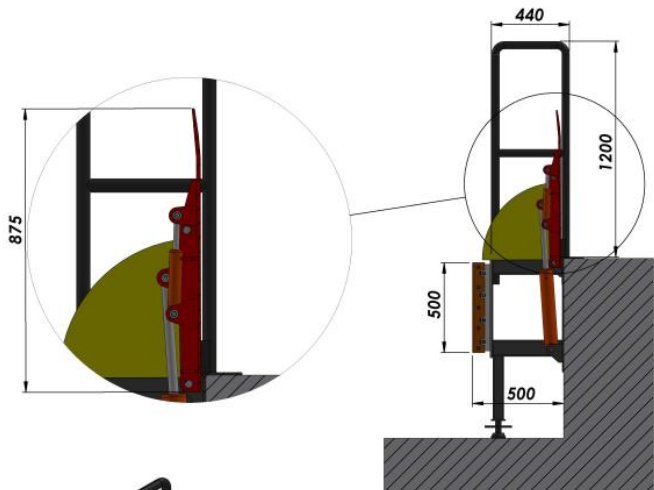

SECTION A-A
SCALE 1 : 18

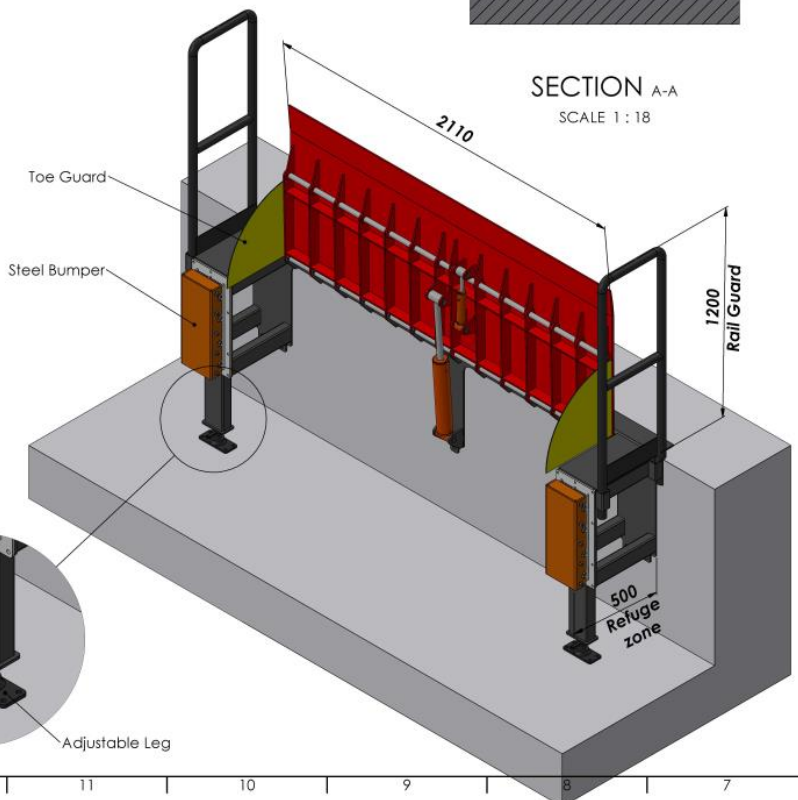
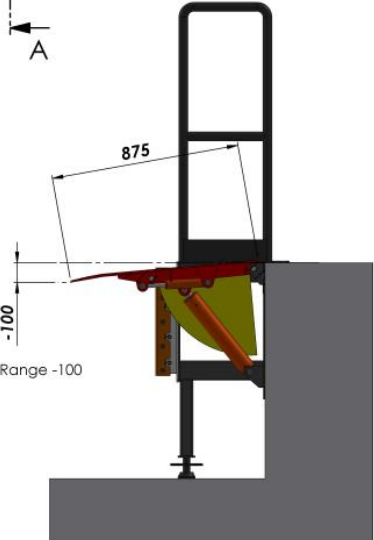
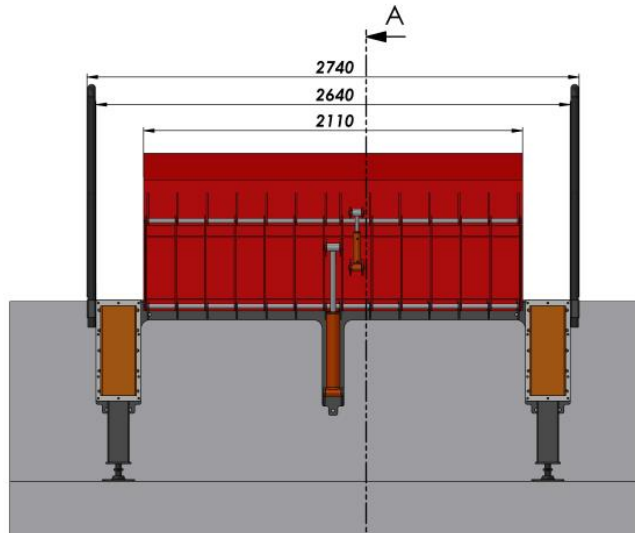

NAME - SURNAME	DATE	SIGN	QUANTITY	MASS (KG)	MATERIAL	PAGE NR
DRAWN BY H. CANSEVER	10.03.2022		---			1/1
CONTROL A. HEPBILDI	10.03.2022					
APPROVAL S. ENTZMANN	10.03.2022					
SCALE 1:50						
PART/ASSEMBLY NAME	DRAWING DESCRIPTION		DRAWING NO.			
	#E4EE		---			



AZ MACHINERY - SLU, Matériels d'Élévation et Manutention
 13 rue de la scierie - 66340 PALATRI DE CERDAGNE - France
 Téléphone : +33 (0) 37 48 500 - contact@az-machinery.com - www.az-machinery.com
 Site : 424 654 958 (FR) TVA : FR02 824 654 958 - N° EORI : FR02 824 654 958

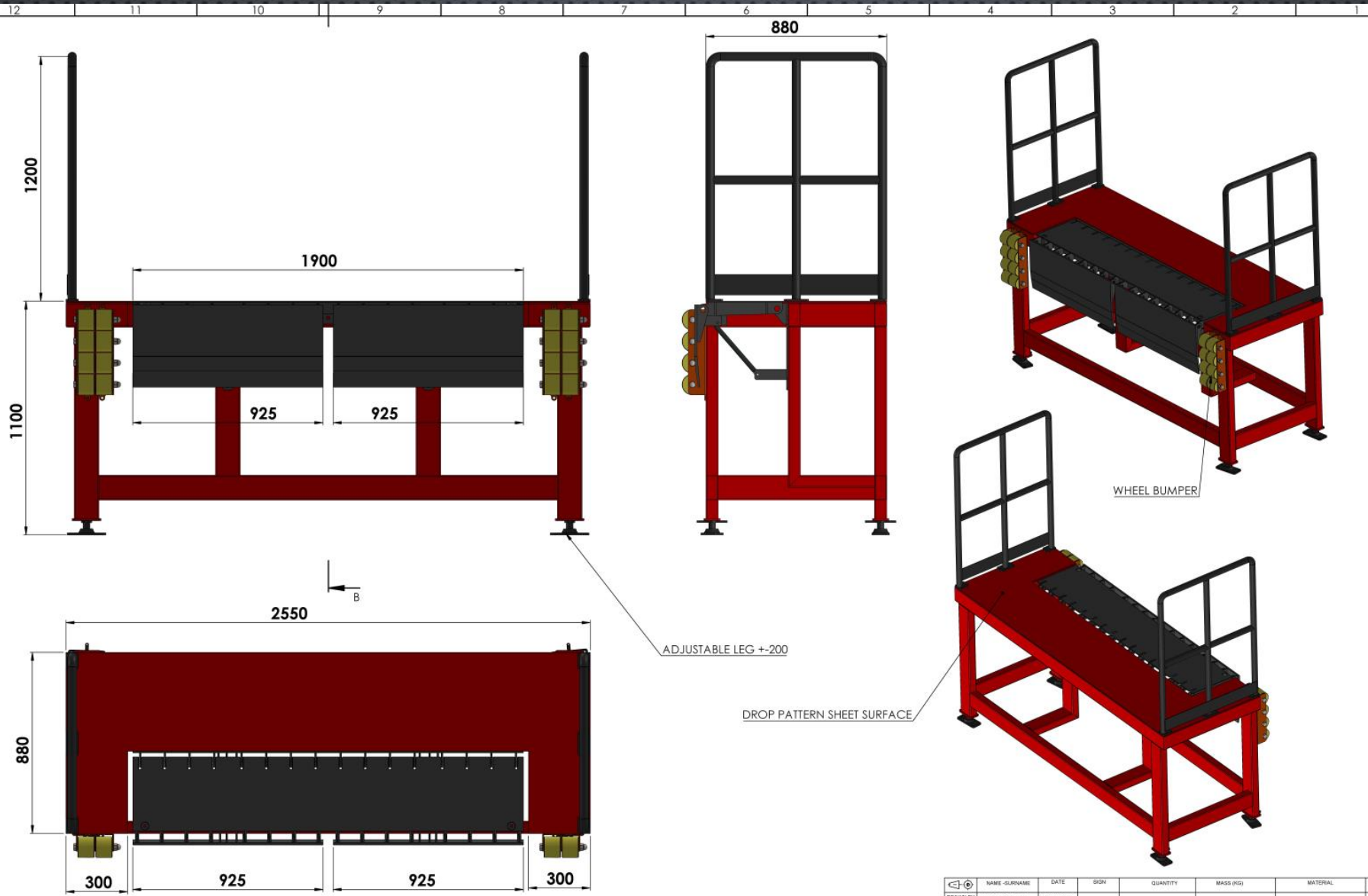

NAME - SURNAME	DATE	SIGN	QUANTITY	MASS (KG)	MATERIAL	PAGE/NT
DRAWN BY: H. CANSEVER	19.10.2021		---			1/1
CONTROL: A. HEPBILDI	19.10.2021					
APPROVAL: S. ENTZMANN	19.10.2021					
SCALE: 1:20						
PART/ASSEMBLY NAME	DRAWING DESCRIPTION:		DRAWING NO.			
	PLATFORM WITH MANUEL EDGE DOCK LEVELER		---			

AZ MACHINERY
 AZ MACHINERY - SLU, Matériels d'Élévation et Manutention
 13 rue de la scierie - 46 340 PALLATI DE CERBACHON - France
 Téléphone : 03 53 27 48 500 - contact@az-machinery.com - www.az-machinery.com
 Site : 424 654 958 660 FR - TVA : FR02 824 654 958 - 3° EDI 001 - FR03 824 654 958

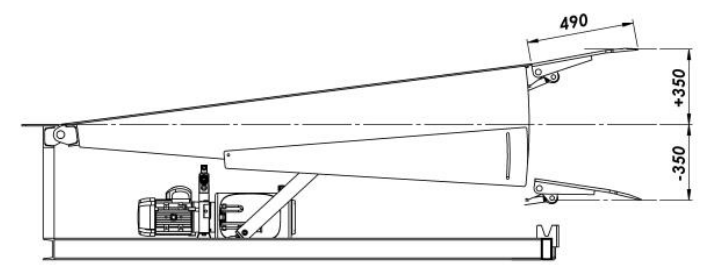
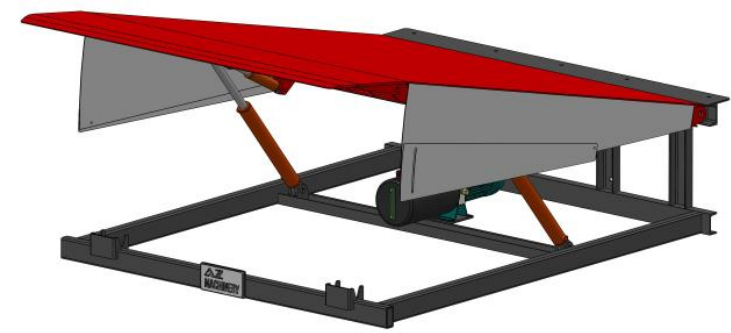
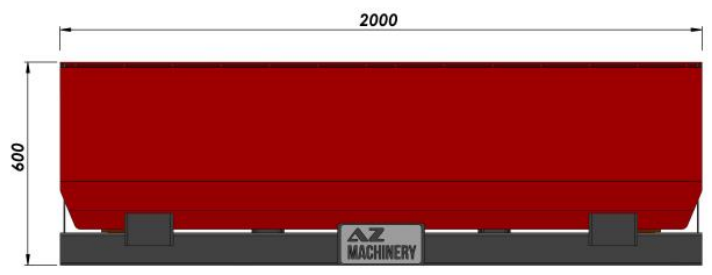
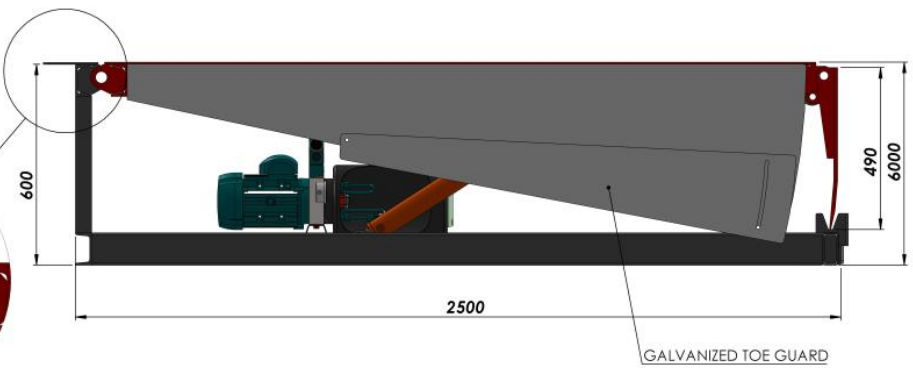

NAME (SURNAME)	DATE	SIGN	QUANTITY	MASS (KG)	MATERIAL	PAGE (NR)
DRAWN BY: H. CANSEVER	01.02.2022		---			1/1
CONTROL: A. HEPBILDI	01.02.2022					
APPROVAL: S. ENTZMANN	01.02.2022					
SCALE: 1:20						
PARTS/ASSEMBLY NAME	DRAWING DESCRIPTION:		DRAWING NO.			
	2000X2500_490 HINGED LIP DOCK LEVELER		---			



AZ MACHINERY - SLU, Matériels d'Élévation et Maintenance
 13 rue de la scierie - 66340 PALLAS DE CERDAGNE - France
 Téléphone : +33 (0) 27 48 300 - contact@az-machinery.com - www.az-machinery.com
 Site : 624 654 958 (FR) - TVA : FR02 624 654 958 - N° EORI : FR02 624 654 958

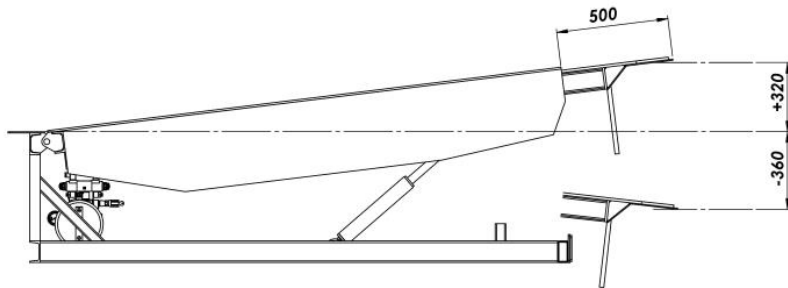
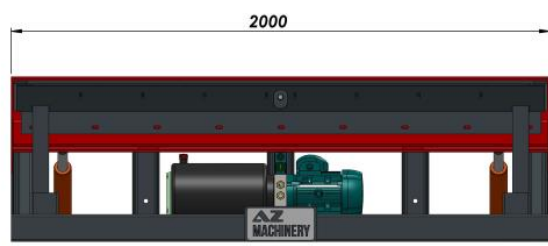
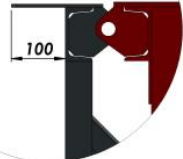
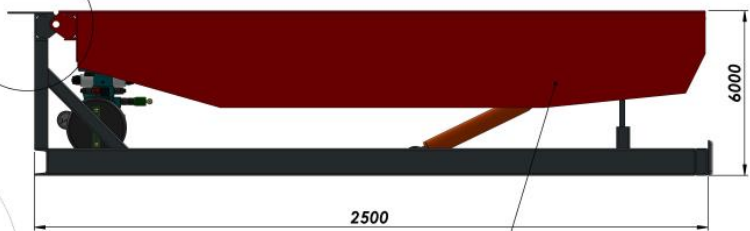

NAME - SURNAME	DATE	SIGN	QUANTITY	MASS (KG)	MATERIAL	PAGE/NO
DRAWN BY: H. CANSEVER	01.02.2022		---			1/1
CONTROL: A. HEPBILDI	01.02.2022					
APPROVAL: S. ENTZMANN	01.02.2022					
SCALE: 1:20						
PART/ASSEMBLY NAME			DRAWING DESCRIPTION		DRAWING NO.	
			2000x2500...500 TELESCOPIC DOCK LEVELER		---	



AZ MACHINERY - SLU, Matériels d'Élévation et Maintenance
 13 rue de la scierie - 86 340 PALAIS DE CERAMIQUE - France
 Téléphone : +33 (0) 27 48 500 - contact@az-machinery.com - www.az-machinery.com
 Site : AZ 654 958 666 FR - TVA : FR02 824 654 958 - N° EORI : FR02 824 654 958

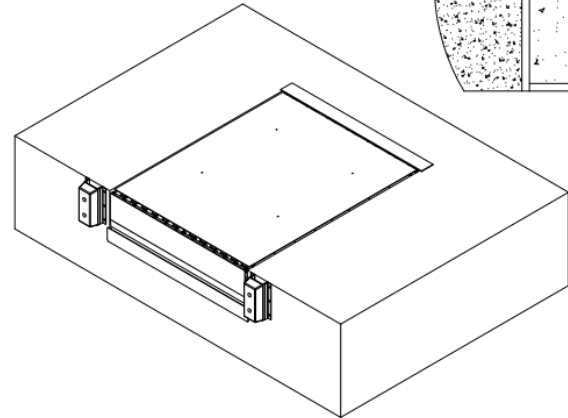
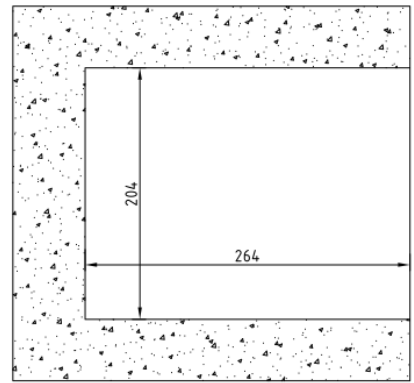
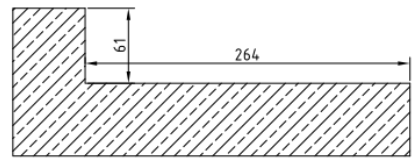
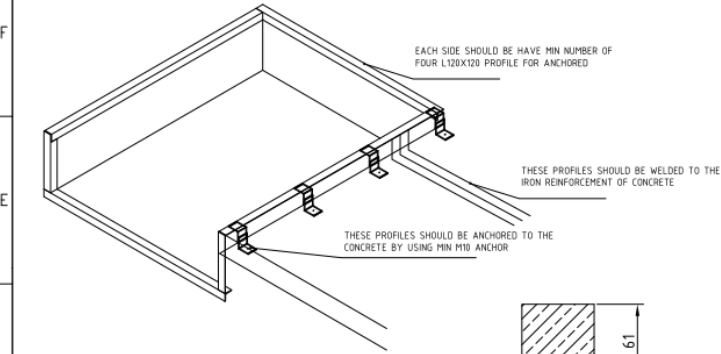
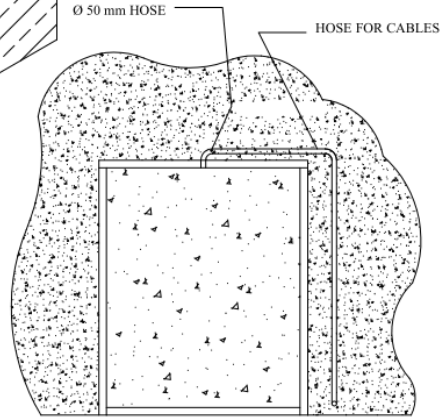
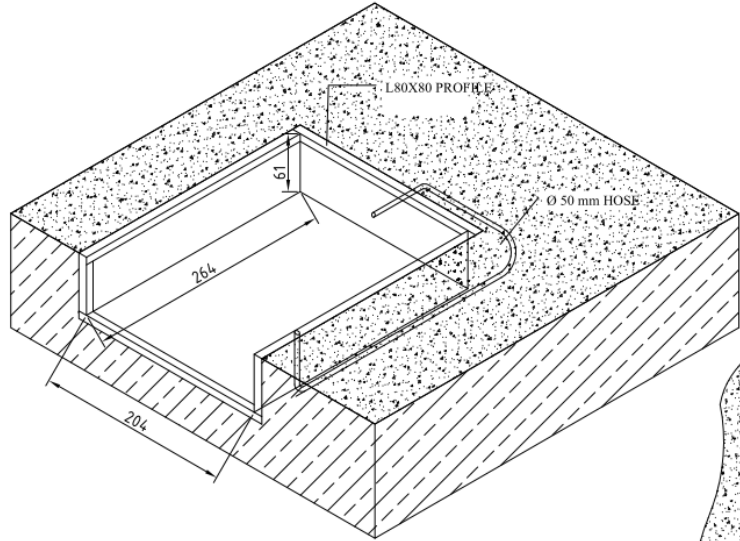
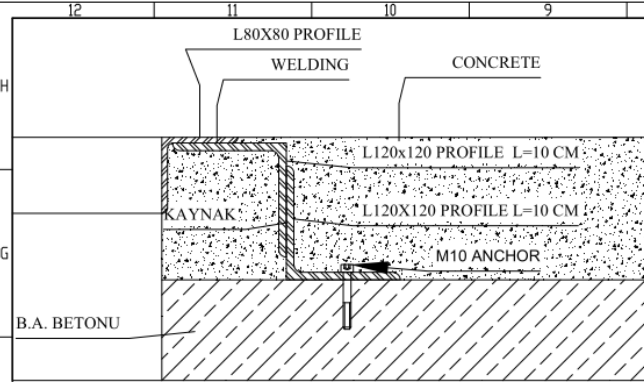

NOTE: ALL DIMENSIONS ARE IN CM

NAME - SURNAME	DATE	SIGN	QUANTITY	MASS (KG)	MATERIAL	page:nb
DRAWN BY H. CANSEVER	19.10.2021		---			1/1
CONTROL A. HEPBILDI	19.10.2021					
APPROVAL S. ENTZMANN	19.10.2021					
SCALE 1:20						
PARTASSEMBLY NAME		DRAWING DESCRIPTION			DRAWING NO	
		HINGED LIP DOCK LEVELER LAYOUT			---	



AZ MACHINERY - SLU, Matériels d'Élévation et Manutention
13 rue de la science - 68 300 PALAZZ DE CEREMANNI - France
Téléphone : +33 33 27 40 360 contact@az-machinery.com www.az-machinery.com
Site: 824 654 108 000 FR - TVA : FR02 824 654 108 - N° EORI: FR023 025 654 108

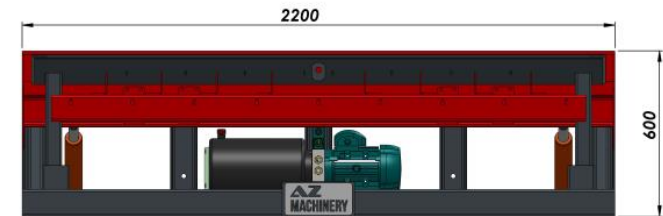
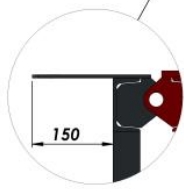
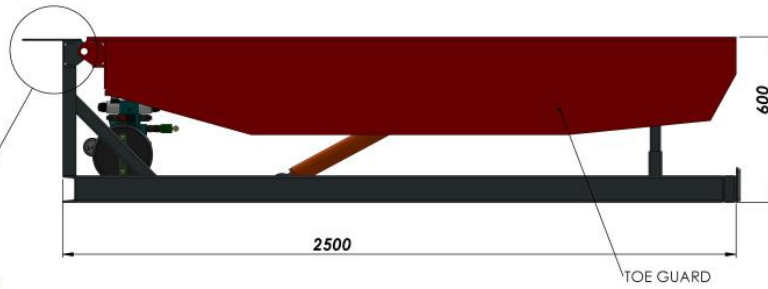

HOLES FOR ANCHORING

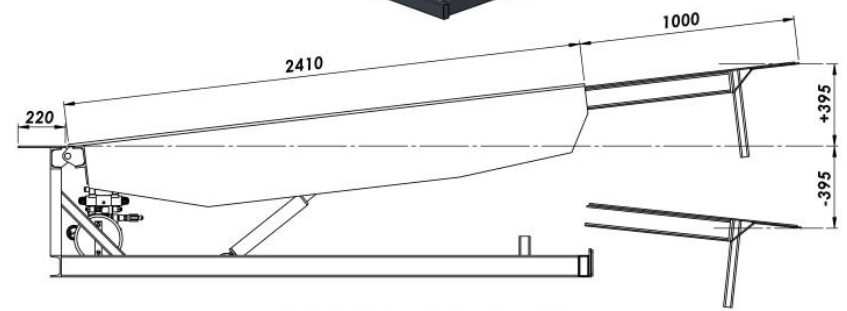

- TELESCOPIC LIP DOCK LEVELER FEATURES**
- 1- Working range: -395 / +395 mm and flap length: 1000 mm
 - 2- CE Certificate and compatible design with EN 1398 and ANSI MH30.2
 - 3- Platform floor made of teardrop pattern plates
 - 4- Flap is made of strengthened teardrop pattern plates
 - 5- Heavy load capacity hinge system for maximum resistance to moving load
 - 6- Side protection plates conforming to safety standards
 - 7- Maximum operating slope 12.5% (7°) for work and worker safety
 - 8- Platform floor is lifted with double hydraulic piston for high safety
 - 9- Hydraulic emergency declaration mechanism
 - 10- Electro-hydraulic system with IP65 protection class control panel
 - 11- Security lock for maintenance
 - 12- 450x200x100 mm dimensions and 70 Shore side bumpers

NAME (SURNAME)	DATE	SIGN	QUANTITY	MASS (KG)	MATERIAL	PAGE NR
DRAWN BY: H. CANSEVER	10.06.2022		---			1/1
CONTROL: A. HEPBILDI	10.06.2022					
APPROVAL: S. ENTZMANN	10.06.2022					
SCALE: 1:20						
PARTS/ASSEMBLY NAME			DRAWING DESCRIPTION			DRAWING NO.
			#K659			9 3



AZ MACHINERY - SLU, Matériels d'Élévation et Maintenance
 13 rue de la scierie - 36340 PALLATI DE CERDIGNY - France
 Téléphone : +33 (0) 27 46 500 - contact@az-machinery.com - www.az-machinery.com
 Site : 424 654 958 666 19 - TVA : FR02 824 654 958 - 3° ED08 - FR03 824 654 958

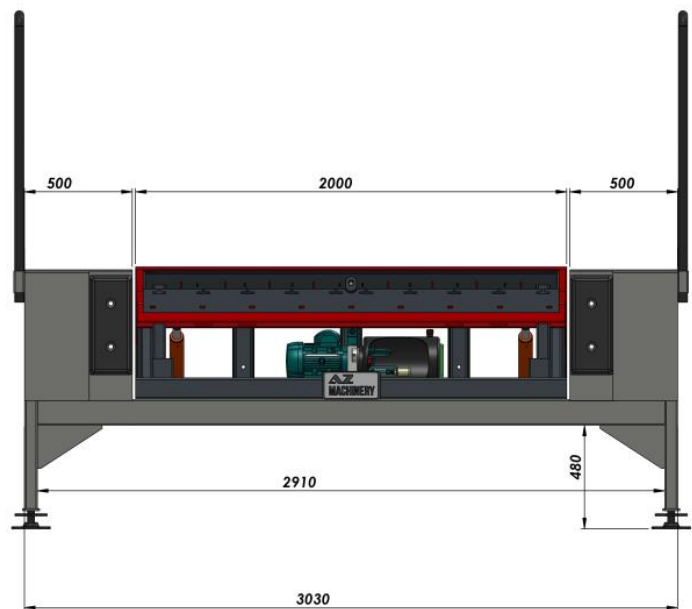
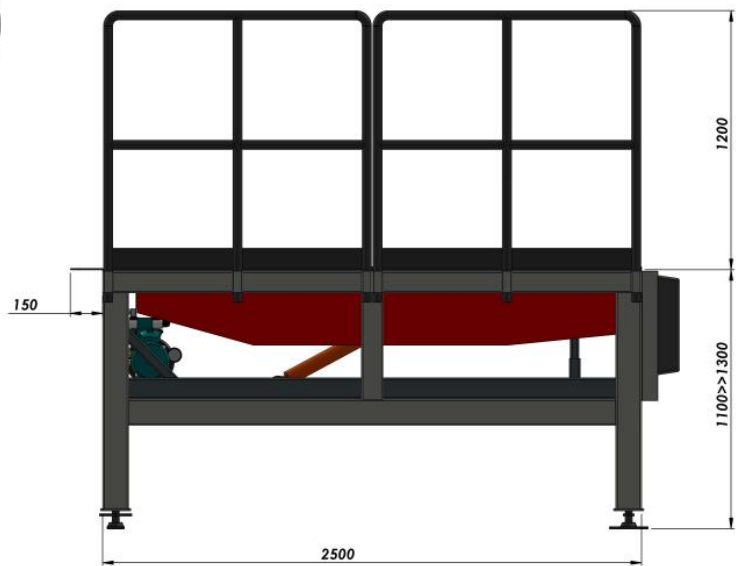

FLOOR IS DROP PATTERN SHEET

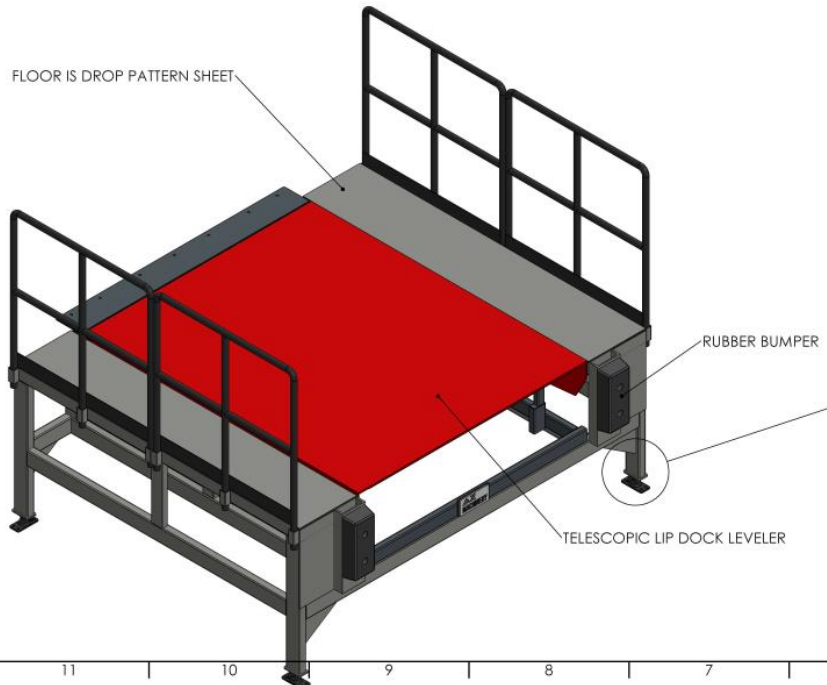

RUBBER BUMPER

TELESCOPIC LIP DOCK LEVELER



ADJUSTABLE LEG +200 MM

TELESCOPIC LIP DOCK LEVELER FEATURES

- 1- CE Certificate
- 2- Compatible design with EN 1398 and ANSI MH30.2
- 3- Working range +360/ -360 mm
- 4- Platform floor made of teardrop pattern plates
- 5- Flap is made of strengthened teardrop pattern plates
- 6- Heavy load capacity hinge system for maximum resistance to moving load
- 7- Side protection plates conforming to safety standards
- 8- Maximum operating slope 12.5% (7°) for work and worker safety
- 9- Platform floor is lifted with double hydraulic piston for high safety
- 10- Hydraulic emergency declaration mechanism
- 11- Electro-hydraulic system with IP65 protection class control panel
- 12- Security lock for maintenance
- 12- 450x200x100 mm dimensions and 70 Shore side bumpers

NAME - SURNAME	DATE	SIGN	QUANTITY	MASS (KG)	MATERIAL	PAGE NR
DRAWN BY: H. CANSEVER	25.08.2022		---			1/2
CONTROL: A. HEPBILDI	25.08.2022					
APPROVAL: S. ENTZMANN	25.08.2022					
SCALE: 1:50						
PARTASSEMBLY NAME	DRAWING DESCRIPTION:		DRAWING NO.			
	#YS84		---			



AZ MACHINERY - SLU, Matériels d'Élévation et Maintenance
 13 rue de la source - 46340 PALLATI DE CHERBOURG - France
 Téléphone : +33 (0) 27 48 300 - contact@az-machinery.com - www.az-machinery.com
 Site : 424 654 958 666 19 - TVA : FR02 824 654 958 - N° EORI : FR02 824 654 958



DRAWINGS

Rampes mobiles

Rampes fixes

Plateformes logistiques

Rampes de quai

Réhausse

Tables de quai mobiles

Tables de quai fixes

Passerelles

Rampes pour conteneurs

Niveleurs

Fournitures de quai

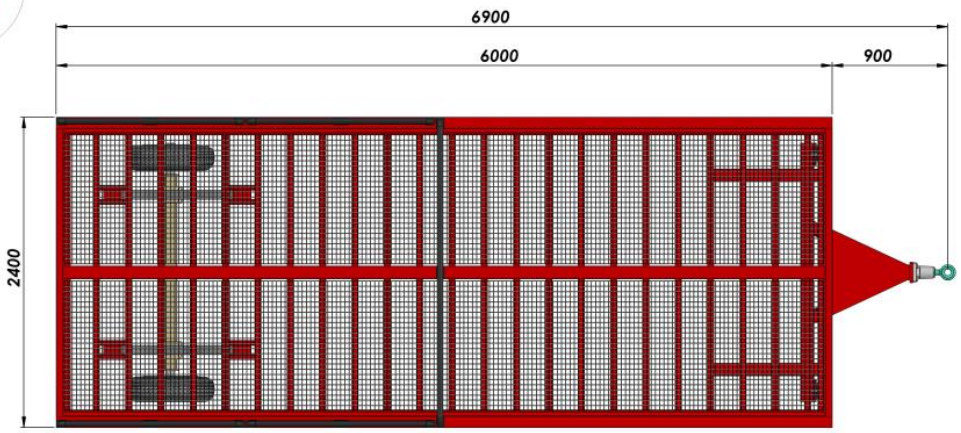
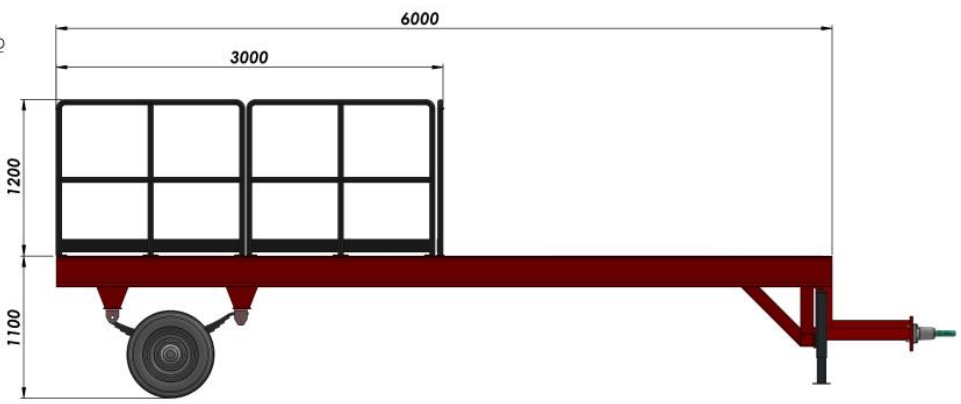
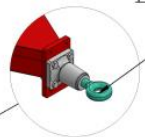
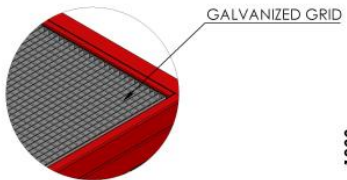
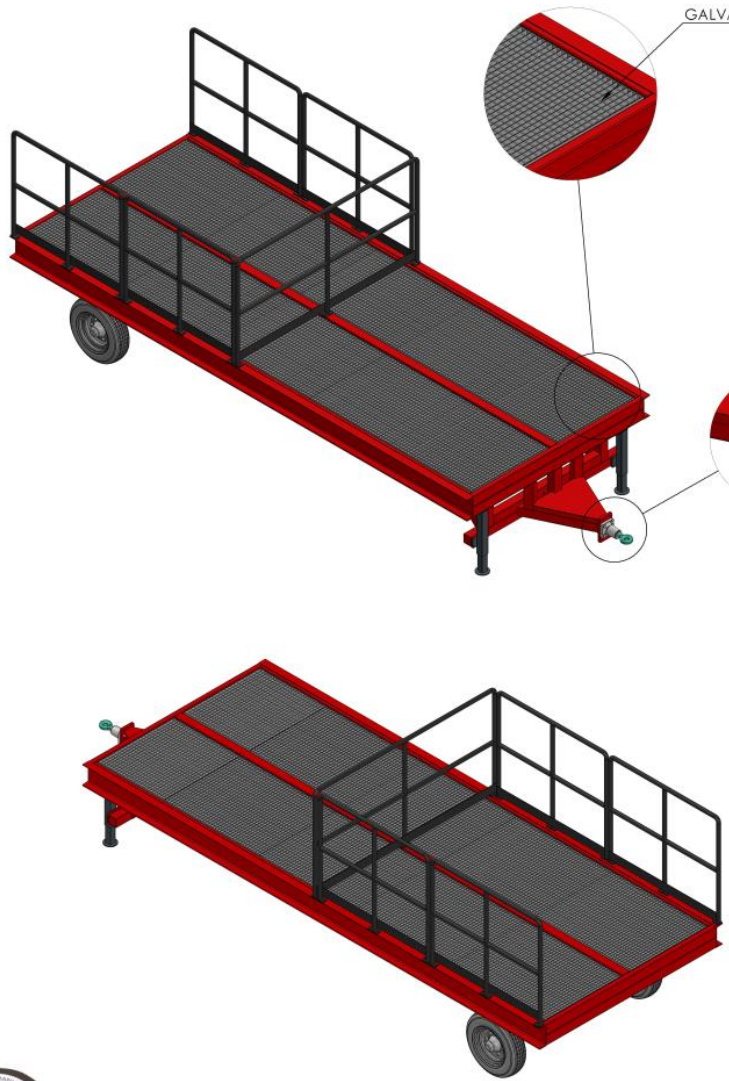

NAME - SURNAME	DATE	SIGN	QUANTITY	MASS (KG)	MATERIAL	PAGE NR
DRAWN BY: H. CANSEVER	09 01 2022		---			1/1
CONTROL: A. HEPBILDI	09 01 2022					
APPROVAL: S. ENTZMANN	09 01 2022					
SCALE: 1:50						
PART/ASSEMBLY NAME	DRAWING DESCRIPTION:		DRAWING NO.			
	#TA83		---			



AZ MACHINERY - SLU, Matériels d'Élévation et Maintenance
 13 rue de la source - 46 540 POUILLY DE CEZERNON - France
 Téléphone : +33 (0) 27 48 500 - contact@az-machinery.com - www.az-machinery.com
 Site : 424 654 958 000 FR - TVA : FR02 824 654 958 - 3^e EORL - REA02 824 654 958

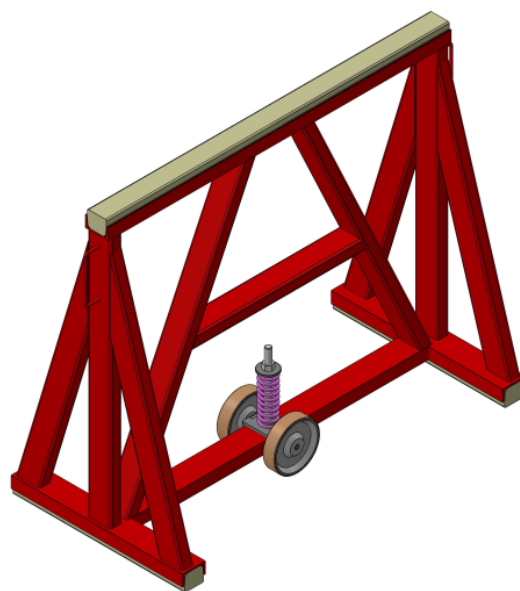
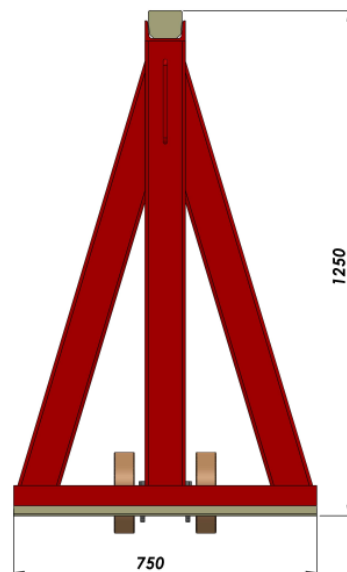
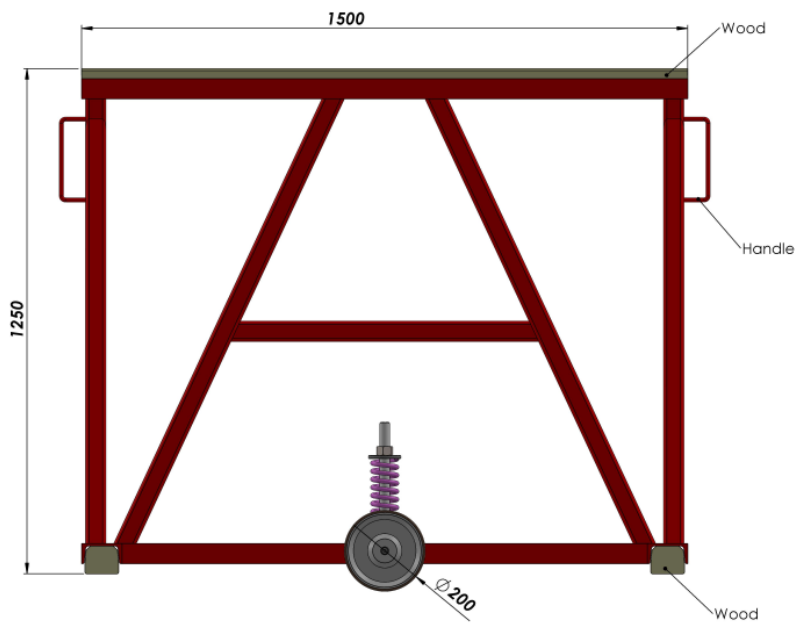

NAME-SURNAME	DATE	SIGN	QUANTITY	MASS (KG)	MATERIAL	PAGE/NB
DRAWN BY: H. CANSEVER	16.03.2023		---	130		1/1
CONTROL: A. HEPBILDI	16.03.2023					
APPROVAL: S. ENTZMANN	16.03.2023					
SCALE: 1:10						
PART/ASSEMBLY NAME			DRAWING DESCRIPTION		DRAWING NO.	



AZ MACHINERY - SLU, Matériels d'Élévation et Manutention
 13 rue de la scierie - 46 540 PULVILLAC DE CÉREACONS - France
 Téléphone : +33 (0) 37 48 300 - contact@az-machinery.com - www.az-machinery.com
 Site : 824 654 958 000 FR - TVA : FR02 824 654 958 - N° EORI : FR02 824 654 958

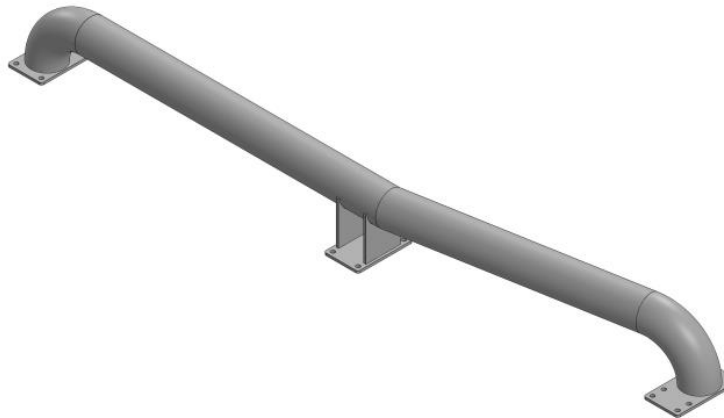
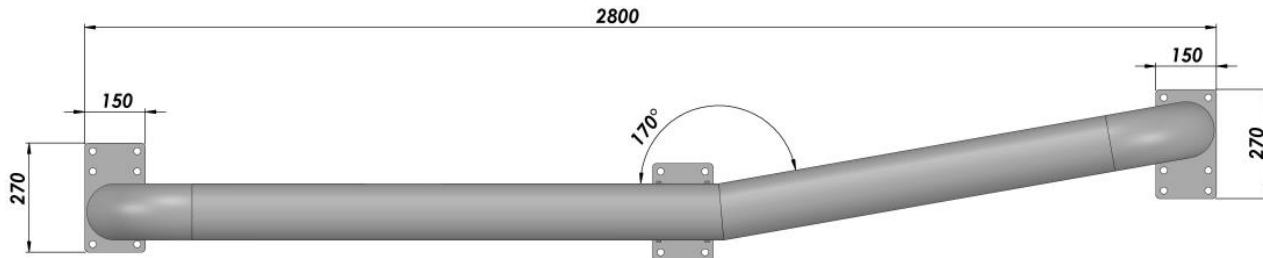
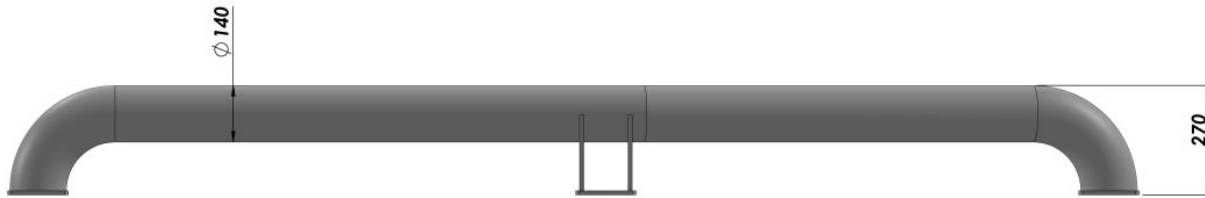

NAME - SURNAME	DATE	SIGN	QUANTITY	MASS (KG)	MATERIAL	PAGE/NT
DRAWN BY: H. CANSEVER	18.01.2022		---			1/1
CONTROL: A. HEPBILDI	18.01.2022					
APPROVAL: S. ENTZMANN	18.01.2022					
SCALE: 1:20						
PART/ASSEMBLY NAME			DRAWING DESCRIPTION		DRAWING NO.	



AZ MACHINERY - SLU, Matériels d'Élévation et Manutention
 13 rue de la Halle - 16 540 PALLAS DE CÉBERNORD - France
 Téléphone : +33 (0) 37 48 500 - contact@az-machinery.com - www.az-machinery.com
 Site : 824 654 958 000 FR - TVA : FR02 824 654 958 - N° EORI : FR02 824 654 958

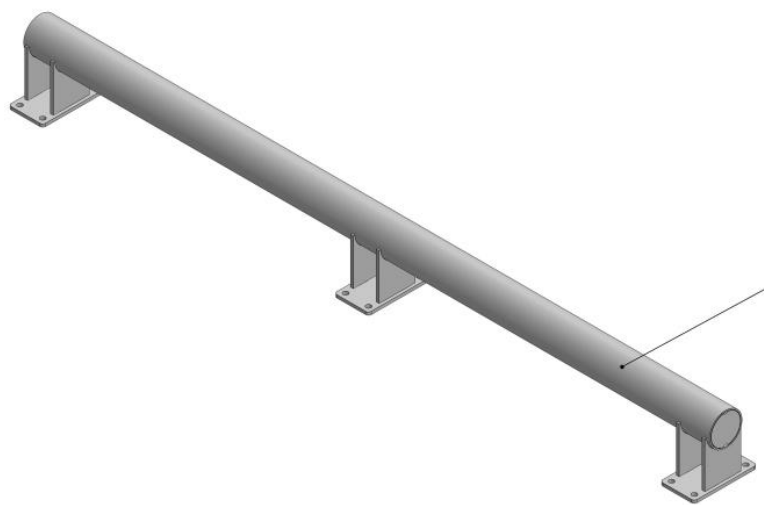
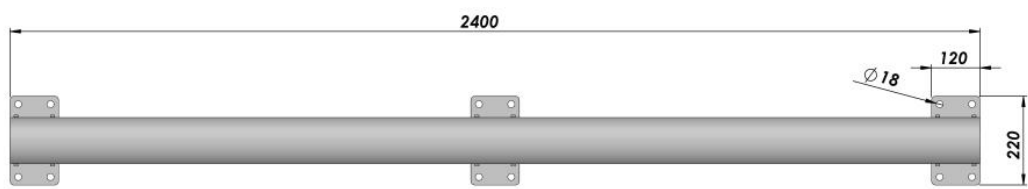
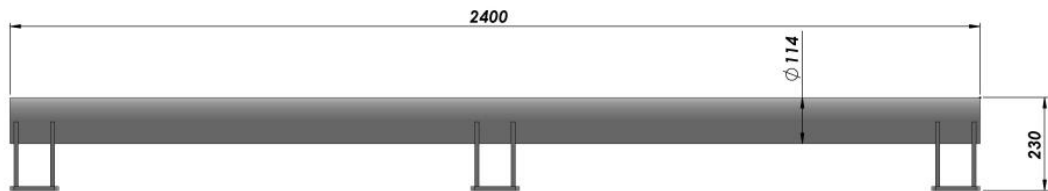

ALL SURFACES ARE HOT DEEP GALVANIZED

NAME - SURNAME	DATE	SIGN	QUANTITY	MASS (KG)	MATERIAL	PAGE/NT
DRAWN BY: H. CANSEVER	18.01.2022		---			1/1
CONTROL: A. HEPBILDI	18.01.2022					
APPROVAL: S. ENTZMANN	18.01.2022					
SCALE: 1:10						
PART/ASSEMBLY NAME			DRAWING DESCRIPTION		DRAWING NO.	



AZ MACHINERY - SLU, Matériels d'Élévation et Maintenance
 13 rue de la scierie - 16 540 PALLATI DE CEZEMANS - France
 Téléphone : +33 (0) 37 48 500 - contact@az-machinery.com - www.az-machinery.com
 Site : 824 654 958 000 FR - TVA : FR02 824 654 958 - 3° EOR01 - FR02 824 654 958

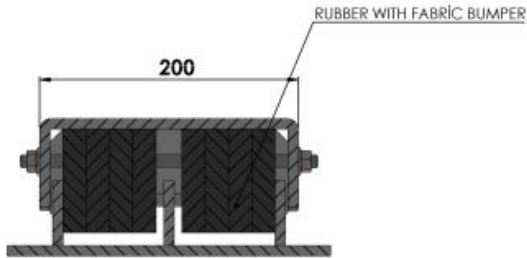
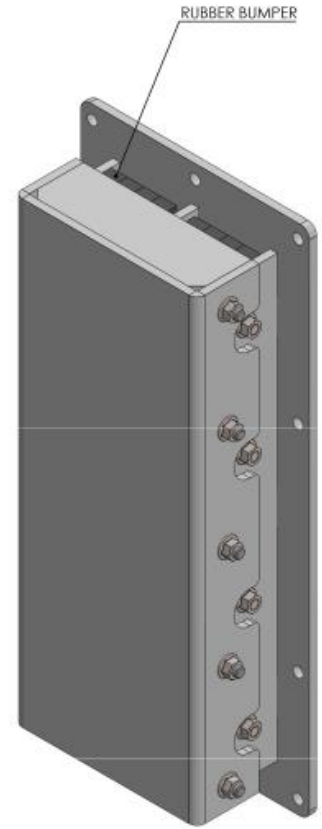
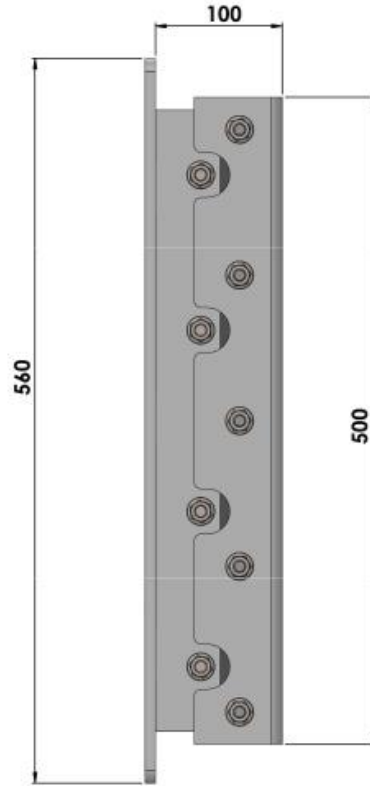
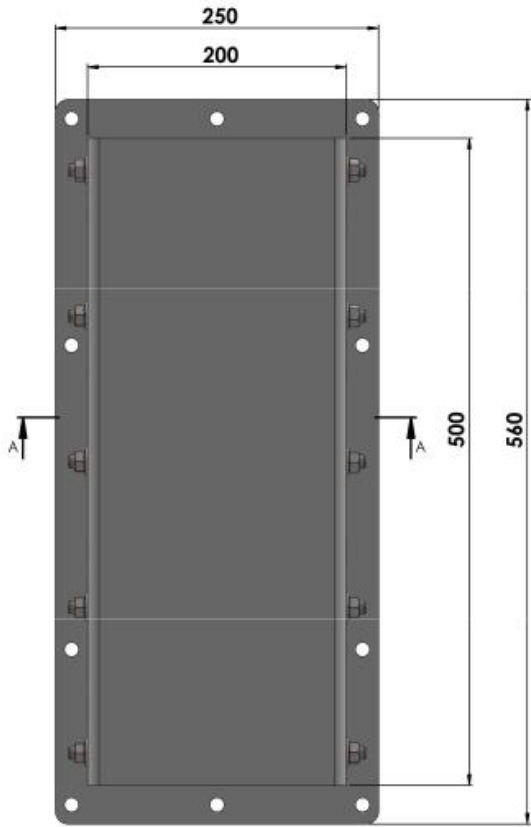

SECTION A-A
SCALE 1 : 2.5

NOTE: ALL STEEL PARTS ARE GALVANIZED

SYMBOL	NAME / SURNAME	DATE	ISSN	QUANTITY	MARKS NO.	MATERIAL	PROG. NO.
DR	H. CARBEVER	05.11.2021		---			1/1
CO	A. HEPBLDI	05.11.2021					
AP	S. ENTZMANN	05.11.2021					
SC	T.S.						
PARTS/ASSEMBLY NAME		DRAWING DESCRIPTION		DRAWING NO.			
				---		100	



AZ MACHINERY - S.R.L. Materials of Education of Manufacturing
 17 rue de la source - 46100 PALLAS (FRANCE)
 Téléphone : +33 (0) 57 27 82 801 - contact@azmachinery.com - www.azmachinery.com
 Fax : +33 (0) 57 27 82 802 - 17, rue de la source - 46100 PALLAS - FRANCE

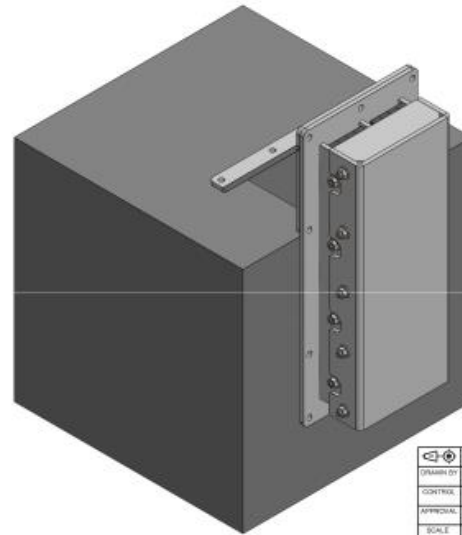
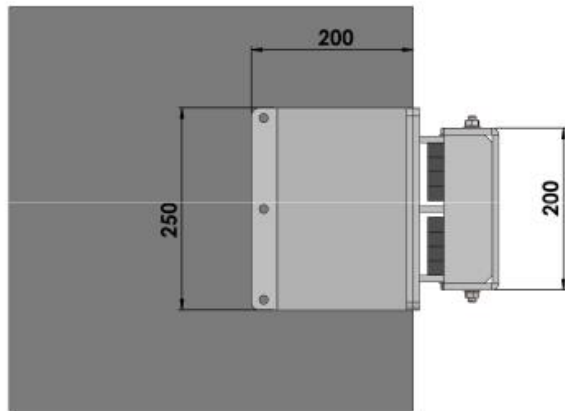
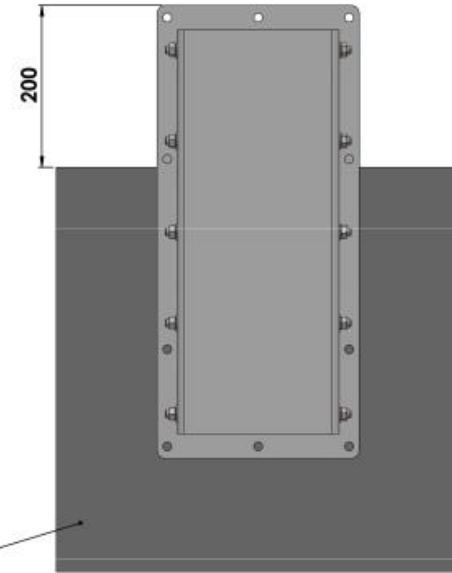
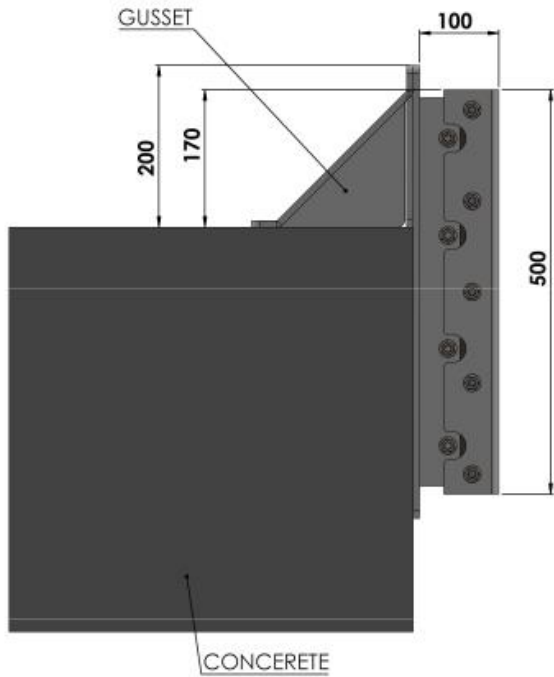

DRAMA 01	NAME / SURNAME	DATE	ISSN	QUANTITY	BARIS NO.	MATERIAL	PROJE NO.
	H. CARBEVER	05.11.2021		---			1/1
CONTROL	A. HEPBLDI	05.11.2021					
APPROVAL	S. ENZTMANN	05.11.2021					
SCALE	1:10						
PARTS/ASSEMBLY NAME		DRAWING DESCRIPTION		DRAWING NO.			



AZ MACHINERY - S.L. Materials of Education of Manufacturing
 17 rue de la source - 46140 PALLAT (46730) FRANCE
 Téléphone : 03 25 27 46 00 - contact@azmachinery.com - www.azmachinery.com
 Fax : 03 25 27 46 01 - 17, rue de la source - 46140 PALLAT - FRANCE

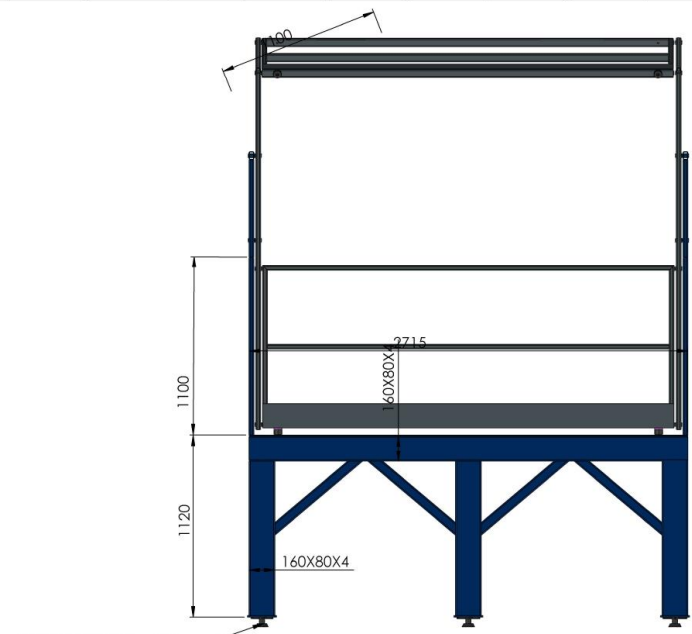
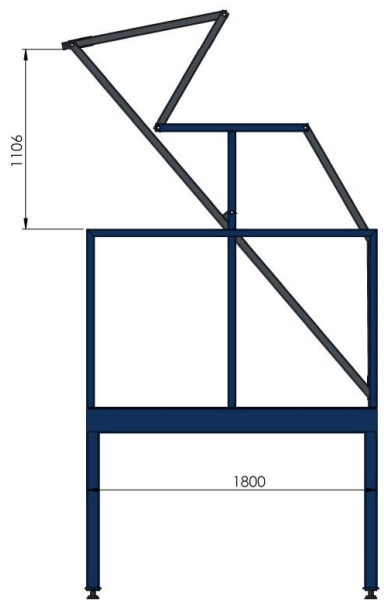

ADJUSTABLE LEG +150



ALL SURFACE IS 4/5 DROP PATTERN SHHT

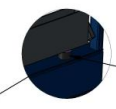
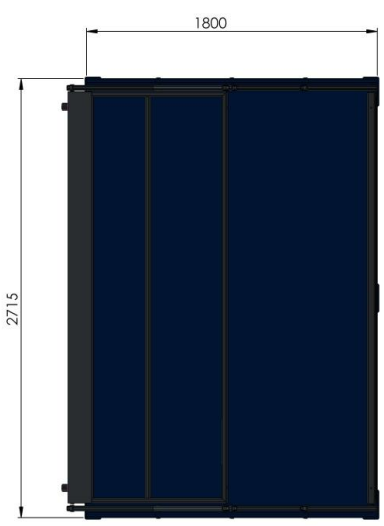

BUMPER

DETAIL B
SCALE 2 : 25

NAME-SURNAME	DATE	SIGN	QUANTITY	MASS (KG)	MATERIAL	PAGE NR
DRAWN BY N.HATIPOGLU	---	---	---			1/1
CONTROL H.CANSEVER	---	---				
APPROVAL K.TEKIN	---	---				
SCALE 1:50						
PARTASSEMBLY NAME		DRAWING DESCRIPTION		DRAWING NO		
		FRA-ORD-42 LAYOUT		---		



AZ MACHINERY - SLU, Matériels d'Élévation et Maintenance
 13 rue de la scierie - 06340 PALAISEAU DE CERDAGNE - France
 Téléphone : +33 (0) 27 48 500 - contact@az-machinery.com - www.az-machinery.com
 Site : 024 654 958 000 10 - TVA : FR02 824 654 958 - N° EORI : FRAD 824 654 958



AZ MACHINERY

13 rue de la scierie
66340 PALAU DE CERDAGNE
France

Siret : 824 654 958 000 19
TVA : FR62 824 654 958
N° EORI: FRAD 824 654 958

Siège social :
Carrer Doctor Palau N°8
AD600 Sant Julià de Loria
Andorre

NRT : L-711694-Z
N° Registral : 16585

service.commercial@az-machinery.fr

www.az-machinery.com

